

## Operating instructions

VEGACOM 557

VEGA ASCII protocol

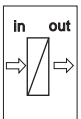
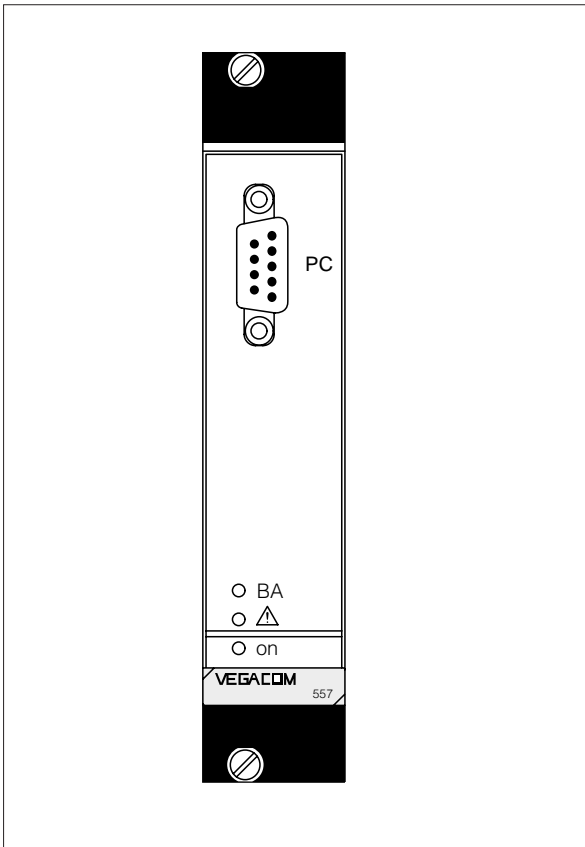

**Contents**

Safety information .....	2
Note Ex area .....	2

**1 Product description**

1.1 Application .....	4
1.2 Configuration .....	4
1.3 Functions .....	5
1.4 Type plate .....	9
1.5 Technical data .....	10
1.6 Dimensions .....	12
1.7 Indicating and adjustment elements .....	13

**2 Mounting and electrical connection**

2.1 Mounting instructions .....	14
2.2 Mounting in carrier and housing .....	15
2.3 Wiring plan VEGACOM 557 .....	15
2.4 Mounting and installation instructions with VEGACOM 557AP .....	17

**Safety information**

Please read this manual carefully, and also take note of country-specific installation standards (e.g. the VDE regulations in Germany) as well as all prevailing safety regulations and accident prevention rules.

For safety and warranty reasons, any internal work on the instruments, apart from that involved in normal installation and electrical connection, must be carried out only by qualified VEGA personnel.

**Note Ex area**

Please note the approval documents (yellow binder), and especially the included safety data sheet.

<b>3</b>	<b>Switch settings on VEGACOM 557</b>	
3.1	Adjustment of the PC interface .....	20
3.2	Adjustment of the VEGA ASCII interface .....	21
<b>4</b>	<b>Data image in VEGACOM 557</b>	
4.1	Enquiry for VEGAMET with three or less values per instrument .....	26
4.2	Enquiry for VEGAMET with up to seven values per instrument .....	28
4.3	Enquiry as block with low resolution .....	30
4.4	Enquiry as single value with low resolution .....	32
4.5	Enquiry as range with low resolution .....	34
4.6	Enquiry as block with address and low resolution .....	36
4.7	Enquiry as single value with address and low resolution .....	38
4.8	Enquiry as range with address and low resolution .....	40
4.9	Enquiry for the contact inputs and outputs on DISBUS .....	42
4.10	Enquiry for the contact inputs and outputs on LOGBUS .....	43
4.11	Enquiry for the software version .....	44
4.12	Error information from VEGACOM 557 .....	44
4.13	Parameter adjustment of VEGALOG or VEGAMET via VEGA ASCII .....	45
<b>5</b>	<b>Setup</b>	
5.1	Setup check list: .....	46
5.2	Communication structure .....	46
5.3	Setup example for the PC .....	47
5.4	Example program for the enquiry VEGAMET (QUICK BASIC) .....	49
5.5	Example program for the enquiry VEGALOG (VISUAL BASIC 4.0) .....	53
	<b>Supplement A .....</b>	<b>56</b>

# 1 Product description

## 1.1 Application

The VEGACOM 557 is an efficient and easy-to-use interface converter (Gateway) for your measurement applications. It is used for conversion of the VEGA-specific protocols of DISBUS and LOGBUS into standard data formats.

The existing version is used for connection of level or pressure measuring systems to Profibus DP systems such as

- processing systems (DCS)
- personal computers (PC)
- stored program control (PLC).

In addition, it is used for connecting a PC for configuration or visualisation via the VEGA adjustment software.

If connection is made to external systems, there is the possibility of calling up measurement data and status information of the measuring systems via the master of the external system. The coupling of the external system is made via the connections on the rear of the instrument. This data traffic requires that special measures (described in this manual) be taken in setting up the master of the external system. The data received in the master can be visualised there or further processed for control purposes. In restricted volume, signal conditioning instrument-specific parameters can be outputted, modified and returned again.

Via the PC interface on the front of VEGACOM 557, the VEGA visualisation software "Visual VEGA" or the VEGA configuration software "VEGA Visual Operating" (VVO) can be operated. For these applications, the coupling between VEGACOM 557 and a PC is made directly with the connection cable between the RS 232 interface (PC) on the front of VEGACOM 557 and a standard Port (e.g. COM1) of your PC. There is also the possibility to provide a connection via modems.

## 1.2 Configuration

The component VEGACOM 557 is designed in 19" technology with 5 TE width (1 TE = 5.08 mm) acc. to DIN 41 494. It can be used:

- in carrier BGT 596
- in VEGALOG 571 carrier BGT LOG 571
- in housing type 505.

The electrical connection of supply voltage, DISBUS and Modbus is made via a plug connection acc. to DIN 41 612 on the rear of the component. The connection to LOGBUS is made via an additional 5-pole plug-connector mounted to the DIN-socket.

A 9-pole SUB-D plug marked "PC" is located on the front panel of VEGACOM 557. It is used for connection of a PC via RS 232C to VEGACOM 557.

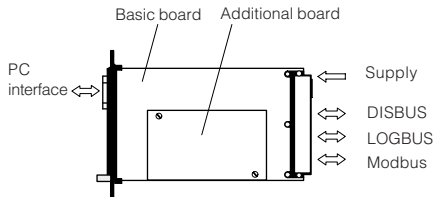

*VEGACOM 557 connections*

The component consists of two boards:

- the basic board
- the additional board.

On the basic board, you will find the power supply unit, the PC interface, the DISBUS/ LOGBUS interface as well as the connections for the VEGA ASCII interface.

The additional board is screwed to the basic board and includes the hardware of the VEGA ASCII interface as well as the protocol specific programs.

### 1.3 Functions

The VEGACOM 557 interface converter can be integrated into the VEGA level or pressure measuring system in two different ways:

either

- as DISBUS participant
- or
- as LOGBUS participant.

In both cases, VEGACOM 557 operates as passive participant and provides measured data and status information of the connected VEGA signal conditioning instruments via the external system. Through the use of readable text, a connection with simple terminal programs is possible.

Alternatively, it is possible to connect a PC with VEGA adjustment software via the SUB-D-plug marked "PC" on the front panel of VEGACOM 557. VEGA adjustment software is actually available as two different Windows applications.

VVO = VEGA Visual Operating

For configuration and parameter adjustment of the connected VEGAMET or VEGALOG processing systems

VV = Visual VEGA

For visualising and recording of measured values of complete (multiple) vessel installations.

The following pictures show the basic connection possibilities of VEGACOM 557.

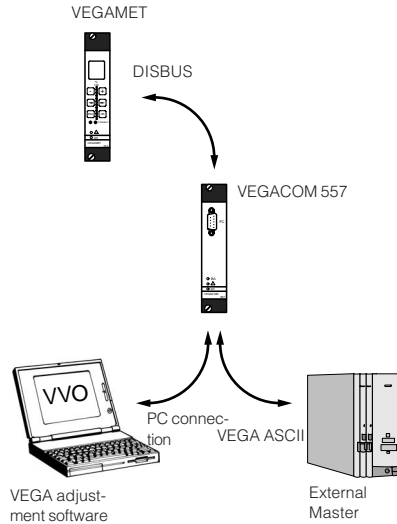

*VEGACOM 557 as DISBUS participants*

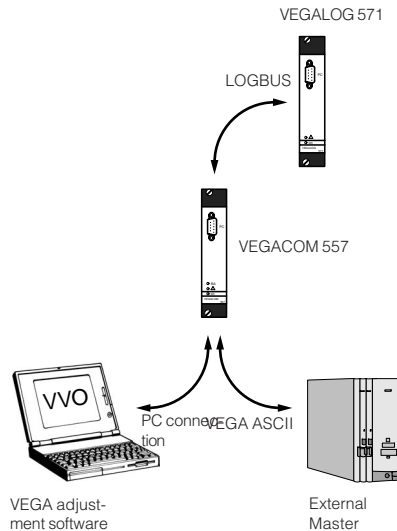

*VEGACOM 557 as LOGBUS participant*

**VEGACOM 557 on DISBUS**

VEGAMET series 500/600 signal conditioning instruments transmit via the DISBUS cyclically measured data and status information, so called PC/DCS telegrams. VEGACOM 557 receives these data as participant on the DISBUS and makes them available (in buffer memory) for collection via the VEGA ASCII protocol.

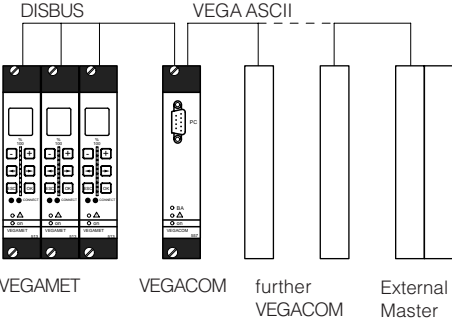

Connection VEGACOM 557 to DISBUS

If a PC is connected to the PC interface (front interface) of VEGACOM 557, this instrument transfers acyclically (on request by the VEGA configuration software VVO) measurement loop parameters from or to VEGAMET.

Max. two VEGACOM 557 can be connected to the same DISBUS. For clear identification, a different instrument address should be assigned to each instrument.

**VEGACOM 557 on LOGBUS**

Data are exchanged continuously on the LOGBUS between the individual components of VEGALOG 571. VEGACOM 557 receives as participant of this LOGBUS PC/DCS telegrams including the measured values and status information and makes them available (in buffer memory) for collection via the VEGA ASCII protocol.

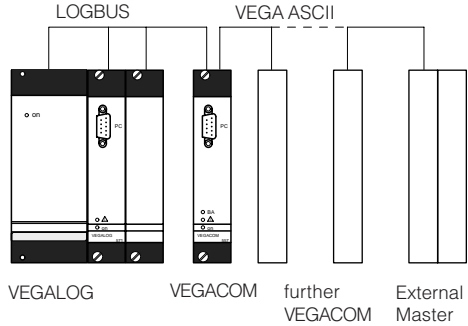

Connection VEGACOM 557 to LOGBUS

If a PC is connected to the PC interface (front interface) of VEGACOM 557, this instrument transfers acyclically (on request by the VEGA configuration software VVO) measurement loop parameters from or to VEGALOG 571.

Max. two VEGACOM 557 can be connected to the same LOGBUS. The addressing for clear identification is made automatically on LOGBUS.

### VEGACOM 557 with VEGA ASCII

The data communication between VEGACOM 557 and a master is only carried out if initiated by the master, which can enquire the requested information by means of special commands.

The data from DISBUS/LOGBUS are first written in a buffer memory of VEGACOM 557. The data set is transferred from this buffer memory into a process image. The protocol conversion software enquires the stored data cyclically from the individual storage areas.

The data sets are checked and converted into the VEGA ASCII data format. After the conversion, the data are transferred into the emission memory and are sent from there to the master.

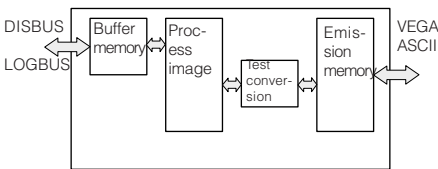

Function VEGACOM 557

### VEGACOM 557 with VVO or VV

#### Direct connection

As an alternative to the VEGA ASCII communication, a PC can be connected via the PC interface (SUB-D-plug in the front panel of VEGACOM 557). By means of the adjustment and indicating software VEGA Visual Operating (VVO), the parameter adjustment can be made on the signal conditioning instruments

connected to VEGACOM 557. The adjustment concept includes the user-friendly configuration and parameter adjustment of the measuring system or the sensor with the following instruments:

- VEGAMET series 500/600 signal conditioning instruments
- VEGALOG 571 processing system
- VBUS ultrasonic/radar sensors.

The adjustment is menu-driven and window orientated. No matter if a radar sensor, several connected signal conditioning instruments or a VEGALOG should be adjusted via the PC, the procedure is always the same. As another possibility, measured values and fault signals of the entire processing facility can be recorded and shown graphically by means of the visualisation software VISUAL VEGA (VV). Tools for processing and analysis of history data are also available.

The configuration of the measurement loop comprises, depending on the connected instruments, e.g. the determination of output functions or the configuration of individual outputs or inputs. The user-orientated editing of measurement loops is supported by graphic means, such as e.g. vessel drawings and pictographs that adapt to the selected general conditions and options. Thanks to the graphical support, even more complex parameter adjustments such as e.g. the input of a linearisation curve by means of index markers can be done with ease.

#### Connection via modem

The PC interface supports, beside the direct connection of a PC, also the operation via modems. With this additional function, remote parameter adjustment or remote diagnostics of VEGA systems via VVO are possible. Together with the visualisation software Visual VEGA, even remote visualisations can be carried out.

**Complete measuring system with digital communication and networking**

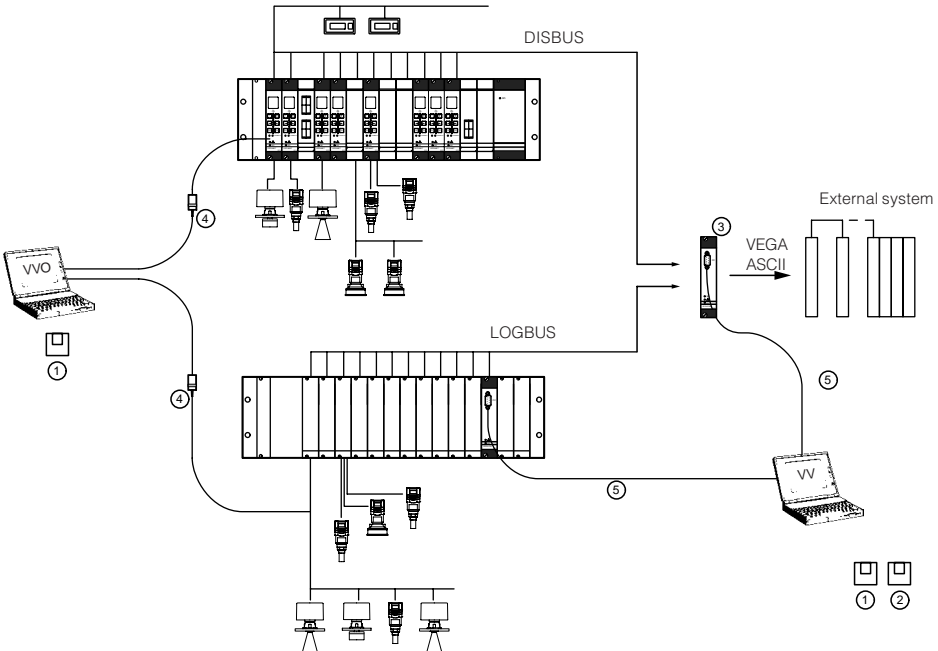

*Measuring system with digital communication and networking*

**Explanation:**

- 1 VEGA Visual Operating (VVO)  
Adjustment software for the PC for the user-friendly configuration and parameter adjustment of VEGA instruments
  - VEGALOG 571 directly via RS 232 connection cable on the CPU card or VEGACOM 557
  - several VEGAMET via VEGACOM 557 or individually via VEGACONNECT
  - VEGASON, VEGAPULS via VEGACONNECT on the signal line or on the sensor
- 2 Visual VEGA (VV)  
PC visualisation software for presentation of measurement data from VEGA instruments in a graphical or tabular form. Integration of individual measurement loops into groups, saving of fault signals and measured values (recorder function). Suitable for networks

- 3 VEGACOM 557  
Interface converter for conversion of VEGA specific protocols into standard data formats. Suitable for connection to the DISBUS output of VEGAMET series 500/600 signal conditioning instruments or the LOGBUS of VEGALOG 571 processing system.
- 4 VEGACONNECT 2  
Connection cable (interface converter) between VEGA instruments (VEGASON, VEGAPULS or VEGAMET) and a PC in conjunction with the adjustment software VEGA Visual Operating.
- 5 RS 232 connection cable (interlink cable)  
Connection cable between PC and VEGALOG 571-CPU or VEGACOM 557

## 1.4 Type plate

### Type plate

Before mounting and electrical connection, please check if you are using the correct version of VEGACOM 557. Please note the type plate, located below the multiple plug.

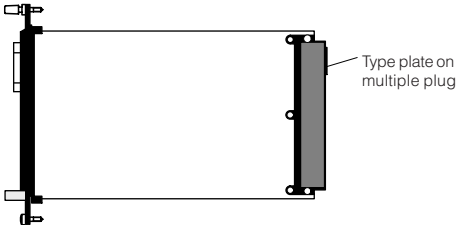

The type plate contains important data required for electrical connection. The configuration and the components of the type plate are explained in the illustration below.

**Note:**

The serial number of your VEGACOM is on the rear of the plug connector.

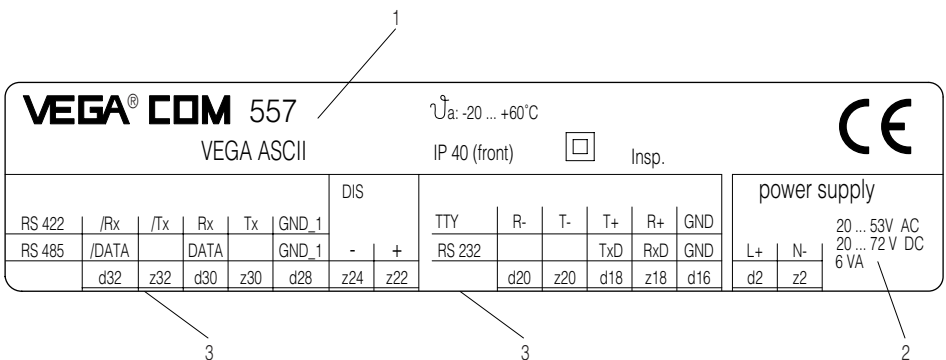

- 1 Version: VEGA ASCII
- 2 Supply voltage
- 3 Terminal assignment of the possible interface to VEGA ASCII

## 1.5 Technical data

### Power supply

Supply voltage	$U_{nom} = 24 \text{ V AC (20 ... 53 V), 50/60 Hz}$ or $= 24 \text{ V DC (20 ... 72 V)}$
Power consumption	approx. 6 VA
Fuse	1 A, slow-blow

### Electrical connection

Component	multiple plug acc. to DIN 41 612, series F 48 pole (d, b, z) with coding holes
Module in carrier BGT 596 or BGT LOG 571	suitable multipoint connector acc. to DIN 41 612 with connection via standard technologies
Housing type 505	via screw terminals max. $1 \times 1.5 \text{ mm}^2$

### Indicating elements

LED on front panel	green "BA": VEGA ASCII active red: failure, freeze mode green "on": operating mode
--------------------	--

### Meas. data input DISBUS

Data transmission	DISBUS (digital data transmission)
Connection cable	2-wire standard cable (shielded)
Cable length	max. 1000 m

### Measuring data input LOGBUS

Data transmission	LOGBUS (digital data transmission)
Connection cable	connection via BUS-plug

### PC interface

Interface standard	RS 232C
Cable length	max. 15 m
Transmission rate in baud	300, 600, 1200, 2400, 4800, <b>9600</b> , 19200, 38400
Transmission format	8 data bits, 1 stop bit, no parity or even parity
Plug on front panel	SUB-D-plug connector, 9 pole, pins

### Modbus interfaces

Interfaces	RS 232	RS 422	RS 485	TTY
Cable length	15 m	1200 m	1200 m	1000 m
Connection cable	3-wire	5-wire	3-wire	4-wire
	twisted in pairs, shielded			
Transmission mode	serially asynchronous, half-duplex			
Transmission rate	300; 600; 1200; 2400; 4800; 9600; 19200; 38400 baud			
Galvanic separation	up to 0.5 kV			

**Modbus ASCII-mode**

Coding system	hexadecimal, ASCII-character
Number of bits	1 start bit, 7 or 8 data bits, 1 (0) parity bit, 1 stop bit
Parity	NONE, ODD, EVEN
Backup	none

**Electrical protective measures**

Protection:	
not mounted	IP 00
in carrier BGT 596 or BGT LOG 571	
- front side completely equipped	IP 40
- upper and lower side	
BGT 596	IP 00
BGT LOG 571	IP 20
- wiring side	IP 00
in housing type 505	
- front side	IP 40
- other sides	IP 30
Protection class	II (in housing type 505)
Overvoltage category	II

**Electrical separation measures**

Reliable separation acc. to VDE 0106, part 1 between power supply, LOGBUS, DISBUS, PC-connection and respective interface	
- reference voltage	250 V
- test voltage	2 kV

**Ambient conditions**

Permissible ambient temperature	-20°C ... +60°C
Storage and transport temperature	-20°C ... +85°C
Humidity	93 %, T = 40°C acc. to DIN/IEC 68-2-3
Shock	2 ... 100 Hz, 0.7 g

**Mechanical data**

Series	module unit for
	- carrier BGT 596
	- carrier BGT LOG 571
	- housing type 505
Dimensions, not mounted	W = 25.4 mm (5 TE), H = 128.4 mm, D = 166 mm
Weight	approx. 550 g

**CE conformity** 

VEGACOM 557 meets the protective regulations of EMC (89/336/EWG) and NSR (73/23/EWG). The conformity has been judged acc. to the following standards:

EMC Emission	EN 50 081 - 2: 1993
Susceptibility	EN 50 082 - 2: 1995
NSR	EN 61 010 - 1: 1993

**1.6 Dimensions**

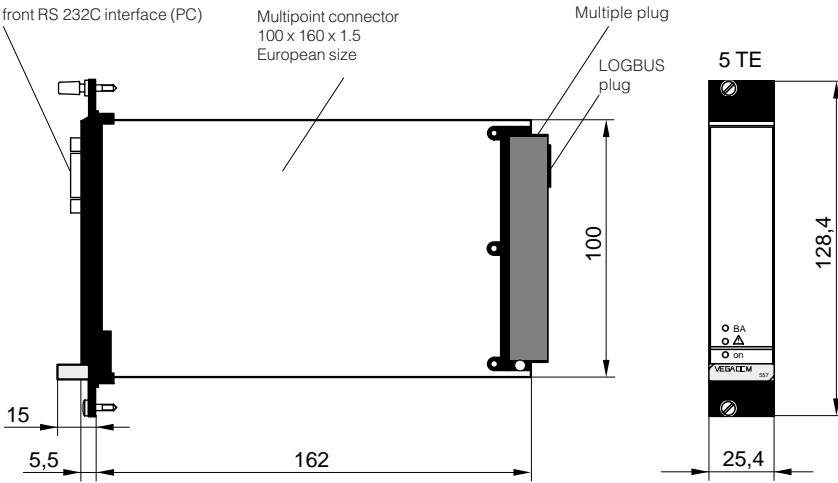

## 1.7 Indicating and adjustment elements

As diagnostic aid, VEGACOM 557 is equipped with three LEDs. These are located on the instrument front panel. In addition, the basic board, as well as the additional board of VEGACOM 557 are equipped with a number of switches (DIP switch or hook switch) for configuration of the available interfaces.

### Indicating elements/Diagnostics LEDs

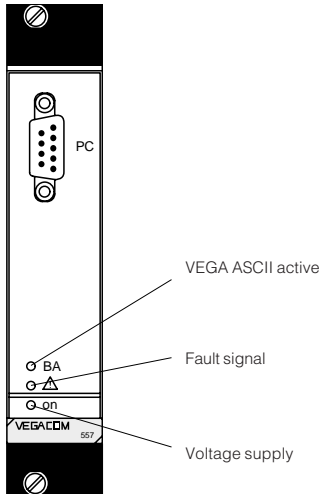

Front of VEGACOM 557

Meaning of the LEDs:

VEGA ASCII active:

- green LED lights in case of valid data exchange

Fault signal:

- red LED flashing: DISBUS/LOGBUS-error
- irregularly flashing: no PC/DCS outputs assigned
- permanent light: hardware error or special function "Freeze Mode"

Voltage supply:

- green LED lights, operating voltage on.

### Adjustment elements

The adjustment elements are located on the basic board. A 6-pole DIL-switch block on the basic board is used for adjustment of the front PC interface.

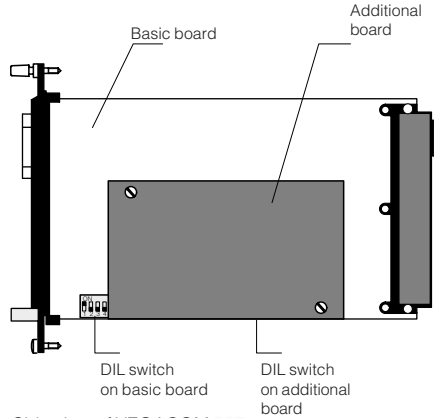

Side view of VEGACOM 557

### Special function "Freeze Mode"

For diagnostic purposes on VEGA processing systems VEGAMET and VEGALOG, the process image can be "frozen" in VEGACOM 557 with the adjustment software VVO. This enables the possibility of carrying out maintenance work on the VEGA system, without disturbing the higher-priority processing system.

For activating the Freeze Mode, a PC must be connected directly to the PC interface of VEGACOM 557 and the Freeze Mode must be switched on under VVO in the menu "Configuration - Measuring system".

### Attention:

Before activating this function, you must make sure that during this mode no disastrous consequences are to be expected for production processes (during this mode, no level values etc. are updated).

## 2 Mounting and electrical connection

### 2.1 Mounting instructions

The gateway VEGACOM 557 can process measured data and status information in two different ways:

- via DISBUS (from measuring systems with VEGAMET)
- via LOGBUS (from measuring systems with VEGALOG).

For DISBUS configurations, VEGACOM 557 can be either mounted into carrier BGT 596 or housing type 505.

In conjunction with LOGBUS, VEGACOM 557 is mounted into carrier BGT LOG 571. The location is individually selectable, the system adapts automatically when rebooting (autoconfiguration).

#### Coding

A mechanical coding system prevents mixing up the different module cards in the carrier or in the housing.

The coding system consists of:

- three coded pins in the multipoint connector
- three holes in the multiple plug of VEGACOM 557.

The coded pins are attached to the module or the housing. The plug-in socket must be equipped by the user with the coded pins according to the following table and diagram.

	Instrument coding	Function coding
VEGACOM 557	a27	c3/c11

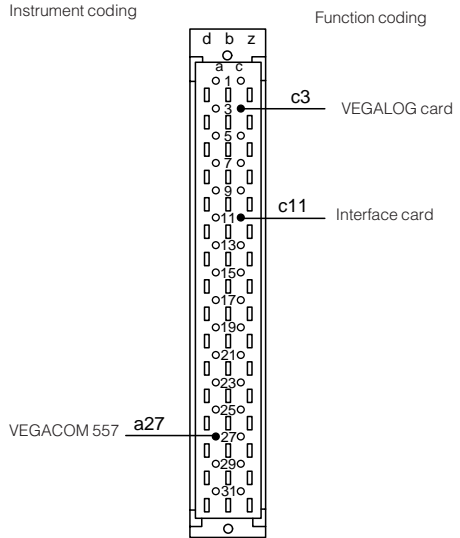

Positioning of the coded pins

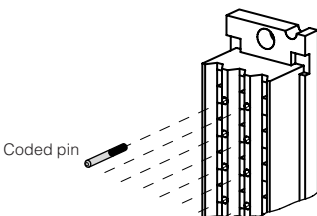

Plug-in socket of VEGACOM 557

## 2.2 Mounting in carrier and housing

### BGT 596 or BGT LOG 571

For mounting, a slot module must be provided at the location. A slot module consists of:

- a multipoint connector acc. to DIN 41 612, series F, 33-pole (d, b, z)
- two screws
- three coded pins
- two guide rails.

The multipoint connector is available in the following versions:

- Wire-Wrap, standard connection  
1.0 mm x 1.0 mm
- plug connection  
2.8 mm x 0.8 mm
- Termi-Point standard connection  
1.6 mm x 0.8 mm
- soldering connection
- screw terminals 0.5 mm<sup>2</sup>.

For mounting the module, please note the operating instructions of the carrier.

### Housing type 505, type 506

This housing is already equipped with a multipoint connector. Before mounting, please check if the housing is equipped with a power supply unit or not.

The connection is made via screw terminals with max. 1.5 mm<sup>2</sup>. Further details are stated in the operating instructions "Housing type 505, type 506".

## 2.3 Wiring plan VEGACOM 557

### PC interface in front panel (SUB-D-plug)

The PC interface of VEGACOM 557 is used exclusively for connection of computer systems with VEGA adjustment software via a COM-Port. The PC interface is based on the RS 232C standard and is assigned as follows.

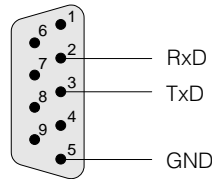

Pin assignments of the PC interface of VEGACOM 557

Pin	Description	I/O
2	RxD receive data	I
3	TxD transmit data	O
5	GND ground	-

#### Note:

With a direct connection to the computer system, VEGACOM 557 works without hardware handshake.

#### Direct connection

For direct connection of a PC to the PC interface of VEGACOM 557, the interlink (or a standard) cable available from VEGA with 9-pole plugs on both ends should be used. The pin assignments of the interlink cable are shown in the diagram.

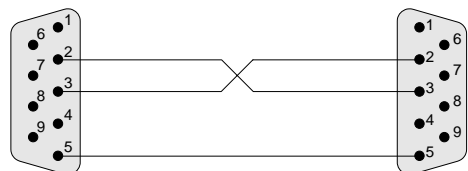

Wiring proposal for interlink cable

## Connection via modem

For remote parameter adjustment, it is possible to connect the PC interface via a modem. In such a case, the modem cable that comes with the respective modem should be used. Modem operation is supported by VEGA-COM 557 from software version 2.11. Further information on the remote parameter adjustment is stated in the operating instructions "Remote parameter adjustment".

## Connections of the multiple plug (rear)

For connection of VEGACOM 557 to the existing VEGA ASCII system all standard interfaces are available. The power supply of the instrument and the connection to the VEGA system are always the same. The following illustrations show the respective terminal assignments depending on the selected interface type.

VEGA ASCII via RS 485

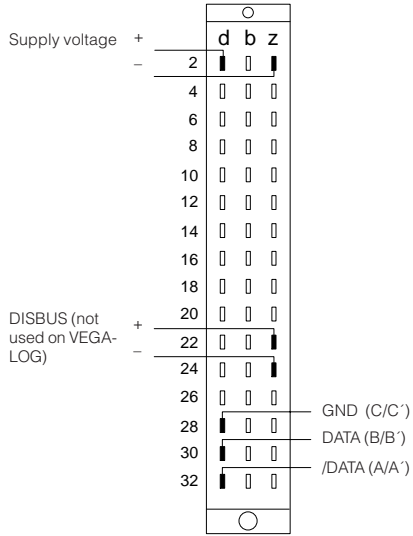

Wiring regulation for VEGA ASCII via **RS 485**

VEGA ASCII via RS 232 C

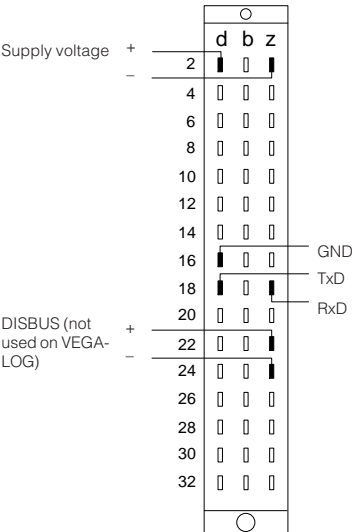

Wiring regulation for VEGA ASCII via **RS 232 C**

VEGA ASCII via RS 422

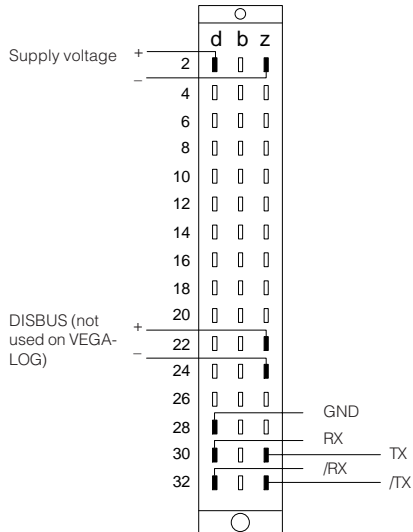

Wiring regulation for VEGA ASCII via **RS 422**

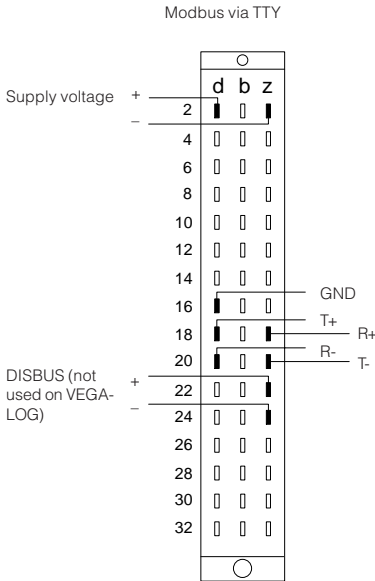

Wiring regulation for VEGA ASCII via TTY

## 2.4 Mounting and installation instructions with VEGACOM 557AP

As an option, VEGACOM 557 can be extended with the adapter print VEGACOM 557AP. The adapter print VEGACOM 557AP consists of a module card with 5 TE width and two modules connected to a back-panel print for carrier BGT 596 or BGT LOG 571.

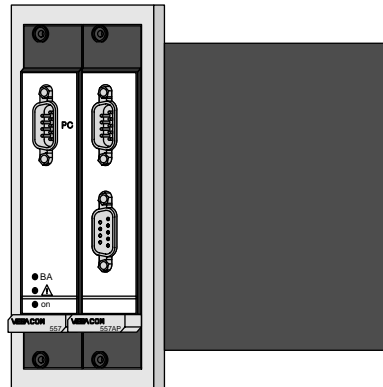

VEGACOM 557 with adapter print VEGACOM 557AP

With the adapter print card it is possible to put the interfaces of VEGACOM 557 at the front of the carrier. On the front of the adapter print card, the VEGA ASCII interface is available as a 9-pole SUB-D-plug and as 9-pole SUB-D-socket. The required interface type must be stated when ordering VEGACOM 557AP.

The following interface types are available:

- RS 232
- RS 422
- RS 485
- TTY

Make sure that also VEGACOM 557 is set to the same interface type (DIL-switch 1 on the additional board) as VEGACOM 557AP. The pin assignments of SUB-D-plug and SUB-D-socket is listed in the tables.

**Pin assignments VEGACOM 557AP**

Pin-Nr.	RS 232	RS422	RS485	TTY
1	-	-	-	-
2	RXD	RX	-	T+
3	TXD	TX	DATA	R+
4	-	-	-	-
5	GND	GND	GND	GND
6	-	-	+5V	-
7	-	/RX	-	T-
8	-	/TX	/DATA	R-
9	-	-	-	-

9-pole SUB-D-plug

Pin-Nr.	RS 232	RS422	RS485	TTY
1	-	-	-	-
2	TXD	RX	-	T+
3	RXD	TX	DATA	R+
4	-	-	-	-
5	GND	GND	GND	GND
6	-	-	+5V	-
7	-	/RX	-	T-
8	-	/TX	/DATA	R-
9	-	-	-	-

9-pole SUB-D-socket

**Mounting instructions for VEGACOM 557AP**

The two modules connected to the back-panel print consist of:

- two multipoint connectors acc. to DIN 41 612, series F, 48-pole (d, b, z) connected via the back-panel print
- four screws
- six coded pins
- four guide rails

**Coding**

The coding should be carried out for both modules as described in chapter "2.1".

**Module position**

**BGT LOG 571**

The module position is individually selectable, the VEGALOG 571 processing system adapts automatically through autoconfiguration during the first booting. After autoconfiguration, the slot location of the cards must never be changed.

**BGT 596**

The module position is individually selectable. Please note that the two connected modules cover a width of 10 TE (5 TE for VEGACOM 557 plus 5 TE for the adapter board VEGACOM 557AP).

**Connection VEGACOM 557AP**

**BGT LOG 571**

With the bus board (part of the carrier BGT LOG 571) connection to LOGBUS is made automatically when inserting VEGACOM 557.

The voltage supply of the card must be provided separately. For this reason, a 2-pole terminal with tension spring connection, called  $U_b$ , is available on the back-panel print. The permissible operating voltage of VEGACOM 557 should be observed. In case of DC voltage supply, the correct polarity should be noted!

**BGT 596**

When operating VEGACOM 557 as DISBUS participant, the DISBUS must be wired in addition to the supply voltage.

For the two cables of the DISBUS, a 2-pole terminal with tension spring connection is available. Make sure that the polarity is correct!

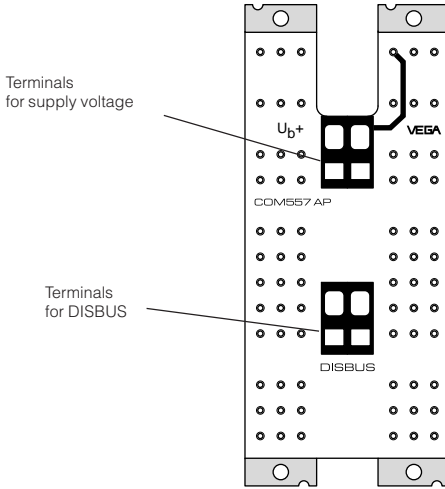

View of back-panel board (rear of the carrier)

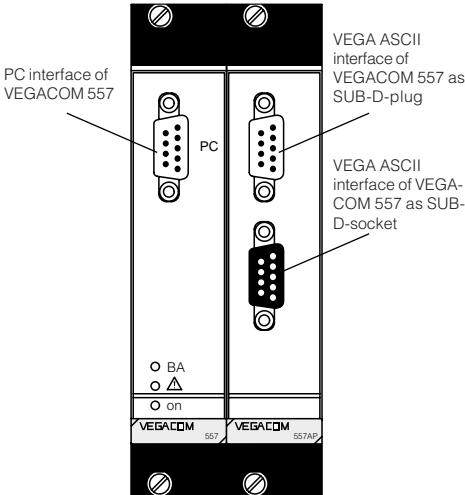

Front view with SUB-D-connections of VEGACOM 557 and VEGACOM 557AP

### 3 Switch settings on VEGACOM 557

For adjustment of the interfaces or the BUS parameters of the PC interface and the VEGA ASCII interfaces, various DIL switches are provided on VEGACOM 557. Before inserting VEGACOM 557 into the carrier or the housing, the DIL switches must be set according to the user-specific data. The data of these settings will be effective with the next initialization (switching on of voltage).

#### 3.1 Adjustment of the PC interface

For adjustment of the RS 232 PC interface in the front panel of VEGACOM 557, a 6-pole DIL switch block is located on the basic board. The PC interface is used for communication between a PC and VEGACOM 557, by means of the adjustment software VVO or the visualisation software VV.

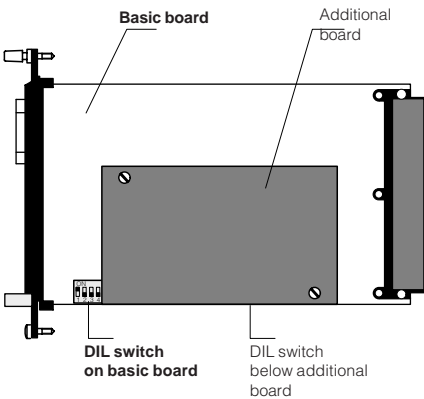

Side view of VEGACOM 557

#### Instrument number

Only relevant when operating two VEGACOM 557 on the same DISBUS. If two VEGACOM 557 are operated on the DISBUS, different instrument numbers have to be assigned.

Not relevant for operation on LOGBUS.

#### Automatic modem initialization

In position "ON" the modem will be initialized automatically when connecting it to the VEGACOM interface.

#### Transmission rate

For VVO or VV, the transmission rate must be set to 9600 baud.

In the following diagram, you see all possible adjustment possibilities for configuration of the PC interface.

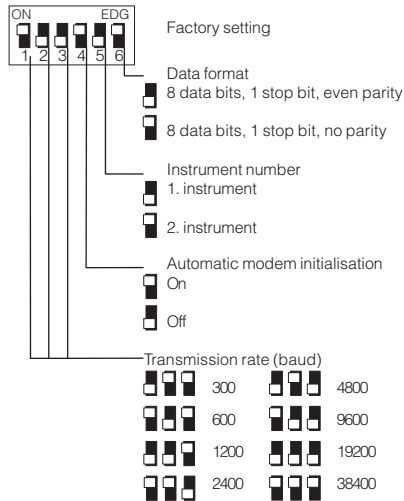

Possible settings of the DIL switch on the basic board

#### Data format

Parity can be switched from **even** to **no** parity (note for VVO including version 2.15, even parity is compulsory).

## 3.2 Adjustment of the VEGA ASCII interface

Three 8-pole DIL switch blocks as well as two hook switches for configuration of the VEGA ASCII interface to the DCS or the PLC are located on the additional board.

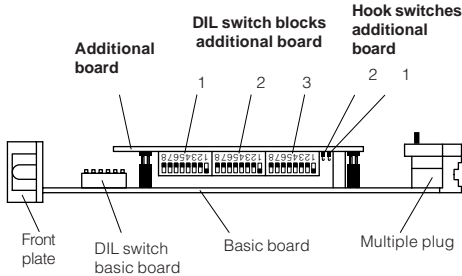

Bottom view of VEGACOM 557

The following adjustments for the VEGA ASCII are made through these DIL-switch blocks:

### Switch 1

- selection of the interface type
- activation of the bus termination
- selection of the protocol

### Switch 2

- selection of the baud rate
- number of data bits
- mode for parity bit
- resolution
- definition of the measured value image

### Switch 3

- VEGA ASCII address of VEGACOM 557

### Note:

When holding VEGACOM 557 for adjustment of the DIL-switches 1 to 3 (shown in illustration 2.10), the following switch representation can be applied directly.

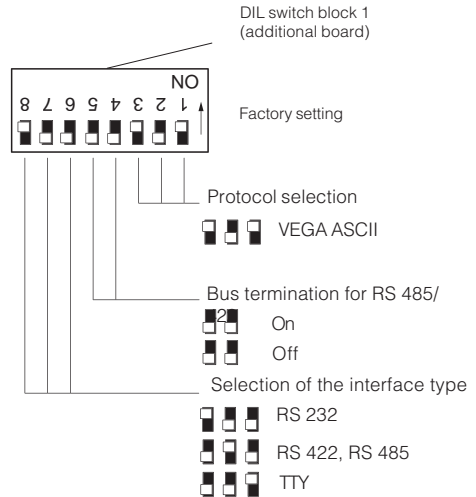

Possible settings of DIL switch block 1 on the additional board

### Note:

When selecting the interfaces TTY and RS 232, the hook switches must also be set to the respective position.

Activation of the bus termination on RS 485 is necessary when VEGACOM 557 is the last participant. General rule: The first and the last bus participant must be operated with bus termination activated.

When using interface RS 422, the bus termination must always be activated on VEGACOM 557.

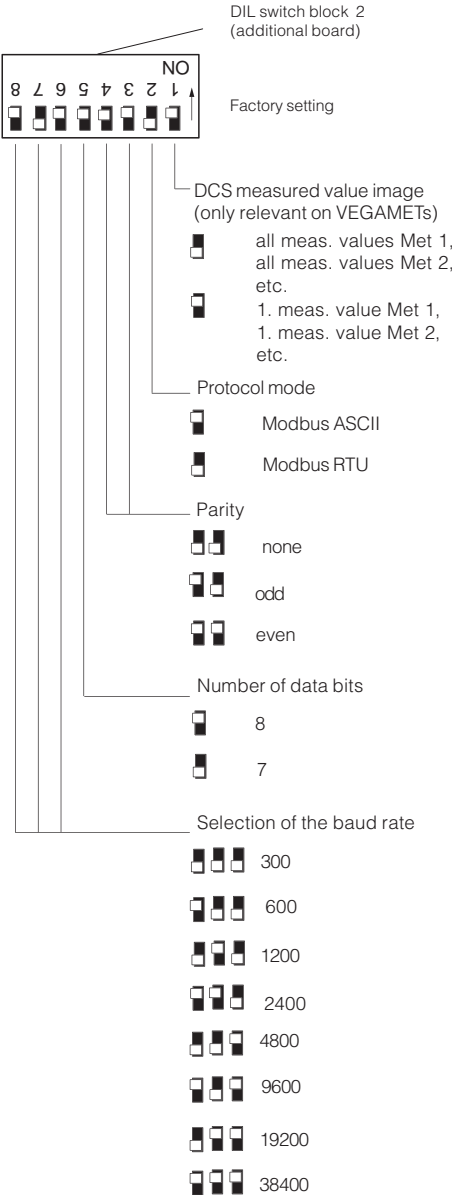

Possible settings of DIL switch block 2 on additional board

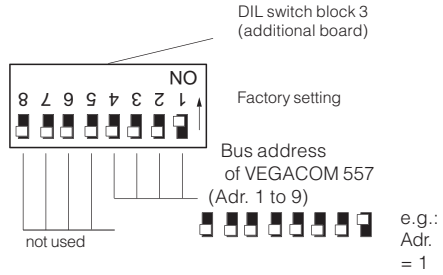

Possible settings of DIL switch block 3 on additional board

**Note:**

With the switch for the adjustment of the bus address (DIL-switch block 3), it is theoretically possible to set addresses in the range of 0 to 15. However, in reality only address 1 to 9 can be directly set. Address settings outside the range are converted to address 9.

Address 0 cannot be used, as it is used as broadcast address.

**Hook switches (additional board)**

The hook switches on the additional board enable selection between TTY and RS 232 interface. The additional print has to be removed from the basic print to modify the settings. The following illustration shows the removed additional print.

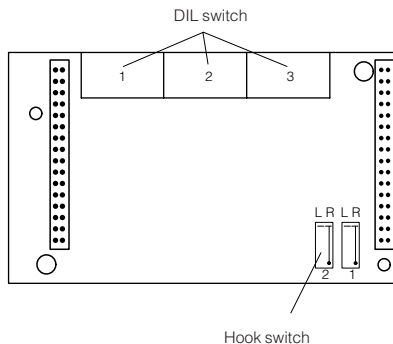

View of the dismantled additional print

Depending on the requirements, the VEGA ASCII interface can be used as TTY interface but also as RS 232 interface (using the hook switches). Illustration 2.15 shows the respective switch positions. As a rule, VEGACOM 557 is delivered with RS 232 activated.

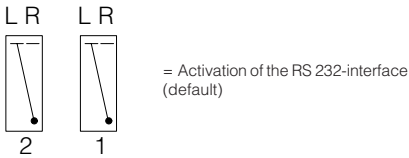
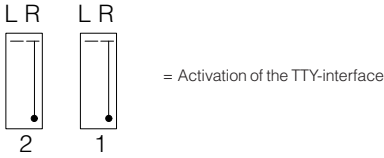

Note:

L = left position, R = right position

*Allocation of the switch positions (hook switch on the additional print)*

## 4 Data image in VEGACOM 557

VEGACOM 557 collects the measured values of the VEGA signal conditioning instruments VEGAMET 509, 512, 513, 514, 515 and 614 (via DISBUS) or VEGALOG 571 (via LOGBUS) and puts them in the temporary memory for collection via the VEGA ASCII.

The method of storing the measured values (for the higher-priority processing systems) in the VEGACOM 557 temporary memory differs depending on the selected configuration. It depends on whether VEGACOM 557 is connected to the DISBUS or the LOGBUS, and if DISBUS, also on the connected instrument type. However, it can be also influenced by VEGACOM 557 itself via DIL switches.

### Note

On the VEGAMET 513, 514, 515 and 614 signal conditioning instruments, as well as on the VEGALOG 571 processing system, the individual configuration of the DCS outputs with the adjustment software VVO is possible.

On VEGAMET 513, 514, 515 and 614 signal conditioning instruments as well as the VEGALOG 571 processing system, it is additionally possible to enquire the conditions of the contact inputs and outputs via VEGACOM 557.

### Enquiry of DCS values from DISBUS

The addressing of the measured values for VEGA ASCII is made instrument-orientated for the DISBUS enquiry. I.e. the measured values are enquired individually for each VEGAMET.

Series 509 and 512 instruments deliver max. 3 measured values. The number of measured values can be configured on the instrument. On series 513, 514, 515 and 614 instruments, the number of measured values (max. 7) can be set via the adjustment program VVO or directly on the instrument.

Due to these two different series, it is necessary to use two different telegrams for the enquiry of measured values. With enquiry "P" 3 values are transmitted. With enquiry "M", VEGACOM 557 delivers a total of 7 measured values.

If one or several DCS outputs have been assigned on the instrument, the respective measured value is provided with an error information during transmission. It is then possible to distinguish between valid and invalid values.

All values of an instrument are placed one after the other.

### Resolution

A selection between two resolutions of the value range is possible:

1 low resolution: (switch 2.2 = OFF)  
between -999.9 and +999.9

2 high resolution: (switch 2.2 = ON)  
between -999999 and +999999  
(actually only the range between  
-32768 and +32767 is used)

In addition to the above mentioned possibilities, the DCS values can be read out as a block. Here also there are two different possible configurations.

In the first configuration, a total of 16 DCS values are reserved for each VEGAMET. The instruments are then imaged in the memory according to their address.

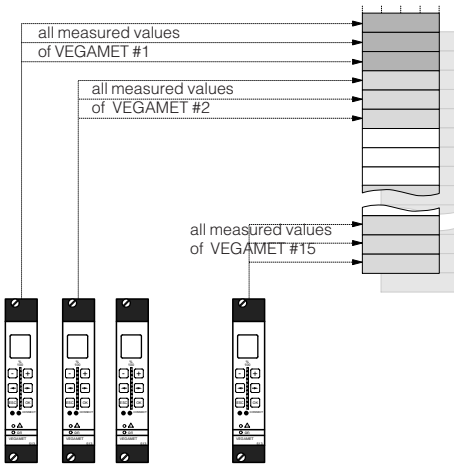

Grouping of measured values acc. to VEGAMET addresses

The second configuration images first all DCS values with the number 1, then DCS values with the number 2 etc.

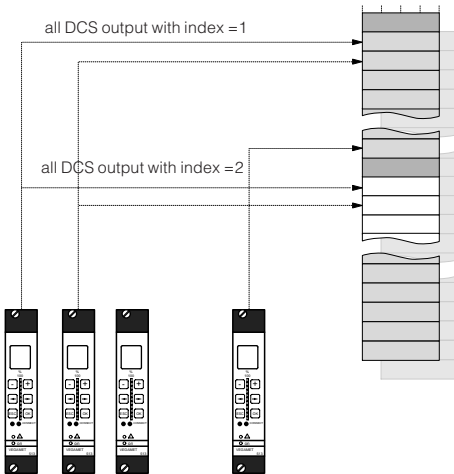

Grouping of measured values acc. to DCS indices or channels

### Enquiry of DCS values on LOGBUS

The numbering of the DCS values is made for LOGBUS between 001 and 255. This assignment is prepared via the parameter tool VVO. Each DCS value is therefore marked clearly. With the enquiry "%" and the DCS number, the values can be read out of VEGACOM 557 as single enquiry, range enquiry or as total block.

### 4.1 Enquiry for VEGAMET with three or less values per instrument

#### Low resolution = Switch 2.2 = OFF

VEGAMET series 509 and 512 instruments have max. 3 DCS outputs. Series 513, 514 and 515 instruments can assign max. 7 DCS outputs. If max. 3 DCS outputs are used with these instruments, the following telegram can be used for data transmission:

#### Telegram from processing system to VEGACOM 557

	Identifier	Address VEGACOM	Address VEGAMET	End identification
No. of bytes	1	1	2	1
Range (ASCII)	p (P)	0..9	01..15	CR

Example	p	1	02	CR
---------	---	---	----	----

Identifier: 1 character, optional "P" or "p"  
 End identification: 1 character Chr (13) = CR = Carriage Return  
 Total length of the telegram: 5 characters

#### Answer of VEGACOM 557

	S1	Addr COM	Addr MET	S2	DCS value1	T1	DCS value2	T2	DCS value3	T3	Error info	End identification
No. of bytes	1	1	1	1	7	1	7	1	7	1	1	2
Range (ASCII)	=	0..9	01..15	#	ASCII	p	ASCII	p	ASCII	p	0..7	CRLF

Example	=	1	02	#	17.2	p	38.4	p	45.7	p	0	CRLF
---------	---	---	----	---	------	---	------	---	------	---	---	------

Start character: S1 = 1 character "="  
 Start character: S2 = "#"  
 Separating character: T1, T2, T3 = per 1 character "p"  
 Total length of the telegram: 32 characters

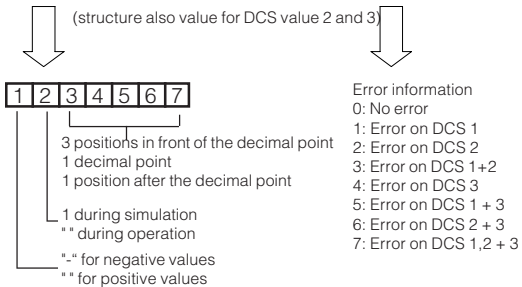

### High resolution = switch 2.2 = ON

The same enquiry can also be carried out with high resolution. The enquiry to VEGACOM 557 remains the same, in the answer more characters are used for the presentation of the measured value.

#### Telegram from processing system to VEGACOM 557

	Identifier	Address VEGACOM	Address VEGAMET	End identification
No. of bytes	1	1	2	1
Range (ASCII)	p (P)	0..9	01..15	CR

Example	p	1	02	CR
---------	---	---	----	----

Identifier: 1 character, optional "P" or "p"  
 End identification: 1 character Chr (13) = CR = Carriage Return  
 Total length of the telegram: 5 characters

#### Answer of VEGACOM 557

	S1	Addr COM	Addr MET	S2	DCS Value1	T1	DCS Value2	T2	DCS Value3	T3	Error info	End identification
No. of bytes	1	1	1	1	7	1	7	1	7	1	1	2
Range (ASCII)	=	0..9	01..15	#	ASCII	p	ASCII	p	ASCII	p	0..7	CRLF

Example	=	1	02	#	00172	p	00384	p	00457	p	0	CRLF
---------	---	---	----	---	-------	---	-------	---	-------	---	---	------

Start character: S1 = 1 character "="  
 Start character: S2 = "#"  
 Separating character: T1,T2,T3 = per 1 character "p"  
 Total length of the telegram: 32 characters

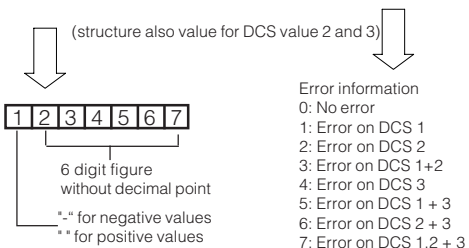

## 4.2 Enquiry for VEGAMET with up to seven values per instrument

### Low resolution = switch 2.2 = OFF

VEGAMET instruments can be provided with up to 7 DCS outputs. With this telegram, it is possible to read all DCS values from one instrument.

#### Telegram from processing system to VEGACOM 557

	Identifier	Address VEGACOM	Address VEGAMET	End identification
No. of bytes	1	1	2	1
Range (ASCII)	m (M)	0..9	01..15	CR

<b>Example</b>	m	1	2	CR
----------------	---	---	---	----

Identifier: 1 character, optional "M" or "m"  
 End identification: 1 character Chr (13) = CR = Carriage Return  
 Total length of the telegram: 5 characters

#### Answer of VEGACOM 557

	S1	Addr COM	Addr MET	S2
No. of bytes	1	1	1	1
Range (ASCII)	=	0..9	01..15	#

7 X

DCS value2	T2
7	1
ASCII	p

T3	Error info	End identification
1	1	2
p	0..7	CRLF

<b>Example</b>	=	1	02	#
----------------	---	---	----	---

38.4	p
------	---

p	0	CRLF
---	---	------

Start character: S1 = 1 character "="  
 Start character: S2 = 1 character "#"  
 Separating character: Tx = per 1 character "p"  
 Total length of the telegram: 66 characters

(Structure is valid for all DCS values)

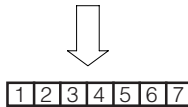

1 during simulation  
 "\*" during operation  
 "-" for negative values  
 "+" for positive values



- Error information
1. position
    - 0: No error on DCS 1,2,3
    - 1: Error on DCS 1
    - 2: Error on DCS 2
    - 3: Error on DCS 1+2
    - 4: Error on DCS 3
    - 5: Error on DCS 1 + 3
    - 6: Error on DCS 2 + 3
    - 7: Error on DCS 1,2 + 3
  2. position
    - 0: No error on DCS 4,5,6
    - 1: Error on DCS 4
    - 2: Error on DCS 5
    - 3: Error on DCS 4+5
    - 4: Error on DCS 6
    - 5: Error on DCS 4 + 6
    - 6: Error on DCS 5 + 6
    - 7: Error on DCS 4,5 + 6
  3. position
    - 0: No error on DCS 7
    - 1: Error on DCS 7

### High resolution = switch 2.2 = ON

The same resolution can also be carried out with high resolution. The enquiry to VEGACOM 557 remains the same, however the answer, has more characters for the presentation of the measured value.

#### Telegram from processing system to VEGACOM 557

	Identifier	Address VEGACOM	Address VEGAMET	End identification
No. of bytes	1	1	2	1
Range (ASCII)	m (M)	0..9	01..15	CR

Example	m	1	2	CR
---------	---	---	---	----

Identifier: 1 character, optional "M" or "m"  
 End identification: 1 character Chr (13) = CR = Carriage Return  
 Total length of the telegram: 5 characters

#### Answer of VEGACOM 557

	S1	Addr COM	Addr MET	S2
No. of bytes	1	1	1	1
Range (ASCII)	=	0..9	01..15	#

7 X

DCS value2	T2
7	1
ASCII	p

T3	Error info	End identification
1	1	2
p	0..7	CRLF

Example	=	1	02	#
---------	---	---	----	---

-00384	p
--------	---

p	0	CRLF
---	---	------

Start character: S1 = 1 character "="  
 Start character: S2 = 1 character "#"  
 Separating character: Tx = per 1 character "p"  
 Total length of the telegram: 66 characters

(structure is valid for all DCS values)

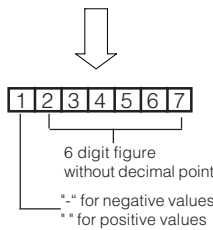

- Error information
1. position
    - 0: No error on DCS 1,2,3
    - 1: Error on DCS 1
    - 2: Error on DCS 2
    - 3: Error on DCS 1+2
    - 4: Error on DCS 3
    - 5: Error on DCS 1+3
    - 6: Error on DCS 2+3
    - 7: Error on DCS 1,2+3
  2. position
    - 0: No error on DCS 4,5,6
    - 1: Error on DCS 4
    - 2: Error on DCS 5
    - 3: Error on DCS 4+5
    - 4: Error on DCS 6
    - 5: Error on DCS 4+6
    - 6: Error on DCS 5+6
    - 7: Error on DCS 4,5+6
  3. position
    - 0: No error on DCS 7
    - 1: Error on DCS 7

### 4.3 Enquiry as block with low resolution

**Low resolution = switch 2.2 = OFF**

This telegram reads in all DCS values, i.e. 255 values are always transferred together. Each DCS value is provided with a number. Depending on the position of switch 2.1, the DCS values are arranged differently. The assignment of the DCS numbers to the VEGAMET addresses is stated in supplement A.

#### Telegram from processing system to VEGACOM 557

	Identifier	End identification
No. of bytes	1	1
Range (ASCII)	%	CR

<b>Example</b>	%	CR
----------------	---	----

Identifier: 1 character, "%"  
 End identification: 1 character Chr (13) = CR = Carriage Return  
 Total length of the telegram: 2 characters

#### Answer of VEGACOM 557

255 repetitions

	S1	DCS no.	S2	DCS value2	End identification
No. of bytes	1	3	1	5-6	2
Range (ASCII)	=	001..255	#	DCS value or fault	%CR

<b>Example</b>	=	001	#	-067.3	%CR
----------------	---	-----	---	--------	-----

Start character: S1 = 1 character "="  
 Start character: S2 = 1 character "#"  
 Total length of the telegram: 255 \* 12 or 13 characters

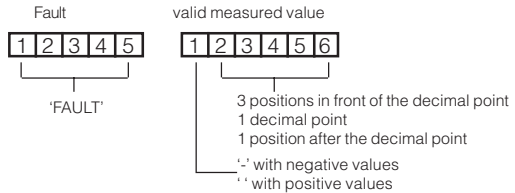

### High resolution = switch 2.2 = ON

The same enquiry can also be carried out with high resolution. The enquiry to VEGACOM 557 remains the same, however in the answer, more characters are used for presentation of the measured value.

#### Telegram from processing system to VEGACOM 557

	Identifier	End identification
No. of bytes	1	1
Range (ASCII)	%	CR

<b>Example</b>	%	CR
----------------	---	----

Identifier: 1 character, "%"

End identification: 1 character Chr (13) = CR = Carriage Return

Total length of the telegram: 2 characters

#### Answer of VEGACOM 557

255 repetitions

	S1	DCS no.	S2	DCS value2	End identification
No. of bytes	1	3	1	7	2
Range (ASCII)	=	001..255	#	DCS value of fault	%CR

<b>Example</b>	=	001	#	-000673	%CR
----------------	---	-----	---	---------	-----

Start character: S1 = 1 character "="

Start character: S2 = 1 character "#"

Total length of the telegram: 255 \* 14 characters

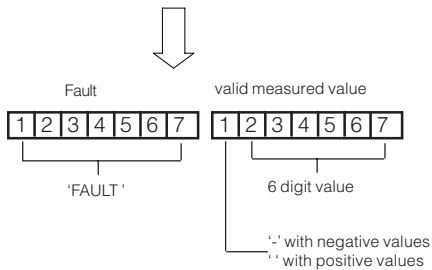

### 4.4 Enquiry as single value with low resolution

#### Low resolution = switch 2.2 = OFF

This telegram reads in a DCS value from VEGACOM 557. Depending on the position of switch 2.1., the DCS values are arranged differently. The assignment of the DCS numbers to the VEGAMET addresses is stated in supplement A.

#### Telegram from processing system to VEGACOM 557

	Identifier	DCS number	End identification
No. of bytes	1	3	1
Range (ASCII)	%	001..255	CR

Example	%	001	CR
---------	---	-----	----

Identifier: 1 character, "%"  
 End identification: 1 character Chr (13) = CR = Carriage Return  
 Total length of the telegram: 5 characters

#### Answer of VEGACOM 557

One repetition

	S1	DCS no.	S2	DCS value2	End identification
No. of bytes	1	3	1	5-6	2
Range (ASCII)	=	001..255	#	DCS value or fault	%CR

Example	=	001	#	-067.3	%CR
---------	---	-----	---	--------	-----

Start character: S1 = 1 character "="  
 Start character: S2 = 1 character "#"  
 Total length of the telegram: 12 or 13 characters

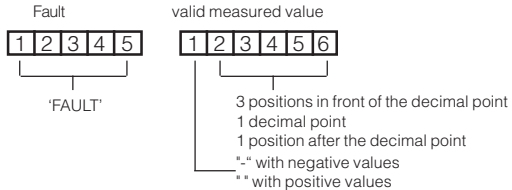

### High resolution = switch 2.2 = ON

The same enquiry can also be carried out with high resolution. The enquiry to VEGACOM 557 remains the same, however in the answer, more characters are used for the presentation of the measured value.

#### Telegram from processing system to VEGACOM 557

	Identifier	DCS number	End identification
No. of bytes	1	3	1
Range (ASCII)	%	001..255	CR

Example	%	001	CR
---------	---	-----	----

Identifier: 1 character, "%"   
 End identification: 1 character Chr (13) = CR = Carriage Return   
 Total length of the telegram: 5 characters

#### Answer of VEGACOM 557

One repetition

	S1	DCS no.	S2	DCS value2	End identification
No. of bytes	1	3	1	7	2
Range (ASCII)	=	001..255	#	DCS value or fault	%CR

Example	=	001	#	-000673	%CR
---------	---	-----	---	---------	-----

Start character: S1 = 1 character "="   
 Start character: S2 = 1 character "#"   
 Total length of the telegram: 13 characters

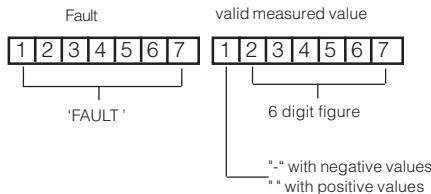

### 4.5 Enquiry as range with low resolution

#### Low resolution = switch 2.2 = OFF

This telegram reads in a DCS value from VEGACOM 557. Depending on the position of the switch 2.1, the DCS values are arranged differently. The assignment of the DCS numbers to the VEGAMET addresses is stated in supplement A.

#### Telegram from processing system to VEGACOM 557

	Identifier	DCS number	T1	Number	End identification
No. of bytes	1	3	1	3	1
Range (ASCII)	%	001..255	L	001..255	CR

Example	%	001	L	001	CR
---------	---	-----	---	-----	----

Identifier: 1 character, "%"  
 T1 : Separating character = 1 character "L"  
 End identification: 1 character Chr (13) = CR = Carriage Return  
 Total length of the telegram: 9 characters

#### Answer of VEGACOM 557

n (n= stated number) repetitions

	S1	DCS no.	S2	DCS value2	End identification
No. of bytes	1	3	1	5-6	2
Range (ASCII)	=	001..255	#	DCS value or fault	%CR

Example	=	001	#	-067.3	%CR
---------	---	-----	---	--------	-----

Start character: S1 = 1 character "="  
 Start character: S2 = 1 character "#"  
 Total length of the telegram: 12 or 13 characters

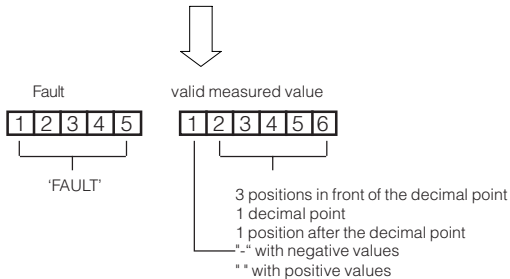

### High resolution = switch 2.2 = ON

The same enquiry can also be carried out with high resolution. The enquiry to VEGACOM 557 remains the same, however in the answer, more characters are used for the presentation of the measured value.

#### Telegram from processing system to VEGACOM 557

	Identifier	DCS number	T1	Number	End identification
No. of bytes	1	3	1	3	1
Range (ASCII)	%	001..255	L	001..255	CR

Example	%	001	L	001	CR
---------	---	-----	---	-----	----

Identifier: 1 character, "%"  
 T1 : Separating character = 1 character "L"  
 End identification: 1 character Chr (13) = CR = Carriage Return  
 Total length of the telegram: 9 characters

#### Answer of VEGACOM 557

n (n= stated number) repetitions

	S1	DCS no.	S2	DCS value2	End identification
No. of bytes	1	3	1	7	2
Range (ASCII)	=	001..255	#	DCS value or fault	%CR

Example	=	001	#	-000673	%CR
---------	---	-----	---	---------	-----

Start character: S1 = 1 character "="  
 Start character: S2 = 1 character "#"  
 Total length of the telegram: n \* 14 characters

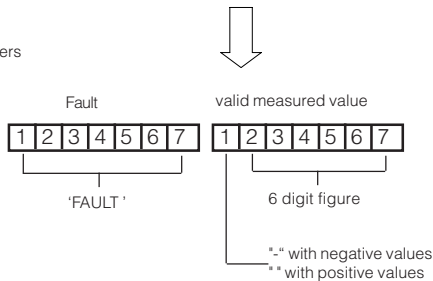

### 4.6 Enquiry as block with address and low resolution

#### Low resolution = switch 2.2 = OFF

This telegram reads in all DCS values of VEGACOM 557 with the assigned address, i.e. 255 are always transferred together. Each DCS value is provided with a number. Depending on the position of switch 2.1, the DCS values are arranged differently. The assignment of the DCS numbers to the VEGAMET addresses is stated in supplement A.

#### Telegram from processing system to VEGACOM 557

	Identifier	Address	T1	End identification
No. of bytes	1	1	1	1
Range (ASCII)	%	0..9	,	CR

Example	%	2	,	CR
---------	---	---	---	----

Identifier: 1 character, "%"  
 T1: 1 character "," (comma)  
 End identification: 1 character Chr (13) = CR = Carriage Return  
 Total length of the telegram: 4 characters

#### Answer of VEGACOM 557

255 repetitions

	S1	Adr	T1	DCS no.	S2	DCS value2	End identification
No. of bytes	1	1	1	3	1	5-6	2
Range (ASCII)	=	0..9	,	001..255	#	DCS value or fault	%CR

Example	=	2	,	001	#	-067.3	%CR
---------	---	---	---	-----	---	--------	-----

Start character: S1 = 1 character "="  
 Address : Adr = 1 character VEGACOM 557 address  
 Separating character: T1 = 1 character "," (comma)  
 Start character: S2 = 1 character "#"  
 Total length of the telegram: 255 \* 14 or 15 characters

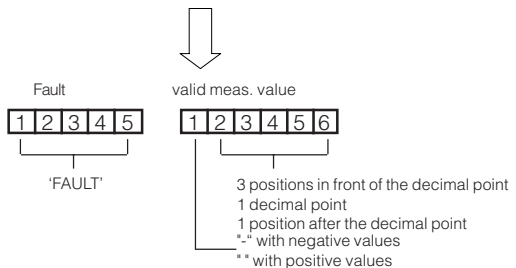

### High resolution = switch 2.2 = ON

The same enquiry can also be carried out with high resolution. The enquiry to VEGACOM 557 remains the same, however in the answer, more characters are used for the presentation of the measured value.

#### Telegram of processing system to VEGACOM 557

	Identifier	Address	T1	End identification
No. of bytes	1	1	1	1
Range (ASCII)	%	0..9	,	CR

<b>Example</b>	%	2	,	CR
----------------	---	---	---	----

Identifier: 1 character, "%"  
 T1: 1 character ",", (comma)  
 End identification: 1 character Chr (13) = CR = Carriage Return  
 Total length of the telegram: 4 characters

#### Answer of VEGACOM 557

255 repetitions

	S1	Adr	T1	DCS no.	S2	DCS value2	End identification
No. of bytes	1	1	1	3	1	7	2
Range (ASCII)	=	0..9	,	001..255	#	DCS value or fault	%CR

<b>Example</b>	=	2	,	001	#	-000673	%CR
----------------	---	---	---	-----	---	---------	-----

Start character: S1 = 1 character "="  
 Address: Adr = 1 character VEGACOM 557 address  
 Separating character: T1 = 1 character ",", (comma)  
 Start character: S2 = 1 character "#"  
 Total length of the telegram: 255 \* 16 characters

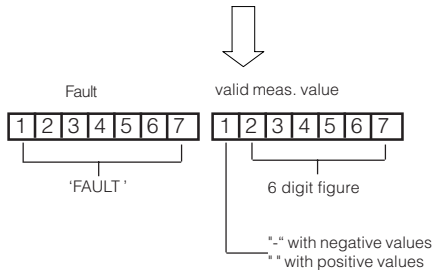

## 4.7 Enquiry as single value with address and low resolution

### Low resolution = switch 2.2 = OFF

This telegram reads exactly one DCS value. Depending of the position of the switch 2.1, the DCS values are arranged differently. The assignment of the DCS number to the VEGAMET addresses is stated in supplement A. In addition to chapter "4.6 Enquiry as block with address and low resolution", an address from 0 to 9 is transferred so that several VEGACOM 557 can be operated on one BUS system (e.g. via a RS 485 interface)

### Telegram from processing system to VEGACOM 557

	Identifier	Address	T1	DCS number	End identification
No. of bytes	1	1	1	3	1
Range (ASCII)	%	0..9	,	001..255	CR

Example	%	2	,	001	CR
---------	---	---	---	-----	----

Identifier: 1 character, "%"  
 T1: 1 character ", " (comma)  
 End identification: 1 character Chr (13) = CR = Carriage Return  
 Total length of the telegram: 7 characters

### Answer of VEGACOM 557

One repetition

	S1	Addr	T1	DCS no.	S2	DCS value2	End identification
No. of bytes	1	1	1	3	1	5-6	2
Range (ASCII)	=	0..9	,	001..255	#	DCS value or fault	%CR

Example	=	2	,	001	#	-067.3	%CR
---------	---	---	---	-----	---	--------	-----

Start character: S1 = 1 character "="  
 Address: Addr = 1 character VEGACOM 557 address  
 Separating character: T1 = 1 character ", " (comma)  
 Start character: S2 = 1 character "#"  
 Total length of the telegram: 14 or 15 characters

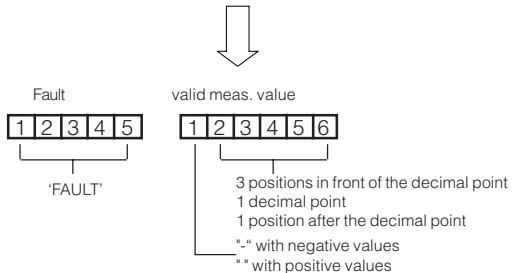

### High resolution = switch 2.2 = ON

The same enquiry can also be carried out with high resolution. The enquiry of VEGACOM 557 remains the same, however in the answer, more characters are used for the presentation of the measured value.

#### Telegram from processing system to VEGACOM 557

	Identifier	Address	T1	DCS number	End identification
No. of bytes	1	1	1	3	1
Range (ASCII)	%	0..9	,	001..255	CR

Example	%	2	,	001	CR
---------	---	---	---	-----	----

Identifier: 1 character, "%"   
 T1: 1 character ",", (comma)   
 End identification: 1 character Chr (13) = CR = Carriage Return   
 Total length of the telegram: 7 characters

#### Answer of VEGACOM 557

One repetition

	S1	Adr	T1	DCS no.	S2	DCS value2	End identification
No. of bytes	1	1	1	3	1	7	2
Range (ASCII)	=	0..9	,	001..255	#	DCS value or fault	%CR

Example	=	2	,	001	#	-000673	%CR
---------	---	---	---	-----	---	---------	-----

Start character: S1 = 1 character "="   
 Address: Adr = 1 character VEGACOM 557 address   
 Separating character: T1 = 1 character ",", (comma)   
 Start character: S2 = 1 character "#"   
 Total length of the telegram: 16 characters

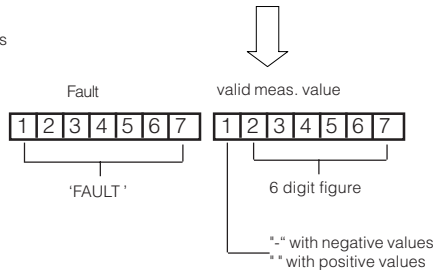

### 4.8 Enquiry as range with address and low resolution

#### Low resolution = switch 2.2 = OFF

This telegram reads in a range of DCS values. The number is transferred with the enquiry. Depending on the position of the switch 2.1, the DCS values are arranged differently. The assignment of the DCS numbers to the VEGAMET addresses is stated in supplement A. In addition to chapter "4.6 Enquiry as block with address and low resolution" another address from 0 to 9 is transferred, so that several VEGACOM 557 can be operated on one BUS system (e.g. via a RS 485 interface).

#### Telegram from processing system to VEGACOM 557

	Identifier	Address	T1	DCS number	T1	DCS number	End identification
No. of bytes	1	1	1	3	1	3	1
Range (ASCII)	%	0..9	,	001..255	L	001..255	CR

Example	%	2	,	001	L	2	CR
---------	---	---	---	-----	---	---	----

Identifier: 1 character, "%"  
 T1: 1 character "," (comma)  
 T2: 1 character "L"  
 End identification: 1 character Chr (13) = CR = Carriage Return  
 Total length of the telegram: 11 characters

#### Answer of VEGACOM 557

n (n= stated number) repetitions

	S1	Addr	T1	DCS no.	S2	DCS value2	Ende identification
No. of bytes	1	1	1	3	1	5-6	2
Range (ASCII)	=	0..9	,	001..255	#	DCS value or fault	%CR

Example	=	2	,	001	#	-067.3	%CR
---------	---	---	---	-----	---	--------	-----

Start character: S1 = 1 character "="  
 Address: Addr = 1 character VEGACOM 557 address  
 Separating character: S2 = 1 character "," (comma)  
 Start character: S3 = 1 character "#"  
 Total length of the telegram: 14 or 15 characters

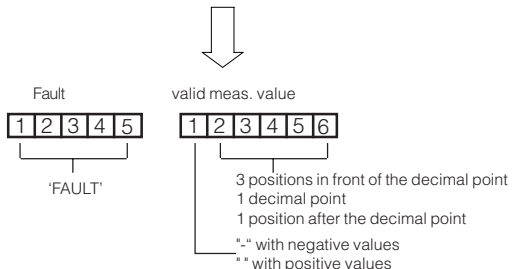

### High resolution = switch 2.2 = ON

The same enquiry can also be carried out with high resolution. The enquiry to VEGACOM 557 remains the same, however in the answer, more characters are used for the presentation of the measured value.

#### Telegram from processing system to VEGACOM 557

	Identifier	Address	T1	DCS number	T1	DCS number	End identification
No. of bytes	1	1	1	3	1	3	1
Range (ASCII)	%	0..9	,	001..255	L	001..255	CR

Example	%	2	,	001	L	2	CR
---------	---	---	---	-----	---	---	----

Identifier: 1 character, "%"   
 T1: 1 character ", " (comma)   
 T2: 1 character "L"   
 End identification: 1 character Chr (13) = CR = Carriage Return   
 Total length of the telegram: 11 characters

#### Answer of VEGACOM 557

n (n= stated number) repetitions

	S1	Addr	T1	DCS no.	S2	DCS value2	End identification
No. of bytes	1	1	1	3	1	7	2
Range (ASCII)	=	0..9	,	001..255	#	DCS value or fault	%CR

Example	=	2	,	001	#	-000673	%CR
---------	---	---	---	-----	---	---------	-----

Start character: S1 = 1 character "="   
 Address: Addr = 1 characters VEGACOM 557 address   
 Separating character: S2 = 1 character ", " (comma)   
 Start character: S3 = 1 character "#"   
 Total length of the telegram: 16 characters

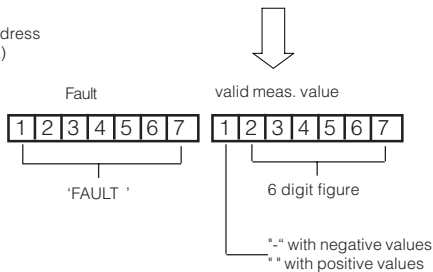

### 4.9 Enquiry for the contact inputs and outputs on DISBUS

During operation on DISBUS via VEGACOM 557, the contacts are assigned by means of the VEGAMET address. The enquiry is then made with the VEGAMET address.

#### Telegram from processing system to VEGACOM 557 for enquiry of a VEGAMET

	Identifier	Address COM	Address MET	End identification
No. of bytes	1	1	2	1
Range (ASCII)	R	0..9	01..15	CR
<b>Example</b>	R	2	01..15	CR

#### Telegram from processing system to VEGACOM 557 for enquiry of several VEGAMET

	Identifier	Address COM	Address MET	T1	No.	End identification
No. of bytes	1	1	2	1	2	1
Range (ASCII)	R	0..9	01..15	L	01..15	CR
<b>Example</b>	R	2	01	L	03	CR

Identifier: 1 character, "R"  
 T1: 1 character "L"  
 End identification: 1 character Chr (13) = CR = Carriage Return  
 Total length of the telegram: 5 or 8 characters

#### Answer of VEGACOM 557

1 or n (n= stated number) repetitions

	S1	Address COM	Address MET	S2	Contact value	T	Status	End identification
No. of bytes	1	1	2	1	6		1	1
Range (ASCII)	R	0..9	01..15	#	value	p	0..3	CRLF
<b>Example</b>	R	2	01	#	32896	p	0	CRLF

Start character: S1 = 1 character "="  
 Address: Addr = 1 character VEGACOM 557 address  
 Start character: S2 = 1 character "#"  
 Status: Validity of the contact value,  
 0 = Inputs and outputs valid, 1 = output contacts valid,  
 2 = Input contacts valid, 3 = value invalid,  
 End identification: CR LF = Carriage Return + Linefeed  
 Total length of the telegram: 15 characters

Contact value binary coded  
 32896 = 10000000 10000000

	Input contacts							Output contacts									
Meaning	S1	reserve					2	1	S2	reserve					ST	2	1
Bit position	15	14	13	12	11	10	9	8	7	6	5	4	3	2	1	0	

ST : Fail safe relay  
 S1 : Status for input contacts; value : 0 - input contacts are valid, value :1 - input contacts are not valid.  
 S2 : Status for output contacts; value : 0 - output contacts are valid, value :1 - output contacts are not valid.

### 4.10 Enquiry for the contact inputs and outputs on LOGBUS

During operation on LOGBUS via VEGACOM 557, the contacts are assigned by means of the module address. The enquiry is made with the module address.

#### Telegram from processing system to VEGACOM 557 for enquiry of a module

	Identifier	Address COM	Module	End identification
No. of bytes	1	1	2	1
Range (ASCII)	R	0..9	01..31	CR
<b>Example</b>	R	2	01..15	CR

#### Telegram of the processing system to VEGACOM 557 for enquiry of several modules

	Identifier	Address COM	Address MET	T1	No.	End identification
No. of bytes	1	1	2	1	2	1
Range (ASCII)	R	0..9	01..31	L	01..31	CR
<b>Example</b>	R	2	01	L	03	CR

Identifier: 1 character, "R"

T1: 1 character "L"

End identification: 1 character Chr (13) = CR = Carriage Return

Total length of the telegram: 5 or 8 characters

#### Answer of VEGACOM 557

1 or n (n= stated number) repetitions

	S1	Address COM	Module	S2	Contact value	T	Status	End identification
No. of bytes	1	1	2	1	6		1	1
Range (ASCII)	R	0..9	01..31	#	value	p	0..1	CRLF
<b>Example</b>	R	2	01	#	32896	p	0	CRLF

Start character: S1 = 1 character "="

Address: Addr = 1 character VEGACOM 557 address

Start character: S2 = 1 character "#"

Status: Validity of the contact value, 0 = value valid, 1 = value invalid.

End identification: CR LF = Carriage Return + Linefeed

Total length of the telegram: 15 characters

Contact value binary coded  
32768 = 10000000 00000000

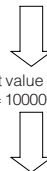

	Input contacts								Output contacts								
Meaning	S1	reserve						10	9	8	7	6	5	4	3	2	1
Bit position	15	14	13	12	11	10	9	8	7	6	5	4	3	2	1	0	

S1 : Status for contacts; 0 - contact information is valid, 1 - contact information is not valid.

### 4.11 Enquiry for the software version

With this enquiry, the software version in VEGACOM 557 can be determined.

#### Telegram from processing system to VEGACOM 557

	Identifier	Address VEGACOM	Reserve	Enquiry	End identification
No. of bytes	1	1	2	13	1
Range (ASCII)	%	0..9	00	READ VERSION	CR

<b>Example</b>	%	2	00	READ VERSION	CR
----------------	---	---	----	--------------	----

Identifier: 1 character, "v" ("V")

Request: 13 characters " READ VERSION" (in front of READ and in front of VERSION with 1 blank character)

End identification: 1 character Chr (13) = CR = Carriage Return

Total length of the telegram: 18 characters

#### Answer of VEGACOM 557

	Identifier	Address VEGACOM	Reserve	Enquiry	End identification
No. of bytes	1	1	2	17	2
Range (ASCII)	=	0..9	00	Answer text	CRLF

<b>Example</b>	=	2	00	VEGACOM557 V2.17	CRLF
----------------	---	---	----	------------------	------

Start character: S1 = 1 character "="

Address: Addr = 1 character VEGACOM 557 address

Reserve: 2 characters here "00"

Answer: 17 characters text

Total length of the telegram: 23 characters

### 4.12 Error information from VEGACOM 557

If an enquiry of VEGACOM 557 was not understood correctly or the transmission of the enquiry was faulty, VEGACOM sends an error information.

Error text	Meaning
"ERROR 5"	<ul style="list-style-type: none"> <li>- Identifier not recognised</li> <li>- Telegram incomplete</li> <li>- VEGAMET address not valid</li> </ul>
"ERROR 6"	Telegram cannot be evaluated

### 4.13 Parameter adjustment of VEGALOG or VEGAMET via VEGA ASCII

VEGACOM 557 also provides the option of enquiring and modifying different parameters of the VEGALOG or VEGAMET signal conditioning instruments (relating to measurement loop). The following list gives an overview of the affected parameters:

Parameter name	possible access mode	
Density	reading	writing
Relay switching point (top)	reading	writing
Relay switching point (bottom)	reading	writing
Integration time	reading	writing
Scaling (0 %)	reading	writing
Scaling (100 %)	reading	writing
Current offset	reading	writing
Activate offset adjustment	–	writing

Independent of the connected VEGA signal conditioning instrument (VEGAMET or VEGALOG), the enquiry or modification of parameters is made via the VEGA ASCII always according to the same procedure. Each enquiry starts with the identifier "?" followed by "R" for Read or "W" for Write as well as the identifier for the parameter. The telegrams are completed by the addresses of VEGACOM, VEGAMET and the component number as well as the value to be written.

If it was not possible to transfer the order to a connected instrument, a message with the value, or with information about the action just carried out, is returned.

For further information, please contact one of our employees.

## 5 Setup

### 5.1 Setup check list:

Proceed with the setup of VEGACOM 557 with VEGA ASCII as follows:

#### I. Check hardware requirements:

- VEGA ASCII-compatible Master component (Modus: RTU or ASCII)
- Check interface type (RS 232, RS 485, RS 422 or TTY)
- VEGACOM 557 version "VEGA ASCII"

#### II. Carry out adjustments on VEGACOM 557 (DIL switch on additional board):

- Set resolution for VEGA ASCII
- Set value arrangement for VEGA ASCII
- Activate interface type
- Set parameter for interface
- Set VEGA ASCII address

#### III. Provide VEGA ASCII connection and check communication:

- In case of correct communication, the green LED marked "BA" lights on VEGACOM 557.

### 5.2 Communication structure

Within the data communication between VEGACOM 557 and the connected processing system, the following functions are supported:

- Mode (VEGACOM 557 is slave)  
VEGACOM 557 does not transmit data without request. The Master has to request all required data.
- Instrument address (default value # 1)  
By using a bus-compatible interface (e.g. RS 485) the operation of up to 9 instruments on one interface is possible.
- Presentation:  
All telegrams use ASCII characters and are therefore readable as plain text.
- Time-based image:  
There are no time periods required for transmission.
- Value range (low resolution)  
Independent of the actual position of the decimal point, the value to be transferred is provided with a decimal point at the penultimate position.
- Value range (high resolution)  
The value to be transmitted is always transferred without decimal point.

The decimal point as well as the unit of measurement of the DCS value are not transferred by VEGACOM 557!

This information must be completed by the user in the software of the process data processing.

### 5.3 Setup example for the PC

#### Connections between PC and VEGACOM 557 with RS 232

VEGA ASCII via RS 232 C

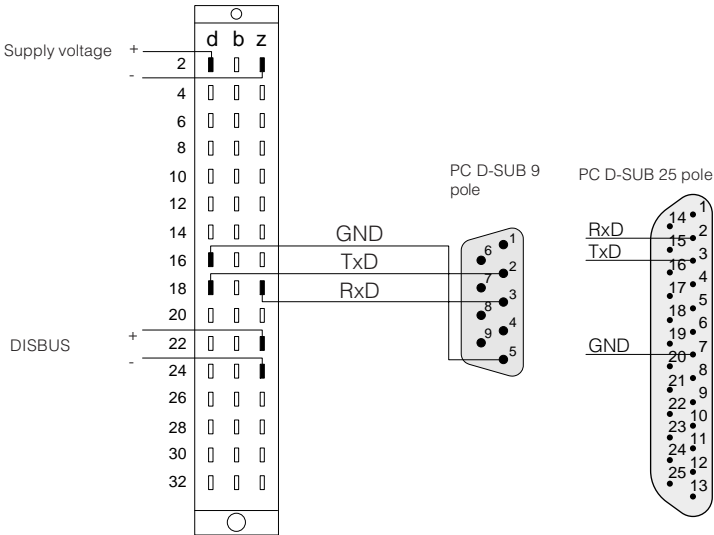

## Switch position on VEGACOM 557 additional print

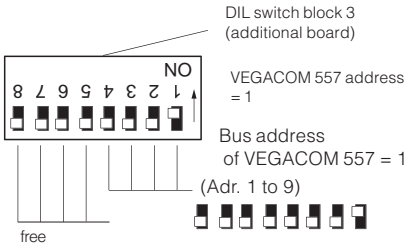
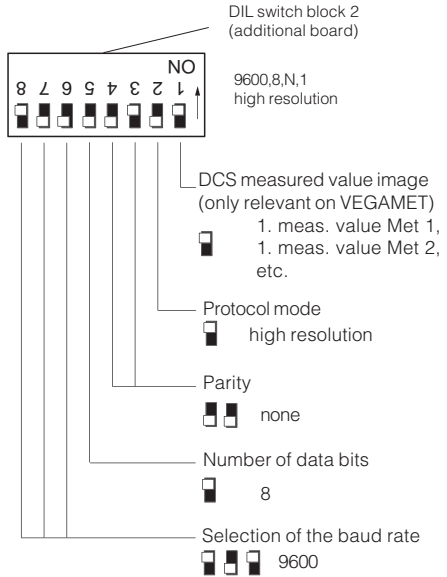
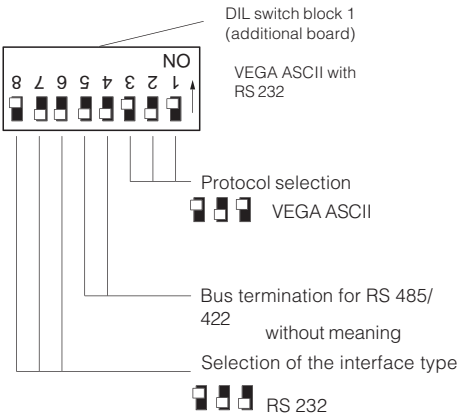

## 5.4 Example program for the enquiry VEGAMET (QUICK BASIC)

```

DECLARE SUB Receive String (n%, rec$)
DECLARE SUB Check Receive (rec AS STRING)
DECLARE SUB Output Data ()
DECLARE SUB Delay (t AS SINGLE)

' Konstanten definieren
CONST COMADR = "0"

CONST MAXNORECEIVE = 2

CONST FirstMet = 1
CONST LastMet = 15
CONST FirstPls = 1
CONST LastPls = 3

CONST CMD1 = "P"
CONST CMD2 = "M"

CONST COLORWHITE = 15
CONST COLORGREEN = 10
CONST COLORRED = 12

' Variablendefinition
DIM sio AS INTEGER
DIM i AS INTEGER
DIM j AS INTEGER
DIM L AS INTEGER

DIM Receive AS STRING
DIM Send AS STRING
DIM NoReceive (LastMet) AS INTEGER

DIM SHARED SendNr AS STRING
DIM SHARED MetNr AS INTEGER
DIM SHARED DCS(LastMet, LastPls) AS LONG
DIM SHARED Status(LastMet, LastPls) AS INTEGER

' Bildschirm loeschen
CLS
COLOR COLORWHITE, 0
' Freies Dateihandle holen
sio = FREEFILE
' Schnittstelle ohne Handshake Oeffnen
OPEN "COM2:9600,N,8,1,BIN,OP0,DS0,RS" FOR RANDOM AS sio

' Mit VEGAMET Adresse 1 beginnen
MetNr = FirstMet
' Fehlerzaehler initialisieren
FOR i = FirstMet TO LastMet
  NoReceive(i) = MAXNORECEIVE
  FOR j = FirstPls TO LastPls
    Status(i, j) = -1
  NEXT j
NEXT i
' Solange wiederholen bis der Anwender eine Taste
drueckt
WHILE INKEY$ = ""
  ' Sendestring erzeugen
  SendNr = RTRIM$(LTRIM$(STR$(MetNr)))

```

```

' mit fuehrenden Nullen auffuellen
SendNr = MID$(COMADR + "00", 1, 3 - LEN(SendNr)) +
SendNr

' Sendestring erzeugen
IF LastPls > 3 THEN
    Send = CMD2 + SendNr + CHR$(13)
ELSE
    Send = CMD1 + SendNr + CHR$(13)
END IF
' Sendestring auf der Schnittstelle ausgeben
' ; am Ende, damit kein 2. CR gesendet wird
PRINT #sio, Send;

' Info zur aktuellen Taetigkeit
LOCATE 1, 1
PRINT "Scan VEGAMET Adresse "; MetNr

' Auf Antwort vom VEGACOM warten ca 0.1 Sekunden
Delay (.1)
CALL ReceiveString(sio, Receive)
' Laenge pruefen
IF LastPls > 3 THEN
    L = 66
ELSE
    L = 32
END IF
IF LEN(Receive) = L THEN
    ' Keine Antwort Zaehler wieder auf Startwert
    NoReceive(MetNr) = MAXNORECEIVE
    ' Statusinformationen auf Fehler setzen
    FOR j = FirstPls TO LastPls
        Status(MetNr, j) = -1
    NEXT j
    CALL CheckReceive(Receive)
ELSE
    IF NoReceive(MetNr) > 0 THEN
        NoReceive(MetNr) = NoReceive(MetNr) - 1
    ELSE
        ' Stausinformationen auf Fehler setzen
        FOR j = FirstPls TO LastPls
            Status(MetNr, j) = -1
        NEXT j
    END IF
END IF
' naechste VEGAMET abfragen
MetNr = MetNr + 1
' Alle VEGAMET abgefragt ?
IF MetNr > LastMet THEN
    OutputData
    ' Wieder bei VEGAMET Adresse FirstMet beginnen
    MetNr = FirstMet
END IF
WEND
' Schnittstelle schliessen
CLOSE sio

```

```

END

SUB CheckReceive (rec AS STRING)
  DIM j AS INTEGER
  DIM L AS INTEGER
  DIM PLSString AS STRING
  DIM Stat AS INTEGER

  ' Carriage Return abpruefen
  IF MID$(rec, LEN(rec) - 1, 1) <> CHR$(13) THEN EXIT SUB
  ' Start character abpruefen
  IF MID$(rec, 1, 1) <> "=" THEN EXIT SUB
  ' Antwort auf aktuelle Anfrage ?
  IF MID$(rec, 2, 3) <> SendNr THEN EXIT SUB
  ' Separating character pruefen
  IF (MID$(rec, 5, 1) <> "#") THEN EXIT SUB
  FOR j = 0 TO LastPls - 1
    IF (MID$(rec, 13 + j * 8, 1) <> "p") THEN EXIT SUB
  NEXT j
  ' DCS Werte auslesen
  FOR j = FirstPls TO LastPls
    PLSString = MID$(rec, 6 + (j - 1) * 8, 7)
    ' Abfrage hohe or niedrige Aufloesung
    IF MID$(PLSString, 6, 1) = "." THEN
      ' niedrige Aufloesung
      PLSString = MID$(PLSString, 1, 1) +
MID$(PLSString, 3, 3) + MID$(PLSString, 7, 1)
    END IF
    DCS(MetNr, j) = VAL(PLSString)
  NEXT j
  ' Statusinformation lesen
  IF LastPls > 3 THEN
    Stat = VAL(MID$(rec, 62, 1))
    Stat = Stat + VAL(MID$(rec, 63, 1)) * 8
    Stat = Stat + VAL(MID$(rec, 64, 1)) * 64
  ELSE
    Stat = VAL(MID$(rec, 30, 1))
  END IF
  i = 1
  FOR j = FirstPls TO LastPls
    Status(MetNr, j) = Stat AND i
    i = i * 2
  NEXT j
END SUB

SUB Delay (t AS SINGLE)
  DIM x AS DOUBLE
  x = TIMER + t
  WHILE x >= TIMER
  WEND

```

```

END SUB

SUB OutputData
  DIM v AS STRING
  ' Ausgabe der Daten auf den Bildschirm
CLS
PRINT
PRINT
  FOR i = FirstMet TO LastMet
    PRINT "MET: "; i,
    FOR j = FirstPls TO LastPls
      v = LTRIM$(RTRIM$(STR$(DCS(i, j))))
      v = MID$(SPACE$(8), 1, 8 - LEN(v)) + v
      IF Status(i, j) = 0 THEN
        ' Status ist OK -> Anzeige in Gruen
        COLOR COLORGREEN, 0
      ELSE
        ' Fehler im Status -> Anzeige in Rot
        COLOR COLORRED, 0
      END IF
      PRINT v;
    NEXT j
    ' Anzeige in Weiss
    COLOR COLORWHITE, 0
    PRINT
  NEXT i
  ' Hinweis ausgeben
  PRINT
  PRINT "Zum Beenden bitte eine Taste druecken"
END SUB

SUB ReceiveString (n%, rec$)
  DIM DoLoop AS INTEGER
  DIM MaxLoop AS SINGLE

  ' Alle characters einlesen bis ein Linefeed gefunden
  wurde
  ' or 0.2 Sekunden verstrichen sind
  MaxLoop = TIMER + .1
  ' Empfangspuffer loeschen
  rec$ = ""
  DoLoop = 1
  WHILE DoLoop <> 0
    ' characters an der Schnittstelle vorhanden ?
    IF LOC(n%) > 0 THEN
      ' Ja dann lesen
      rec$ = rec$ + INPUT$(LOC(n%), #n%)
      IF MID$(rec$, LEN(rec$), 1) = CHR$(10) THEN
        DoLoop = 0
      END IF
    ELSE
      ' Zeit schon abgelaufen ?
      IF MaxLoop < TIMER THEN
        DoLoop = 0
      END IF
    END IF
  END IF
WEND
END SUB

```

## 5.5 Example program for the enquiry VEGALOG (VISUAL BASIC 4.0)

```

VEGAASCII.VBP
Form=vegaascii.frm
Object={648A5603-2C6E-101B-82B6-000000000014}#1.1#0;
MSCOMM32.OCX
ProjWinSize=168,207,248,215
ProjWinShow=2
IconForm="ASCDEMO"
HelpFile=""
Command=""
Name="ASCII"
HelpContextID="0"
StartMode=0
VersionCompatible32="0"
VersionCompatible="0"
MajorVer=1
MinorVer=0
RevisionVer=0
AutoIncrementVer=0
ServerSupportFiles=0
VersionCompanyName=""

VERSION 4.00
Begin VB.Form ASCDEMO
Caption = "VEGA"
ASCII DEMO"
ClientHeight = 7095
ClientLeft = 60
ClientTop = 345
ClientWidth = 9480
Height = 7500
Left = 0
LinkTopic
"Form2"
ScaleHeight = 473
ScaleMode = 3
' Pixel
ScaleWidth = 632
Top = 0
Width = 9600
Begin VB.ListBox List1
Height =
6105
Left =
150
TabIndex = 2
Top =
270
Width =
8985
End
Begin VB.Timer Timer
Enabled = 0
' False
Interval =
100
Left =
720
Top =
6510
End
Begin VB.CommandButton
Caption = "&Start"
Default = -1
' True
Height =
405
Left =
4350
TabIndex = 0
Tag =
"0"
Top =
6570
Width =
1425
End
Begin VB.Shape Led
FillColor =
&H0000FF00&
FillStyle = 0
' Solid
Height =
165
Left =
390
Top =
6570
Width =
135
End
Begin MSCOMM32Lib.MSComm
MSComm
Left =
1200
Top =
6510
_ExtentX =
1005
_ExtentY =

```

```

1 0 0 5                               Next i
      _Version                         =           ' Fehlerzaehler
3 2 7 6 8 0                           initialisieren
      DTREnable                         =           0           InAction = 0
' False                               ' Bereich einstellen
      InBufferSize                       =           StartIndex = 1
5 1 2                                   LenIndex = 30
      InputLen                           =           ' Werte anzeigen
2 0 0                                   DisplayValues
      OutBufferSize                       =           End Sub

1 0 0
      RThreshold                         =           1           Private Sub
      SThreshold                         =           1           Form_Unload(Cancel As Integer)
      EOFEnable                          =           -1          ' Timer stoppen
' True                                  ' Timer.Enabled = False
      End                                 ' Serielle Schnittstelle
End                                     schliessen.
Attribute VB_Name =                   ' If MSComm.PortOpen =
"ASCDEMO"                              True Then
Attribute VB_Creatable =               True Then           MSComm.PortOpen =
False                                   False
Attribute VB_Exposed =                 False
'-----
'           ASCDEMO.FRM
'           Copyright (c) 1999 VEGA
'           by Gros Thoms
'-----
Option Explicit
' Speicher fuer den Empfang
Dim ReceiveBuffer As String
' Fehlerzaehler
Dim InAction As Integer

' Speicher fuer die Werte
and den Status
Dim Status(255) As Integer
Dim DCS(255) As Long

' Start and Ende
Dim StartIndex As Integer
Dim LenIndex As Integer

Private Sub Ende_Click()
' Programm beenden
Unload Me
End Sub

Private Sub Form_Load()
Dim i As Integer
' Speicher initialisieren
For i = 1 To 255
Status(i) = False
DCS(i) = 0

```

```

        ' Daten lesen.
        Call
DecodeFrame (MSComm.Input)
        Loop
    End If
End Sub

Private Sub Run_Click()
    ' ? Start or Stop
    If Run.Tag = "0" Then
        ' ? Schnittstelle
geoeffnet
        If MSComm.PortOpen =
True Then
            ' -> schliessen
            MSComm.PortOpen =
False
        End If
        ' COM1 einsetzen.
        MSComm.CommPort = 1
        ' 9600 Baud, keine
Paritaet, 8 Datenbits and 1
Stopbit
        MSComm.Settings =
"9600,N,8,1"
        ' Schnittstelle
oeffnen.
        MSComm.PortOpen =
True
        ' Timer starten
        Timer.Enabled = True
        If MSComm.PortOpen
Then
            ' Button
umschalten
            Run.Caption =
"&Stop"
            Run.Tag = "1"
        End If
    Else
        ' ? Schnittstelle
geoeffnet
        If MSComm.PortOpen =
True Then
            ' -> schliessen
            MSComm.PortOpen =
False
        End If
        ' Timer ausschalten
        Timer.Enabled =
False
    End If
End Sub

        ' Button umschalten
        Run.Caption =
"&Start"
        Run.Tag = "0"
    End If
End Sub

Private Sub Timer_Timer()
    If InAction = 0 Then
        ' Speicher loeschen
        ReceiveBuffer = ""
        ' Status loeschen
        ClearValues
        ' Ausgabe der
Anfrage
        MSComm.Output = "%"
+ Format(StartIndex, "000")
+ "L" + Format$(LenIndex,
"000") + Chr$(13)
        Else
            ' Fehlerzeahler
benutzen
            InAction = InAction
- 1
            ' ? Grenze erreicht
            If InAction = 0 Then
                ' Werte anzeigen
                DisplayValues
            End If
        End If
    End Sub

Private Sub DecodeFrame(Rec
As String)
    Dim idx As Integer
    Dim Value As Long
    Dim PlsString As String
    Dim SingleValue As String
    Dim p As Integer
    ' Alle characters
auf sammeln
    ReceiveBuffer =
ReceiveBuffer + Rec
        ' Schon 1 Wert empfangen
        p = InStr(ReceiveBuffer,
Chr$(13))
        If p > 0 Then
            ' -> Einzelnen Wert
ausschneiden
            SingleValue =
Left$(ReceiveBuffer, p -
1)
            ReceiveBuffer =
Mid$(ReceiveBuffer, p +
1)
        Else
            SingleValue = ""
        End If
        If Len(SingleValue) > 9
Then
            ' Frame pruefen
            =001#FAULTCR

```

**Supplement A**

Complete overview on the process image of the measured values in VEGACOM 557:

Enquiry to VEGACOM 557	Assignment VEGAMET (switch 2.1=0N)	Assignment DCS numbers (switch 2.2 = OFF)
%001	VEGAMET 1,DCS1	reserve
%002	VEGAMET 2,DCS1	reserve
%003	VEGAMET 3,DCS1	reserve
%004	VEGAMET 4,DCS1	reserve
%005	VEGAMET 5,DCS1	reserve
%006	VEGAMET 6,DCS1	reserve
%007	VEGAMET 7,DCS1	reserve
%008	VEGAMET 8,DCS1	reserve
%009	VEGAMET 9,DCS1	reserve
%010	VEGAMET 10,DCS1	reserve
%011	VEGAMET 11,DCS1	reserve
%012	VEGAMET 12,DCS1	reserve
%013	VEGAMET 13,DCS1	reserve
%014	VEGAMET 14,DCS1	reserve
%015	VEGAMET 15,DCS1	reserve
%016	reserve	reserve
%017	VEGAMET 1,DCS2	VEGAMET 1,DCS1
%018	VEGAMET 2,DCS2	VEGAMET 1,DCS2
%019	VEGAMET 3,DCS2	VEGAMET 1,DCS3
%020	VEGAMET 4,DCS2	VEGAMET 1,DCS4
%021	VEGAMET 5,DCS2	VEGAMET 1,DCS5
%022	VEGAMET 6,DCS2	VEGAMET 1,DCS6
%023	VEGAMET 7,DCS2	VEGAMET 1,DCS7
%024	VEGAMET 8,DCS2	reserve
%025	VEGAMET 9,DCS2	reserve
%026	VEGAMET 10,DCS2	reserve
%027	VEGAMET 11,DCS2	reserve
%028	VEGAMET 12,DCS2	reserve
%029	VEGAMET 13,DCS2	reserve
%030	VEGAMET 14,DCS2	reserve
%031	VEGAMET 15,DCS2	reserve
%032	reserve	reserve
%033	VEGAMET 1,DCS3	VEGAMET 2,DCS1
%034	VEGAMET 2,DCS3	VEGAMET 2,DCS2
%035	VEGAMET 3,DCS3	VEGAMET 2,DCS3
%036	VEGAMET 4,DCS3	VEGAMET 2,DCS4
%037	VEGAMET 5,DCS3	VEGAMET 2,DCS5
%038	VEGAMET 6,DCS3	VEGAMET 2,DCS6
%039	VEGAMET 7,DCS3	VEGAMET 2,DCS7
%040	VEGAMET 8,DCS3	reserve
%041	VEGAMET 9,DCS3	reserve
%042	VEGAMET 10,DCS3	reserve
%043	VEGAMET 11,DCS3	reserve
%044	VEGAMET 12,DCS3	reserve
%045	VEGAMET 13,DCS3	reserve

Enquiry to VEGACOM 557	Assignment VEGAMET (switch 2.1=0N)	Assignment DCS numbers (switch 2.2 = OFF)
%046	VEGAMET 14,DCS3	reserve
%047	VEGAMET 15,DCS3	reserve
%048	reserve	reserve
%049	VEGAMET 1,DCS4	VEGAMET 3,DCS1
%050	VEGAMET 2,DCS4	VEGAMET 3,DCS2
%051	VEGAMET 3,DCS4	VEGAMET 3,DCS3
%052	VEGAMET 4,DCS4	VEGAMET 3,DCS4
%053	VEGAMET 5,DCS4	VEGAMET 3,DCS5
%054	VEGAMET 6,DCS4	VEGAMET 3,DCS6
%055	VEGAMET 7,DCS4	VEGAMET 3,DCS7
%056	VEGAMET 8,DCS4	reserve
%057	VEGAMET 9,DCS4	reserve
%058	VEGAMET 10,DCS4	reserve
%059	VEGAMET 11,DCS4	reserve
%060	VEGAMET 12,DCS4	reserve
%061	VEGAMET 13,DCS4	reserve
%062	VEGAMET 14,DCS4	reserve
%063	VEGAMET 15,DCS4	reserve
%064	reserve	reserve
%065	VEGAMET 1,DCS5	VEGAMET 4,DCS1
%066	VEGAMET 2,DCS5	VEGAMET 4,DCS2
%067	VEGAMET 3,DCS5	VEGAMET 4,DCS3
%068	VEGAMET 4,DCS5	VEGAMET 4,DCS4
%069	VEGAMET 5,DCS5	VEGAMET 4,DCS5
%070	VEGAMET 6,DCS5	VEGAMET 4,DCS6
%071	VEGAMET 7,DCS5	VEGAMET 4,DCS7
%072	VEGAMET 8,DCS5	reserve
%073	VEGAMET 9,DCS5	reserve
%074	VEGAMET 10,DCS5	reserve
%075	VEGAMET 11,DCS5	reserve
%076	VEGAMET 12,DCS5	reserve
%077	VEGAMET 13,DCS5	reserve
%078	VEGAMET 14,DCS5	reserve
%079	VEGAMET 15,DCS5	reserve
%080	reserve	reserve
%081	VEGAMET 1,DCS6	VEGAMET 5,DCS1
%082	VEGAMET 2,DCS6	VEGAMET 5,DCS2
%083	VEGAMET 3,DCS6	VEGAMET 5,DCS3
%084	VEGAMET 4,DCS6	VEGAMET 5,DCS4
%085	VEGAMET 5,DCS6	VEGAMET 5,DCS5
%086	VEGAMET 6,DCS6	VEGAMET 5,DCS6
%087	VEGAMET 7,DCS6	VEGAMET 5,DCS7
%088	VEGAMET 8,DCS6	reserve
%089	VEGAMET 9,DCS6	reserve
%090	VEGAMET 10,DCS6	reserve
%091	VEGAMET 11,DCS6	reserve
%092	VEGAMET 12,DCS6	reserve
%093	VEGAMET 13,DCS6	reserve
%094	VEGAMET 14,DCS6	reserve
%095	VEGAMET 15,DCS6	reserve
%096	reserve	reserve

Enquiry to  
VEGACOM 557

Assignment VEGAMET  
(switch 2.1=0N)

Assignment DCS numbers  
(switch 2.2 = OFF)

%097	VEGAMET 1,DCS7	VEGAMET 6,DCS1
%098	VEGAMET 2,DCS7	VEGAMET 6,DCS2
%099	VEGAMET 3,DCS7	VEGAMET 6,DCS3
%100	VEGAMET 4,DCS7	VEGAMET 6,DCS4
%101	VEGAMET 5,DCS7	VEGAMET 6,DCS5
%102	VEGAMET 6,DCS7	VEGAMET 6,DCS6
%103	VEGAMET 7,DCS7	VEGAMET 6,DCS7
%104	VEGAMET 8,DCS7	reserve
%105	VEGAMET 9,DCS7	reserve
%106	VEGAMET 10,DCS7	reserve
%107	VEGAMET 11,DCS7	reserve
%108	VEGAMET 12,DCS7	reserve
%109	VEGAMET 13,DCS7	reserve
%110	VEGAMET 14,DCS7	reserve
%111	VEGAMET 15,DCS7	reserve
%112	reserve	reserve
%113	reserve	VEGAMET 7,DCS1
%114	reserve	VEGAMET 7,DCS2
%115	reserve	VEGAMET 7,DCS3
%116	reserve	VEGAMET 7,DCS4
%117	reserve	VEGAMET 7,DCS5
%118	reserve	VEGAMET 7,DCS6
%119	reserve	VEGAMET 7,DCS7
%120	reserve	reserve
%121	reserve	reserve
%122	reserve	reserve
%123	reserve	reserve
%124	reserve	reserve
%125	reserve	reserve
%126	reserve	reserve
%127	reserve	reserve
%128	reserve	reserve
%129	reserve	VEGAMET 8,DCS1
%130	reserve	VEGAMET 8,DCS2
%131	reserve	VEGAMET 8,DCS3
%132	reserve	VEGAMET 8,DCS4
%133	reserve	VEGAMET 8,DCS5
%134	reserve	VEGAMET 8,DCS6
%135	reserve	VEGAMET 8,DCS7
%136	reserve	reserve
%137	reserve	reserve
%138	reserve	reserve
%139	reserve	reserve
%140	reserve	reserve
%141	reserve	reserve
%142	reserve	reserve
%143	reserve	reserve
%144	reserve	reserve

Enquiry to VEGACOM 557	Assignment VEGAMET (switch 2.1=0N)	Assignment DCS numbers (switch 2.2 = OFF)
%145	reserve	VEGAMET 9,DCS1
%146	reserve	VEGAMET 9,DCS2
%147	reserve	VEGAMET 9,DCS3
%148	reserve	VEGAMET 9,DCS4
%149	reserve	VEGAMET 9,DCS5
%150	reserve	VEGAMET 9,DCS6
%151	reserve	VEGAMET 9,DCS7
%152	reserve	reserve
%153	reserve	reserve
%154	reserve	reserve
%155	reserve	reserve
%156	reserve	reserve
%157	reserve	reserve
%158	reserve	reserve
%159	reserve	reserve
%160	reserve	reserve
%161	reserve	VEGAMET 10,DCS1
%162	reserve	VEGAMET 10,DCS2
%163	reserve	VEGAMET 10,DCS3
%164	reserve	VEGAMET 10,DCS4
%165	reserve	VEGAMET 10,DCS5
%166	reserve	VEGAMET 10,DCS6
%167	reserve	VEGAMET 10,DCS7
%168	reserve	reserve
%169	reserve	reserve
%170	reserve	reserve
%171	reserve	reserve
%172	reserve	reserve
%173	reserve	reserve
%174	reserve	reserve
%175	reserve	reserve
%176	reserve	reserve
%177	reserve	VEGAMET 11,DCS1
%178	reserve	VEGAMET 11,DCS2
%179	reserve	VEGAMET 11,DCS3
%180	reserve	VEGAMET 11,DCS4
%181	reserve	VEGAMET 11,DCS5
%182	reserve	VEGAMET 11,DCS6
%183	reserve	VEGAMET 11,DCS7
%184	reserve	reserve
%185	reserve	reserve
%186	reserve	reserve
%187	reserve	reserve
%188	reserve	reserve
%189	reserve	reserve
%190	reserve	reserve
%191	reserve	reserve
%192	reserve	reserve

Enquiry to  
VEGACOM 557

Assignment VEGAMET  
(switch 2.1=0N)

Assignment DCS numbers  
(switch 2.2 = OFF)

%193	reserve	VEGAMET 12,DCS1
%194	reserve	VEGAMET 12,DCS2
%195	reserve	VEGAMET 12,DCS3
%196	reserve	VEGAMET 12,DCS4
%197	reserve	VEGAMET 12,DCS5
%198	reserve	VEGAMET 12,DCS6
%199	reserve	VEGAMET 12,DCS7
%200	reserve	reserve
%201	reserve	reserve
%202	reserve	reserve
%203	reserve	reserve
%204	reserve	reserve
%205	reserve	reserve
%206	reserve	reserve
%207	reserve	reserve
%208	reserve	reserve
%209	reserve	VEGAMET 13,DCS1
%210	reserve	VEGAMET 13,DCS2
%211	reserve	VEGAMET 13,DCS3
%212	reserve	VEGAMET 13,DCS4
%213	reserve	VEGAMET 13,DCS5
%214	reserve	VEGAMET 13,DCS6
%215	reserve	VEGAMET 13,DCS7
%216	reserve	reserve
%217	reserve	reserve
%218	reserve	reserve
%219	reserve	reserve
%220	reserve	reserve
%221	reserve	reserve
%222	reserve	reserve
%223	reserve	reserve
%224	reserve	reserve
%225	reserve	VEGAMET 14,DCS1
%226	reserve	VEGAMET 14,DCS2
%227	reserve	VEGAMET 14,DCS3
%228	reserve	VEGAMET 14,DCS4
%229	reserve	VEGAMET 14,DCS5
%230	reserve	VEGAMET 14,DCS6
%231	reserve	VEGAMET 14,DCS7
%232	reserve	reserve
%233	reserve	reserve
%234	reserve	reserve
%235	reserve	reserve
%236	reserve	reserve
%237	reserve	reserve
%238	reserve	reserve
%239	reserve	reserve
%240	reserve	reserve

---

Enquiry to VEGACOM 557	Assignment VEGAMET (switch 2.1=0N)	Assignment DCS numbers (switch 2.2 = OFF)
%241	reserve	VEGAMET 15,DCS1
%242	reserve	VEGAMET 15,DCS2
%243	reserve	VEGAMET 15,DCS3
%244	reserve	VEGAMET 15,DCS4
%245	reserve	VEGAMET 15,DCS5
%246	reserve	VEGAMET 15,DCS6
%247	reserve	VEGAMET 15,DCS7
%248	reserve	reserve
%249	reserve	reserve
%250	reserve	reserve
%251	reserve	reserve
%252	reserve	reserve
%253	reserve	reserve
%254	reserve	reserve
%255	reserve	reserve







**VEGA Grieshaber KG**  
**Am Hohenstein 113**  
**D-77761 Schiltach**  
**Phone (0 78 36) 50 - 0**  
**Fax (0 78 36) 50 - 201**  
**e-mail [info@vega-g.de](mailto:info@vega-g.de)**



The statements on types, application, use and operating conditions of the sensors and processing systems correspond to the latest information at the time of printing.

Technical data subject to alterations