

Operating Instructions

Conductive probe EL 6

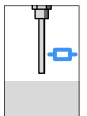

Document ID:
32654



Conductive

Contents

1	About this document	
1.1	Function	3
1.2	Target group	3
1.3	Symbolism used	3
2	For your safety	
2.1	Authorised personnel	4
2.2	Appropriate use	4
2.3	Warning about misuse	4
2.4	General safety instructions	4
2.5	Safety instructions for Ex areas	5
2.6	Environmental instructions	5
3	Product description	
3.1	Configuration	6
3.2	Principle of operation	8
3.3	Operation	8
3.4	Storage and transport	8
4	Mounting	
4.1	General instructions	10
4.2	Mounting instructions	11
5	Connecting to power supply	
5.1	Preparing the connection	12
5.2	Wiring plan	12
6	Set up	
6.1	General information	15
7	Maintenance and fault rectification	
7.1	Maintenance	16
7.2	Rectify malfunctions	16
7.3	Shortening the probe	16
7.4	Instrument repair	16
8	Dismounting	
8.1	Dismounting steps	18
8.2	Removal	18
9	Supplement	
9.1	Technical data	19
9.2	Dimensions	21
9.3	Industrial property rights	22
9.4	Trademark	22

1 About this document

1.1 Function

This operating instructions manual provides all the information you need for mounting, connection and setup as well as important instructions for maintenance and fault rectification. Please read this information before putting the instrument into operation and keep this manual accessible in the immediate vicinity of the device.

1.2 Target group

This operating instructions manual is directed to trained qualified personnel. The contents of this manual should be made available to these personnel and put into practice by them.

1.3 Symbolism used



Information, tip, note

This symbol indicates helpful additional information.



Caution: If this warning is ignored, faults or malfunctions can result.

Warning: If this warning is ignored, injury to persons and/or serious damage to the instrument can result.

Danger: If this warning is ignored, serious injury to persons and/or destruction of the instrument can result.



Ex applications

This symbol indicates special instructions for Ex applications.



List

The dot set in front indicates a list with no implied sequence.



Action

This arrow indicates a single action.



Sequence

Numbers set in front indicate successive steps in a procedure.

2 For your safety

2.1 Authorised personnel

All operations described in this operating instructions manual must be carried out only by trained specialist personnel authorised by the plant operator.

During work on and with the device the required personal protective equipment must always be worn.

2.2 Appropriate use

The EL 6 is a sensor for level detection.

You can find detailed information on the application range in chapter "*Product description*".

Operational reliability is ensured only if the instrument is properly used according to the specifications in the operating instructions manual as well as possible supplementary instructions.

For safety and warranty reasons, any invasive work on the device beyond that described in the operating instructions manual may be carried out only by personnel authorised by the manufacturer. Arbitrary conversions or modifications are explicitly forbidden.

2.3 Warning about misuse

Inappropriate or incorrect use of the instrument can give rise to application-specific hazards, e.g. vessel overfill or damage to system components through incorrect mounting or adjustment.

2.4 General safety instructions

This is a high-tech instrument requiring the strict observance of standard regulations and guidelines. The user must take note of the safety instructions in this operating instructions manual, the country-specific installation standards as well as all prevailing safety regulations and accident prevention rules.

The instrument must only be operated in a technically flawless and reliable condition. The operator is responsible for trouble-free operation of the instrument.

During the entire duration of use, the user is obliged to determine the compliance of the required occupational safety measures with the current valid rules and regulations and also take note of new regulations.

2.5 Safety instructions for Ex areas

Please note the Ex-specific safety information for installation and operation in Ex areas. These safety instructions are part of the operating instructions manual and come with the Ex-approved instruments.

2.6 Environmental instructions

Protection of the environment is one of our most important duties. That is why we have introduced an environment management system with the goal of continuously improving company environmental protection. The environment management system is certified according to DIN EN ISO 14001.

Please help us fulfil this obligation by observing the environmental instructions in this manual:

- Chapter "*Packaging, transport and storage*"
- Chapter "*Disposal*"

3 Product description

3.1 Configuration

Scope of delivery

The scope of delivery encompasses:

- EL 6 point level sensor
- Documentation
 - this operating instructions manual

Constituents

The EL 6 consist of the following components:

- Housing cover
- Housing
- Process fitting with electrode

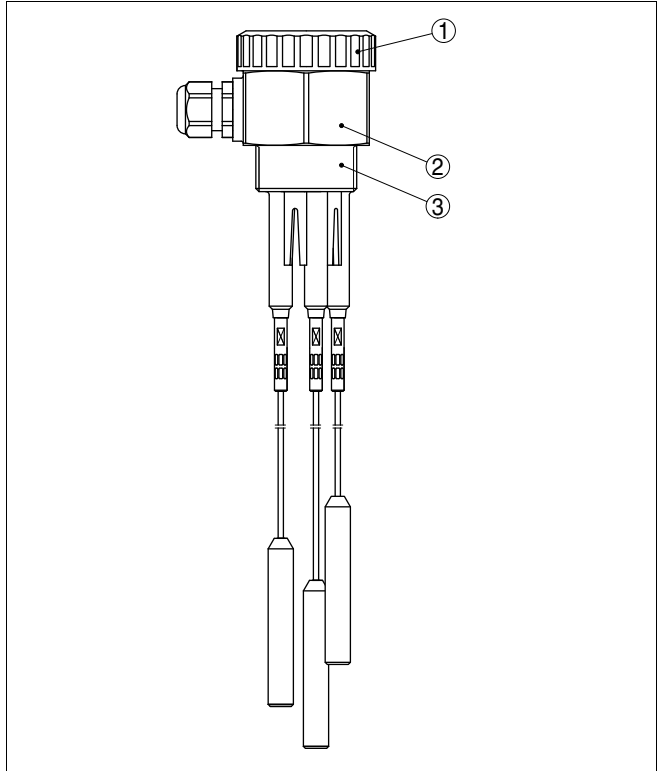

Fig. 1: Conductive multiple cable electrode EL 6

- 1 Housing cover
- 2 Housing
- 3 Process fitting

To create a measuring system you need one conductive probe and a VEGATOR 256C, 532 or 631 signal conditioning instrument.

Type label

The type label contains the most important data for identification and use of the instrument:

- Article number
- Serial number
- Technical data
- Article numbers, documentation

With the serial number, you can access the delivery data of the instrument via www.vega.com, "VEGA Tools" and "serial number search". In addition to the type label outside, you can also find the serial number on the inside of the instrument.

3.2 Principle of operation

Application area	<p>EL 6 is a point level sensor with partly insulated conductive electrode for level detection.</p> <p>EL 6 is very rugged and can be used in all areas of industrial process technology.</p> <p>The level switch can be used in conductive liquids such as e.g. water.</p> <p>Typical applications are overflow and dry run protection.</p> <p>The conductive measuring principle places no special requirements on installation. Hence, many different applications can be equipped with EL 6.</p>
Functional principle	<p>Conductive probes detect the product resistance when their electrodes are covered by the product.</p> <p>The switching signal is determined by the length or mounting position of the respective electrode.</p> <p>A low alternating current flows through the electrodes, is measured for amplitude and phase position by the electronics of the signal conditioning instrument and converted into a switching command.</p>
Voltage supply	<p>EL 6 is operated with an external processing unit. The connected signal conditioning instrument powers EL 6 and provides a switching signal. A connected device can be activated directly with this switching command (e.g. a warning system, a PLC, a pump, etc.).</p> <p>You can find the exact range of the voltage supply in chapter "<i>Technical data</i>" in the operating instructions manual of the signal conditioning instrument.</p>

3.3 Operation

The probe does not have its own electronics. The measurement is carried out via the connected signal conditioning instrument.

3.4 Storage and transport

Packaging	<p>Your instrument was protected by packaging during transport. Its capacity to handle normal loads during transport is assured by a test according to DIN EN 24180.</p> <p>The packaging of standard instruments consists of environment-friendly, recyclable cardboard. For special versions, PE foam or PE foil is also used. Dispose of the packaging material via specialised recycling companies.</p>
Transport	<p>Transport must be carried out under consideration of the notes on the transport packaging. Nonobservance of these instructions can cause damage to the device.</p>

Transport inspection

The delivery must be checked for completeness and possible transit damage immediately at receipt. Ascertained transit damage or concealed defects must be appropriately dealt with.

Storage

Up to the time of installation, the packages must be left closed and stored according to the orientation and storage markings on the outside.

Unless otherwise indicated, the packages must be stored only under the following conditions:

- Not in the open
- Dry and dust free
- Not exposed to corrosive media
- Protected against solar radiation
- Avoiding mechanical shock and vibration

Storage and transport temperature

- Storage and transport temperature see chapter "*Supplement - Technical data - Ambient conditions*"
- Relative humidity 20 ... 85 %

4 Mounting

4.1 General instructions

Switching point

In general the level switch can be mounted in any position. The instrument must be mounted in such a way that the probe is at the height of the requested switching point.

Handling

The probe is provided with a special hexagon for tightening. Due to the hexagon shape, the housing itself can be used to screw the instrument in.

The wrench size is stated in chapter "*Supplement*" under "*Dimensions*".

Moisture

Use the recommended cables (see chapter "*Connecting to power supply*") and tighten the cable gland.

You can give your EL 6 additional protection against moisture penetration by leading the connection cable downward in front of the cable entry. Rain and condensation water can thus drain off. This applies mainly to outdoor mounting as well as installation in areas where high humidity is expected (e.g. through cleaning processes) or on cooled or heated vessels.

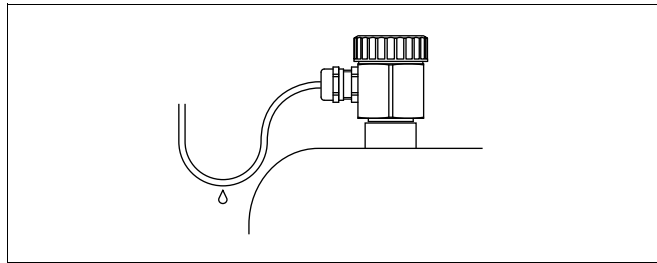

Fig. 2: Measures against moisture penetration

Pressure/Vacuum

The process fitting must be sealed if there is gauge or low pressure in the vessel. Before use, check if the seal material is resistant against the measured product and the process temperature.

The max. permissible pressure is specified in chapter "*Technical data*" or on the type label of the sensor.

4.2 Mounting instructions

Inflowing medium

If EL 6 is mounted in the filling stream, unwanted false measurement signals can be generated. For this reason, mount EL 6 at a position in the vessel where no disturbances, e.g. from filling openings, agitators, etc., can occur.

This applies particularly to instrument versions with a longer probe.

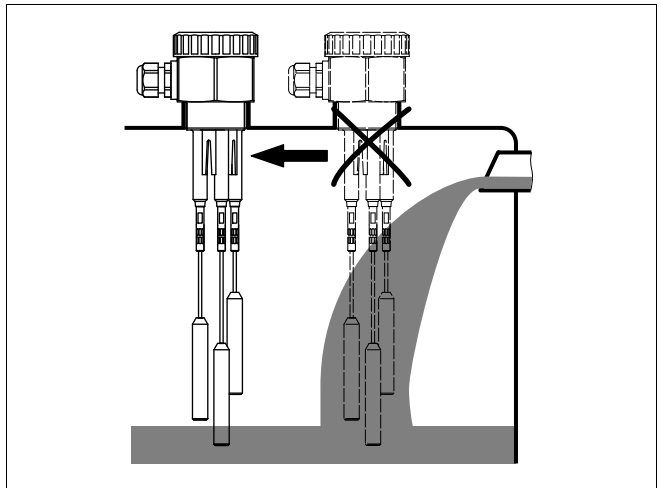

Fig. 3: Inflowing medium

Socket

The probe should protrude into the vessel to avoid buildup. For that reason, avoid using high mounting bosses for screw-in fittings. This applies particularly to use in adhesive products.

Ground connection

Make sure that the mechanical connection of the probe to the vessel is electrically conductive to ensure sufficient grounding.

Use conductive seals, such as those made of copper or lead, etc. Insulating measures, such as covering the thread with Teflon tape, can interrupt the necessary electrical connection with metal vessels. For this reason, ground the probe on the vessel or use a conductive seal material.

5 Connecting to power supply

5.1 Preparing the connection

Note safety instructions

Always keep in mind the following safety instructions:

- Connect only in the complete absence of line voltage

Voltage supply

You can find the electrical connection of EL 6 in the operating instructions manual of the corresponding signal conditioning instrument.

You can find suitable signal conditioning instruments in chapter "*Technical data*".

Connection cable

The instrument is connected with standard two-wire cable without screen. If electromagnetic interference is expected which is above the test values of EN 61326 for industrial areas, screened cable should be used.

Use cable with round cross-section. A cable outer diameter of 5 ... 9 mm (0.2 ... 0.35 in) ensures the seal effect of the cable gland. If you are using cable with a different diameter or cross-section, exchange the seal or use a suitable cable gland.

5.2 Wiring plan

Connection compartment

You can find the electrical connection of EL 6 in the operating instructions manual of the corresponding signal conditioning instrument.

Line monitoring with VEGATOR 631

To realize a line monitoring with a VEGATOR 631 signal conditioning instrument, a resistor of 220 k Ω must be integrated in the connection housing of the probe between terminal 1 and 2.

When a fault message is generated, the switching output is simultaneously activated.

If a fault message is not wanted, a bridge must be provided on the signal conditioning instrument instead of the resistor in the connection housing of the probe.

The line monitoring is thus deactivated and the fault message rendered invalid.

Take note of the operating instructions manual of the signal conditioning instrument.



With Ex versions, this 220 k Ω resistor is already integrated ex factory in the connection housing of the probe. The Ex measuring system (max. and ground connection cable of the probe to the signal conditioning instrument) is generally monitored for line break.

- Terminal 1 = longest cable (ground)

- Terminal 2 = shortest cable (max.)

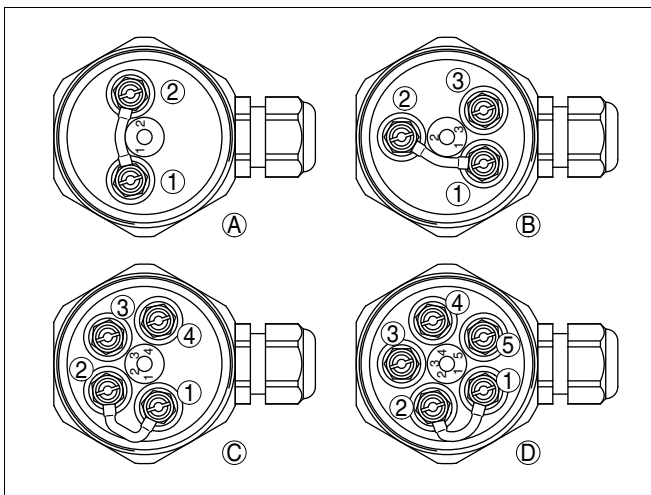

Fig. 4: Connection compartment of the probe - 220 kΩ resistance between terminals 1 and 2

- 1 Connection terminal 1 = longest cable
- 2 Connection terminal 2 = shortest cable
- A Probe with 2 cables
- B Probe with 3 cables
- C Probe with 4 cables
- D Probe with 5 cables

Line monitoring with VEGATOR 632

The line break monitoring or alarm function defines the function of the signal conditioning instrument in case of failure.

To realize line monitoring with a signal conditioning instrument VEGATOR 632, an additional component must be mounted in the connection housing of the probe.

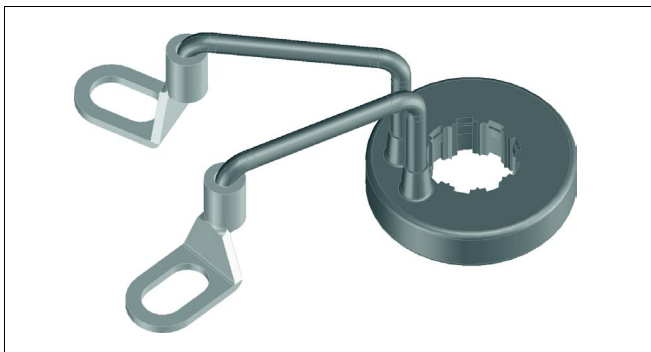

Fig. 5: Component for line break monitoring in conjunction with VEGATOR 632

- 1 Connect the eyelet according to the following illustration.
Make sure that the eyelets have no contact to other metal parts.
- 2 Open one of the other terminals and attach the component.
- 3 Tighten the terminal.

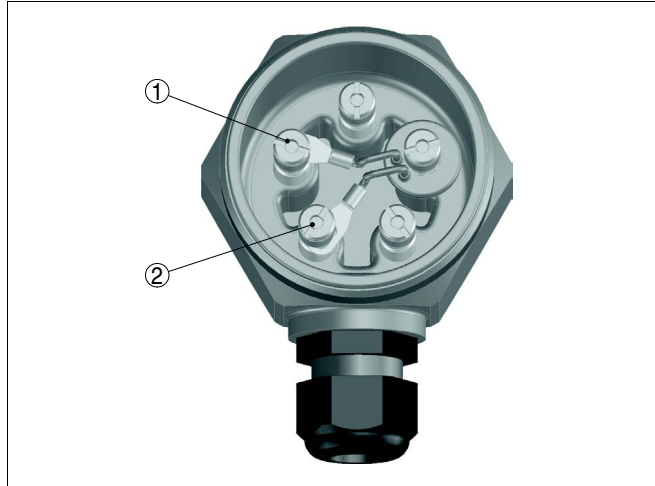

Fig. 6: Mounting of the component for line break monitoring

- 1 Connection to terminal 1 (ground rod = longest rod)
- 2 Connection to terminal 2 (max. rod = shortest rod)
- 3 Component for line break monitoring with VEGATOR 632

If you are using a probe without component for line break monitoring, a fault signal will be triggered.

Keep in mind that in case of a fault signal also the switching output will be activated.

Only failures of channel 1 are monitored.

Take note of the operating instructions manual of the signal conditioning instrument.

6 Set up

6.1 General information

You can find the setup procedure for EL 6 in the operating instructions manual of the corresponding signal conditioning instrument.

7 Maintenance and fault rectification

7.1 Maintenance

When used as directed in normal operation, EL 6 is completely maintenance free.

7.2 Rectify malfunctions

Causes of malfunction

EL 6 offers maximum reliability. Nevertheless, faults can occur during operation. These may be caused by the following, e.g.:

- Sensor
- Process
- Voltage supply
- Signal processing

Fault rectification

You can find information on fault rectification in the operating instructions manual of the corresponding signal conditioning instrument.

24 hour service hotline

However, should these measures not be successful, call the VEGA service hotline in urgent cases under the phone no. **+49 1805 858550**.

The hotline is available to you 7 days a week round-the-clock. Since we offer this service world-wide, the support is only available in the English language. The service is free of charge, only the standard telephone costs will be charged.

7.3 Shortening the probe

The probe can be shortened by any amount.



Note:

Take note when shortening multiple probes that terminal 1 corresponds to the longest probe and terminal 2 to the shortest probe.

7.4 Instrument repair

If a repair is necessary, please proceed as follows:

You can download a return form (23 KB) from our Internet homepage www.vega.com under: "*Downloads - Forms and certificates - Repair form*".

By doing this you help us carry out the repair quickly and without having to call back for needed information.

- Print and fill out one form per instrument
- Clean the instrument and pack it damage-proof

- Attach the completed form and, if need be, also a safety data sheet outside on the packaging
- Please ask the agency serving you for the address of your return shipment. You can find the respective agency on our website www.vega.com under: "*Company - VEGA worldwide*"

8 Dismounting

8.1 Dismounting steps

**Warning:**

Before dismounting, be aware of dangerous process conditions such as e.g. pressure in the vessel, high temperatures, corrosive or toxic products etc.

Take note of chapters "*Mounting*" and "*Connecting to power supply*" and carry out the listed steps in reverse order.

8.2 Removal

The instrument consists of materials which can be recycled by specialised recycling companies. We use recyclable materials and have designed the electronics to be easily separable.

WEEE directive 2002/96/EG

This instrument is not subject to the WEEE directive 2002/96/EG and the respective national laws. Pass the instrument directly on to a specialised recycling company and do not use the municipal collecting points. These may be used only for privately used products according to the WEEE directive.

Correct disposal avoids negative effects to persons and environment and ensures recycling of useful raw materials.

Materials: see chapter "*Technical data*"

If you have no possibility to dispose of the old instrument professionally, please contact us concerning return and disposal.

9 Supplement

9.1 Technical data

General data

Materials 316Ti corresponds to 1.4571, 316L corresponds to 1.4404 or 1.4435

Materials, wetted parts

– Process fitting	PP
– Process seal	Klingsil C-4400
– insulation (partly insulated)	FEP
– Probe (cable FEP partly insulated: ø 2.5 mm/0.098 in)	316Ti

Materials, non-wetted parts

– Housing	PP
– Housing cover	PBT
– Seal between housing and housing cover	NBR
– Cable gland	PA

Process fitting G1½ A (ISO 228 T1)

Weight

– with plastic housing	500 g (17.6 oz)
– Cable weight: ø 2.5 mm (0.098 in)	40 g/m (0.4 oz/ft)

Sensor length (L1 - L5) 0.22 ... 50 m (0.722 ... 164.04 ft)

Insulation length 78 mm (3 in)

Output variable

Suitable signal conditioning instruments VEGATOR 256C, 532, 631

Ambient conditions

Ambient temperature on the housing	-40 ... +80 °C (-40 ... +176 °F)
Storage and transport temperature	-40 ... +80 °C (-40 ... +176 °F)

Process conditions

Process pressure	-1 ... 6 bar/-100 ... 600 kPa (-14.5 ... 87 psig)
Process temperature EL 6 of 316L	-20 ... +100 °C (-4 ... +212 °F)
Conductive of the medium	min. 7.5 µS/cm

Electromechanical data

Cable entry	1 x cable gland M20 x 1.5 (cable: ø 5 ... 9 mm/ 0.2 ... 0.35 in)
-------------	---

Electrical protective measures

Protection rating	IP 66/IP 67
-------------------	-------------

Approvals

Depending on the version, instruments with approvals can have different technical data.

For these instruments, the corresponding approval documents have to be taken into account. These are part of the delivery or can be downloaded under www.vega.com via "VEGA Tools" and "serial number search" as well as via "Downloads" and "Approvals".

9.2 Dimensions

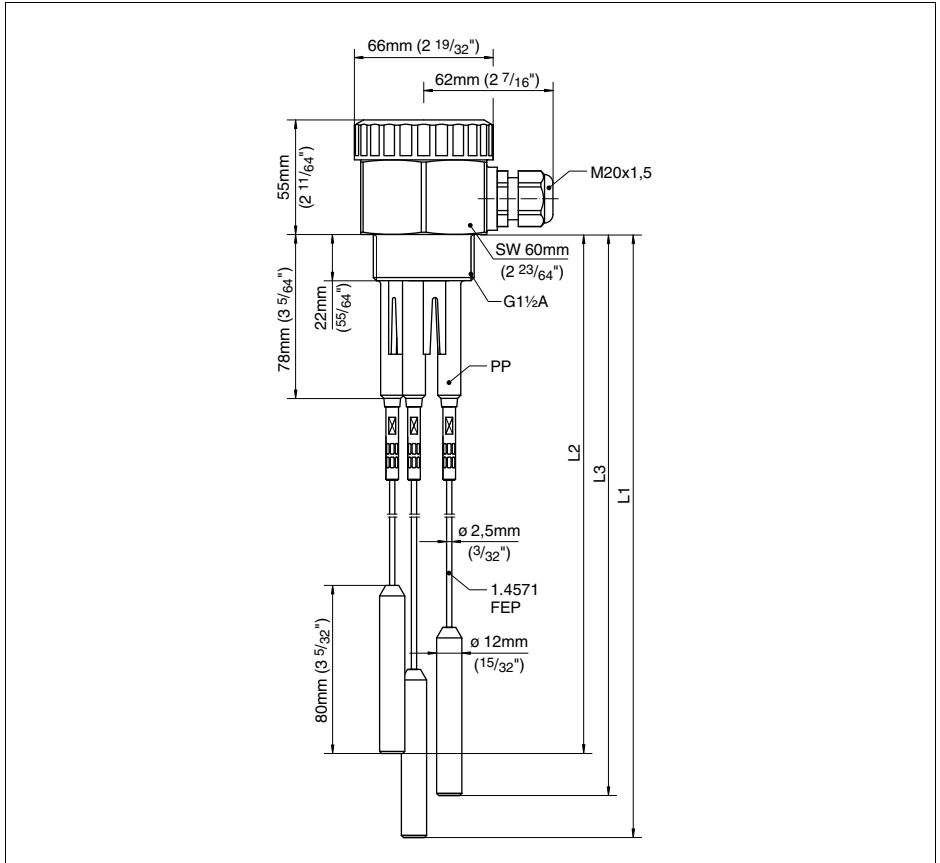

Fig. 7: Conductive multiple cable electrode EL 6

L1 Sensor length, see chapter "Technical data"

L2 Sensor length, see chapter "Technical data"

L3 Sensor length, see chapter "Technical data"

9.3 Industrial property rights

VEGA product lines are global protected by industrial property rights.
Further information see <http://www.vega.com>.
Only in U.S.A.: Further information see patent label at the sensor housing.

VEGA Produktfamilien sind weltweit geschützt durch gewerbliche Schutzrechte.
Nähere Informationen unter <http://www.vega.com>.

Les lignes de produits VEGA sont globalement protégées par des droits de propriété intellectuelle.
Pour plus d'informations, on pourra se référer au site <http://www.vega.com>.

VEGA líneas de productos están protegidas por los derechos en el campo de la propiedad industrial.
Para mayor información revise la pagina web <http://www.vega.com>.

Линии продукции фирмы ВЕГА защищаются по всему миру правами на интеллектуальную собственность.
Дальнейшую информацию смотрите на сайте <http://www.vega.com>.

VEGA系列产品在全球享有知识产权保护。
进一步信息请参见网站<<http://www.vega.com>>。

9.4 Trademark

All the brands as well as trade and company names used are property of their lawful proprietor/originator.



Printing date:

VEGA Grieshaber KG
Am Hohenstein 113
77761 Schiltach
Germany
Phone +49 7836 50-0
Fax +49 7836 50-201
E-mail: info@de.vega.com
www.vega.com



All statements concerning scope of delivery, application, practical use and operating conditions of the sensors and processing systems correspond to the information available at the time of printing.

© VEGA Grieshaber KG, Schiltach/Germany 2010