

VEGA

Operating Instructions

VEGACAP 98

- double relay (DPDT)

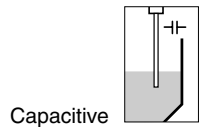

Contents

- 1 About this document**
 - 1.1 Function 5
 - 1.2 Target group 5
 - 1.3 Symbolism used 5

- 2 For your safety**
 - 2.1 Authorised personnel 6
 - 2.2 Appropriate use 6
 - 2.3 Warning about misuse 6
 - 2.4 General safety instructions 6
 - 2.5 Safety approval markings and safety tips 7
 - 2.6 CE conformity 7
 - 2.7 Safety instructions for Ex areas 7
 - 2.8 Environmental instructions 7

- 3 Product description**
 - 3.1 Configuration 8
 - 3.2 Principle of operation 9
 - 3.3 Operation 10
 - 3.4 Storage and transport 11

- 4 Mounting**
 - 4.1 General instructions 12
 - 4.2 Mounting instructions 13

- 5 Connecting to power supply**
 - 5.1 Preparing the connection 14
 - 5.2 Wiring plan, single chamber housing 14

- 6 Set up**
 - 6.1 General 16
 - 6.2 Adjustment elements 16
 - 6.3 Functional chart 19

- 7 Maintenance and fault rectification**
 - 7.1 Maintenance 20
 - 7.2 Remove interferences 20
 - 7.3 Exchange of the electronics module 23
 - 7.4 Instrument repair 23

- 8 Dismounting**
 - 8.1 Dismounting steps 25
 - 8.2 Disposal 25

9 Supplement

9.1	Technical data	26
9.2	Dimensions	29
9.3	Industrial property rights.	30
9.4	Trademark	30

Supplementary documentation



Information:

Supplementary documents appropriate to the ordered version come with the delivery. You can find them listed in chapter "*Product description*".

Instructions manuals for accessories and replacement parts



Tip:

To ensure reliable setup and operation of your VEGACAP 98, we offer accessories and replacement parts. The associated documents are:

- Operating instructions manual "*Oscillator CAP E31R*"

1 About this document

1.1 Function

This operating instructions manual provides all the information you need for mounting, connection and setup as well as important instructions for maintenance and fault rectification. Please read this information before putting the instrument into operation and keep this manual accessible in the immediate vicinity of the device.

1.2 Target group

This operating instructions manual is directed to trained personnel. The contents of this manual should be made available to these personnel and put into practice by them.

1.3 Symbolism used



Information, tip, note

This symbol indicates helpful additional information.



Caution: If this warning is ignored, faults or malfunctions can result.

Warning: If this warning is ignored, injury to persons and/or serious damage to the instrument can result.

Danger: If this warning is ignored, serious injury to persons and/or destruction of the instrument can result.



Ex applications

This symbol indicates special instructions for Ex applications.



List

The dot set in front indicates a list with no implied sequence.



Action

This arrow indicates a single action.



Sequence

Numbers set in front indicate successive steps in a procedure.

2 For your safety

2.1 Authorised personnel

All operations described in this operating instructions manual must be carried out only by trained specialist personnel authorised by the operator.

During work on and with the device the required personal protection equipment must always be worn.

2.2 Appropriate use

VEGACAP 98 is a sensor for level detection.

You can find detailed information on the application range in chapter "*Product description*".

Operational reliability is ensured only if the instrument is properly used according to the specifications in the operating instructions manual as well as possible supplementary instructions.

Due to safety and warranty reasons, any invasive work on the device beyond that described in the operating instructions manual may be carried out only by personnel authorised by the manufacturer. Arbitrary conversions or modifications are explicitly forbidden.

2.3 Warning about misuse

Inappropriate or incorrect use of the instrument can give rise to application-specific hazards, e.g. vessel overfill or damage to system components through incorrect mounting or adjustment.

2.4 General safety instructions

This is a high-tech instrument requiring the strict observance of standard regulations and guidelines. The user must take note of the safety instructions in this operating instructions manual, the country-specific installation standards as well as all prevailing safety regulations and accident prevention rules.

The instrument must only be operated in a technically flawless and reliable condition. The operator is responsible for trouble-free operation of the instrument.

During the entire duration of use, the user is obliged to determine the compliance of the required occupational safety measures with the current valid rules and regulations and also take note of new regulations.

2.5 Safety approval markings and safety tips

The safety approval markings and safety tips on the device must be observed.

2.6 CE conformity

VEGACAP 98 is in CE conformity with EMC (89/336/EWG) and LVD (73/23/EWG).

Conformity has been judged according to the following standards:

- EMC:
 - Emission EN 50081-1: 1992
 - Suceptibility EN 50082-2: 1995
- LVD: EN 61010-1: 1993

2.7 Safety instructions for Ex areas

Please note the Ex-specific safety information for installation and operation in Ex areas. These safety instructions are part of the operating instructions manual and come with the Ex-approved instruments.

2.8 Environmental instructions

Protection of the environment is one of our most important duties. That is why we have introduced an environment management system with the goal of continuously improving company environmental protection. The environment management system is certified according to DIN EN ISO 14001.

Please help us fulfil this obligation by observing the environmental instructions in this manual:

- Chapter "*Packaging, transport and storage*"
- Chapter "*Disposal*"

3 Product description

3.1 Configuration

Scope of delivery

The scope of delivery encompasses:

- VEGACAP 98 level sensor
- Documentation
 - this operating instructions manual
 - if necessary, further documents

Components

VEGACAP 98 consists of the following components:

- Housing cover
- Housing with electronics
- Process fitting with electrode

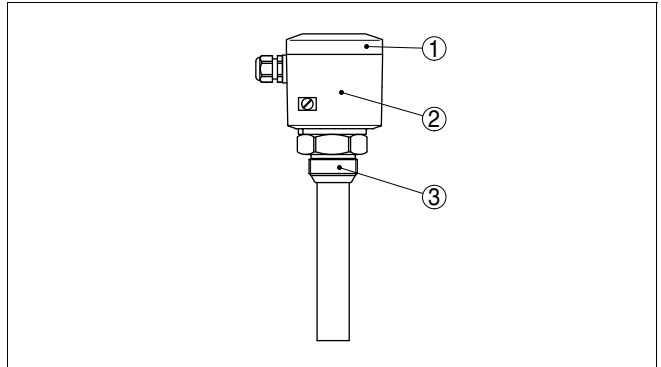

Fig. 1: VEGACAP 98

- 1 Housing cover
- 2 Housing with electronics
- 3 Process fitting

Type label

The type label contains the most important data for identification and use of the instrument:

- Article number
- Serial number
- Technical data
- Article numbers, documentation

With the serial number, it is possible to show the delivery data of the instrument via "www.vega.com", "*VEGA Tools*" and "*serial number search*". In addition to the type label outside on the instrument, the serial number is also available inside the instrument.

3.2 Principle of operation

Area of application

VEGACAP 98 is a level switch with fully insulated, capacitive electrode with screen segment and active tip for level detection.

VEGACAP 98 is very rugged and maintenance-free and can be used in all areas of industrial process technology.

Typical applications are overflow and dry run protection.

Setup of the instrument is very easy because an adjustment is not necessary. This means that changing products with different dielectric values, such as e.g. water and oil or conductive and non-conductive products, do not influence the settings on the instrument and their switching accuracy.

Fully insulated probes with screen segment like VEGACAP 98 are used in conductive, very adhesive liquids as well as in bulk solids.

Due to the mechanical construction with screen segment and the active tip, buildup on the probe is compensated.

The capacitive measuring principle places no special requirements on installation. Hence, many different applications can be equipped with VEGACAP 98.

Due to the construction in PP, the instrument can also be used problem-free in corrosive products.

Functional principle

Probe, measured product and vessel wall form an electrical capacitor. The capacitance is influenced by three main factors.

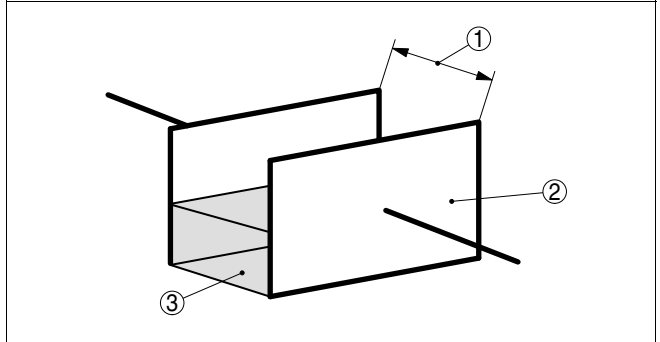

Fig. 2: Functional principle - Plate capacitor

- 1 Distance between the electrode surfaces
- 2 Size of the electrode surfaces
- 3 Type of dielectric between the electrodes

The probe and the vessel wall are the capacitor plates. The measured product is the dielectric. Due to the higher dielectric constant (DK value) of the product compared to air, the capacitance increases as the probe is gradually covered.

The capacitance change is converted by the oscillator into a switching command.

Supply

VEGACAP 98 is a compact instrument, i.e. it can be operated without external evaluation system. The integrated electronics evaluates the level signal and outputs a switching signal. With this switching signal, a connected device can be operated directly (e.g. a warning system, a PLC, a pump etc.).

You can find data on voltage supply in chapter "*Technical data*" in the "*Supplement*".

3.3 Operation

The probe can be adapted to the dielectric value of the product directly on the electronics module.

A switching command can be triggered when the probe is covered or laid bare.

On the electronics module you will find the following indicating and adjustment elements:

- Control lamp for indication of the switching condition
- Potentiometer for switching point adaptation (covered)
- DIL switch for mode adjustment

3.4 Storage and transport

Packaging	<p>Your instrument was protected by packaging during transport. Its capacity to handle normal loads during transport is assured by a test according to DIN EN 24180.</p> <p>The packaging of standard instruments consists of environment-friendly, recyclable cardboard. For special versions, PE foam or PE foil is also used. Dispose of the packaging material via specialised recycling companies.</p>
Transport	<p>Transport must be carried out under consideration of the notes on the transport packaging. Nonobservance of these instructions can cause damage to the device.</p>
Transport inspection	<p>The delivery must be checked for completeness and possible transit damage immediately at receipt. Ascertained transit damage or concealed defects must be appropriately dealt with.</p>
Storage	<p>Up to the time of installation, the packages must be left closed and stored according to the orientation and storage markings on the outside.</p> <p>Unless otherwise indicated, the packages must be stored only under the following conditions:</p> <ul style="list-style-type: none"> ● Not in the open ● Dry and dust free ● Not exposed to corrosive media ● Protected against solar radiation ● Avoiding mechanical shock and vibration
Storage and transport temperature	<ul style="list-style-type: none"> ● Storage and transport temperature see "<i>Supplement - Technical data - Ambient conditions</i>" ● Relative humidity 20 ... 85 %

4 Mounting

4.1 General instructions

- Switching point** In general the level switch can be mounted in any position. The instrument must be mounted in such a way that the probe is at the height of the requested switching point.
- Welding work** Before beginning with the welding work, remove the oscillator out of the sensor. By doing this, you avoid damages on the electrode due to inductive couplings.
- Handling** With threaded versions, the housing must not be used to screw the instrument in! Applying tightening force on the housing can damage its rotational mechanical parts.
- Use the hexagon for screwing in.
- Moisture** Use the recommended cables (see chapter "*Connecting to power supply*") and tighten the cable gland.
- You can give your VEGACAP 98 additional protection against moisture penetration by leading the connection cable downward in front of the cable entry. Rain and condensation water can thus drain off. This applies mainly to outdoor mounting, areas where high humidity is expected (e.g. from cleaning processes) or cooled or heated vessels.

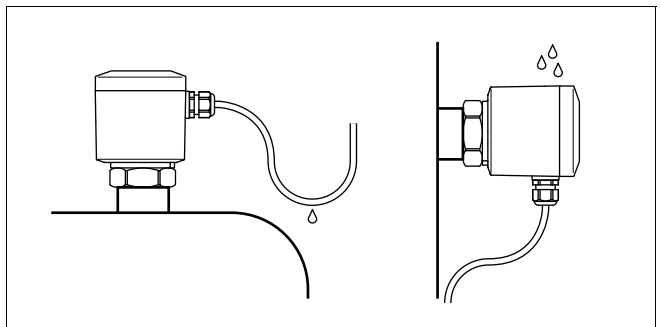

Fig. 3: Measures against moisture penetration

- Pressure/Vacuum** The process fitting must be sealed if there is gauge or low pressure in the vessel. Before use, check if the seal material is resistant against the measured product and the process temperature.
- The max. permissible pressure is stated in chapter "*Technical data*" in the "*Supplement*" or on the type label of the sensor.

4.2 Mounting instructions

Inflowing medium

If VEGACAP 98 is mounted in the filling stream, unwanted erroneous measurements may result. Mount VEGACAP 98 at a location in the vessel where no disturbing influence from e.g. filling openings, agitators, etc. can occur.

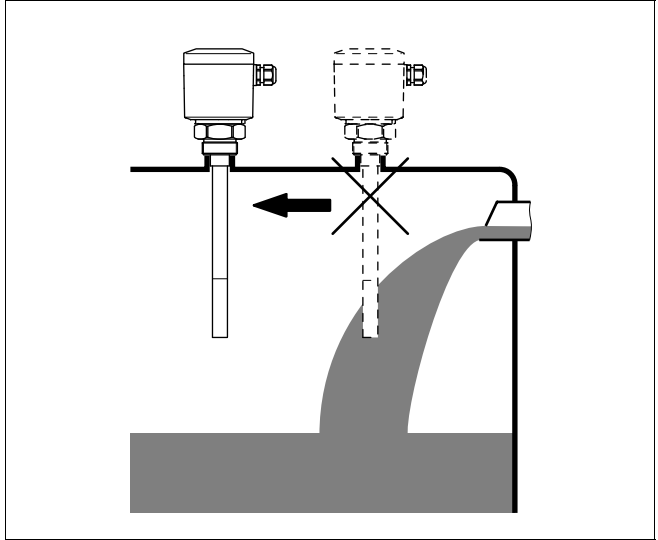

Fig. 4: Inflowing medium

5 Connecting to power supply

5.1 Preparing the connection

Note safety instructions

Always keep in mind the following safety instructions:

- Connect only in the complete absence of line voltage

Select power supply

Connect the power supply according to the following diagrams. Oscillator CAP E31R is designed in protection class 1. To maintain this protection class, it is absolutely necessary that the ground conductor be connected to the internal ground terminal. Take note of the general installation regulations. As a rule, connect VEGACAP 98 to vessel ground (PA), or in case of plastic vessels, to the next ground potential. On the side of the housing there is a ground terminal between the cable entries. This connection serves to drain off electrostatic charges.

You can find data on voltage supply in chapter "*Technical data*" in the "*Supplement*".

Selecting connection cable

VEGACAP 98 is connected with standard cable with round cross section. An outer cable diameter of 5 ... 9 mm (0.2 ... 0.35 in) ensures the seal effect of the cable gland.

If cable with a different diameter or wire cross section is used, exchange the seal or use an appropriate cable connection.



Note:

When placing the housing cover, make sure that the inspection glass is above the signal lamp of the oscillator.

5.2 Wiring plan, single chamber housing

Wiring plan

We recommend connecting VEGACAP 98 in such a way that the switching circuit is open when there is a level signal, line break or failure (safe condition).

The relays are always shown in non-operative condition.

The two relays (DPDT) work synchronously. Hence it is possible to control also e.g. a horn and a magnet valve.

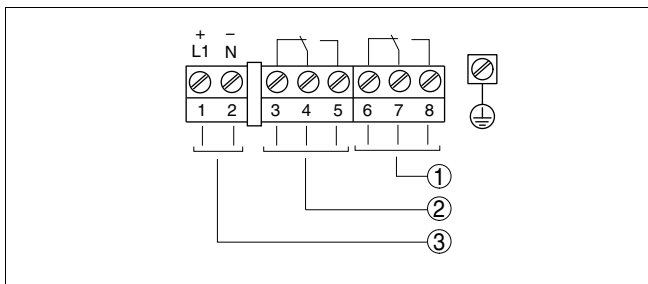

Fig. 5: Wiring plan

1 Relay output

2 Relay output

3 Voltage supply

6 Set up

6.1 General

The numbers in brackets refer to the following illustrations.

Function/Configuration

On the electronics module you will find the following indicating and adjustment elements:

- Potentiometer for switching point adaptation
- DIL switch for mode adjustment - A/B
- Control lamp



Note:

As a rule, always set the mode with the mode switch (5) before starting setup VEGACAP 98. The switching output will change if you set the mode switch (5) afterwards. This could possibly trigger other connected instruments or devices.

6.2 Adjustment elements

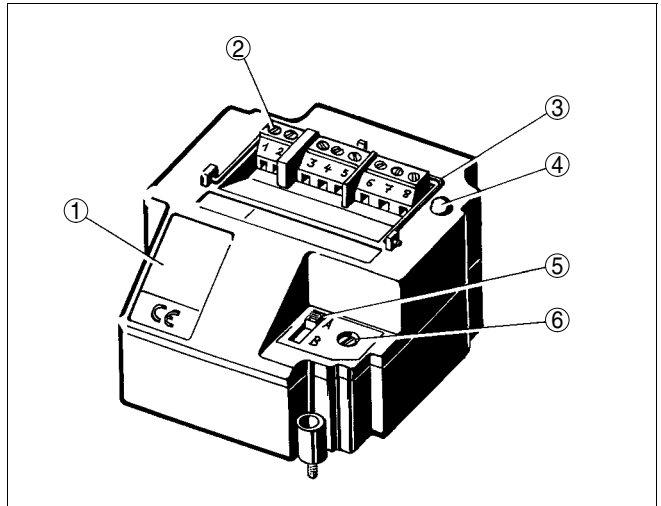

Fig. 6: Oscillator with relay output

- 1 Type label
- 2 Connection terminals
- 3 Tensile proving ring
- 4 Control lamp
- 5 DIL switch for mode adjustment
- 6 Potentiometer for switching point adaptation

The switching status of the electronics can be checked with closed housing (only plastic housing), see "*Function chart*".



Note:

When placing the housing cover, make sure that the inspection glass is above the signal lamp (LED) of the oscillator.

To adjust VEGACAP 98, loosen first of all the four screws on the upper side of the instrument with a screwdriver and remove the housing cover.

Switching point adaptation (6) You can adapt the switching point to the solid with the potentiometer.

The electronics is adjustment free and an adaption is only necessary in exceptions. See "*Exceptions*".

Mode adjustment (5)

With the mode switch you can change the switching condition of the relay. You can set the required mode (A - max. detection or overflow protection, B - min. detection or dry run protection).

We recommend connecting according to the quiescent current principle (relay contact deenergizes when the switching point is reached), because the relay always takes on the same (safe) condition if a failure is detected or in case of mains failure.

Signal lamp (4)

Control lamp for indication of the switching condition.

- Control lamp on = Relay deenergised

Switching point adjustment

The measuring system is immediately ready for operation.

The switching point must no longer be set with VEGACAP 98.

The probe has an active tip and a screen segment. Thanks to the screen segment, the so called standing capacitance, caused by the vessel after installation of the probe, is mainly compensated.

As a default setting, the oscillator is adjusted to the basic capacitance of the probe. The relay output switching when the active tip is covered (active tip: 90 mm / 3.5 in) of the electrode.

Changing dielectric values of the products, such as e.g. caused in mixing vessels are no problem for the switching accuracy within the active pin. The selection of the electrode length is hence very important because the length of the electrode determines the switching point. This switching point cannot be shifted on the electrode.

Exceptions

In exceptions, e.g. in pipelines or if the probe is mounted very close to the vessel wall, it can happen that the probe signals already overflowing (covering) in uncovered condition.

In this case, the switching point must be re-adjusted.

For adjustment, the vessel must not be filled and the switching point adjustment is also possible in dismantled condition.

A fresh adjustment is necessary in the following cases:

- in narrow space installation conditions with high standing capacitance (e.g. in tubes etc.)
- after exchange of the oscillator

Fresh adjustment

Proceed as follows for a fresh adjustment:

- 1 Make sure that the probe is uncovered.
- 2 Pierce the cover of the potentiometer (6) with a screw-driver.
- 3 Turn the below potentiometer (6) first of all anticlockwise (max. 20 turns) until the control lamp signals "covered".
 Mode A (overflow protection) = control lamp lights
 Mode B (dry run protection) = control lamp extinguishes
 If this condition is already reached, you can continue with the next step.
- 4 Turn the potentiometer (6) very slowly (due to the damping) clockwise until the control lamp signals "uncovered".
 Mode A (overflow protection) = control lamp extinguishes
 Mode B (dry run protection) = control lamp lights
- 5 Turn the potentiometer (6) clockwise according to the following chart.
- 6 The probe is now ready for operation.

Sensitivity

	Standard	very sensitive
additional turns	DK value >2 = 2 turns	DK value >1.5 = 1 turn

Tab. 1: Number of additional turns for the potentiometer (6)



Note:

With the measurement of products with very low dielectric values, the number of turns can be reduced up to 1 according to the chart.

















This setting is too sensitive with conductive, adhesive products.

**Note:**

When placing the housing cover, make sure that the inspection glass is above the signal lamp of the oscillator.

6.3 Functional chart

The following chart provides an overview of the switching conditions depending on the adjusted mode and level.

	Level	Switching status	Control lamp
Mode A Overfill protection		 Relay energized	
Mode A Overfill protection		 Relay deenergized	
Mode B Dry run protection		 Relay energized	
Mode B Dry run protection		 Relay deenergized	
Failure of the supply voltage (mode A/B)	any	 Relay deenergized	
Failure	any	 Relay deenergized	

7 Maintenance and fault rectification

7.1 Maintenance

When used as directed in normal operation, VEGACAP 98 is completely maintenance free.

7.2 Remove interferences

Reaction in case of failures	The operator of the system is responsible for taken suitable measures to remove interferences.
Fault rectification	The first measure to be taken is to check the output signal. In many cases, the causes can be determined this way and the faults rectified.
24 hour service hotline	<p>However, if these measures are not successful, call the VEGA service hotline in urgent cases under the phone no. +49 1805 858550.</p> <p>The hotline is available to you 7 days a week round-the-clock. Since we offer this service world-wide, the support is only available in the English language. The service is free of charge, only the standard telephone costs will be charged.</p>
Checking the switching signal	<ul style="list-style-type: none">? VEGACAP 98 signals "covered" when the vibrating element is not submerged (overflow protection)? VEGACAP 98 signals "uncovered" when the vibrating element is submerged (dry run protection)<ul style="list-style-type: none">● Wrong mode selected<ul style="list-style-type: none">→ Set the correct mode on the mode switch (A - overflow protection, B - dry run protection). Wiring should be carried out according to the quiescent current principle.● Supply voltage too low<ul style="list-style-type: none">→ Check the power supply● Electronics defective<ul style="list-style-type: none">→ Press the mode switch (A/B). If the instrument then changes the mode, the instrument may be mechanically damaged. Should the switching function in the correct mode still be faulty, return the probe for repair.→ Push the mode switch. If the probe then does not change the mode, the oscillator may be defective. Exchange the oscillator.

- Shortcircuit in the probe, e.g. because of moisture in the housing
- Remove the oscillator and check the resistance between the marked plug connections according to the following illustration.

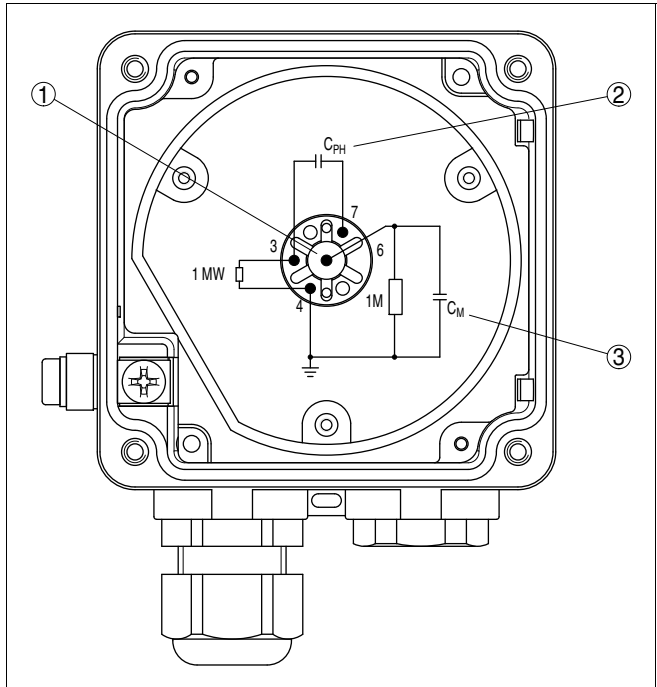

Fig. 23: Check the resistance in the probe

- 1 Middle pin
- 2 Variable capacitor (phase)
- 3 Capacitor

Measure the resistance values between the following contacts with an ohmmeter (range MOhm).

Contact 4 against middle pin (1)

The resistor must be 1 MOhm.

If the resistor is lower, this means moisture in the housing or a fault in the electrode insulation. A possible reason could be also a non-insulated electrode which is used in a conductive (humid) medium.

If the resistor is higher or if the connection is interrupted, the reason is mostly a contact error in the adapter plate or a defective resistor due to strong electrostatic arking.

In both cases, the probe must be repaired in our premises.

Contact 4 against vessel

The electrical connection between contact 4 and metal vessel (not the mounting boss or probe flange) should be good. Measure the resistance value between contact 4 and vessel with an ohmmeter (range very small).

- Shortcircuit (0 ... 3 Ohm) - optimum connection
- Resistor >3 Ohm - bad connection

If the resistance value is >3 Ohm, this can be due to corrosion on the thread or flange or the thread was covered e.g. with teflon tape.

Check the connection to the vessel. If there is no connection, you can connect a cable from the outer ground terminal to the vessel.

Keep in mind that coated flanges must always be connected via the ground terminal to the vessel.

Contact 7 against middle pin (1)

The resistor must be infinite (>10 MOhm)

If the resistor is lower, then moisture can be penetrated or the compensation capacitor or variable capacitor (phase) is defective.

Contact 3 against 4

The resistor must be 1 MOhm.

In case of lower values, the electrode insulation is defective or moisture is penetrated into the housing.

In case of higher values, there is a contacting error in the adapter plate or the resistor is defective.

No fault

If you cannot find a fault in the probe, then exchange the oscillator by a similar replacement electronics (if available).

If the fault is eliminated after inserting the new oscillator, then you have to carry out a fresh adjustment with the new oscillator because oscillators have certain manufacturing tolerances.

If the fault still exists or if no replacement oscillator is available, then you have to return the probe for repair.

Reaction after fault rectification

Depending on the failure reason and measures taken, the steps described in chapter "Set up" must be carried out again, if necessary.

7.3 Exchange of the electronics module

If it is necessary to exchange the oscillator, you should use an oscillator type CAP E31R

Proceed as follows:

- 1 Switch off power supply
 - 2 Loosen the four screws of the housing cover with a Phillips screwdriver.
 - 3 Remove the housing cover
 - 4 Loosen the screws of the terminals with a Allen wrench.
 - 5 Pull the connection cables out of the terminals.
 - 6 Loosen the two screws with a Phillips screwdriver.
 - 7 Open the tensile ring on the old oscillator and pull out the old oscillator.
 - 8 Compare the new oscillator with the old one. The type label of the oscillator must correspond to that of the old oscillator.
 - 9 Insert the new oscillator.
 - 10 Screw in and tighten the two screws with a Phillips screwdriver.
 - 11 Lead the connection cable through the cable gland.
 - 12 Insert the wire ends into the open terminals according to the wiring plan and tighten them.
 - 13 Check the hold of the wires in the terminals by lightly pulling on them.
 - 14 Turn the cable gland right back and check the tightness. The seal ring must completely encircle the cable.
 - 15 Carry out a fresh adjustment. See chapter "Set up, new adjustment".
 - 16 Screw the housing cover on
- The electronics exchange is now finished.

7.4 Instrument repair

If a repair is necessary, please proceed as follows:

You can download a return form (23 KB) from the Internet on our homepage www.vega.com under: "*Downloads - Forms and certificates - Repair form*".

By doing this you help us carry out the repair quickly and without having to call back for needed information.

- Print and fill out one form per instrument
- Clean the instrument and pack it damage-proof
- Attach the completed form and, if need be, also a safety data sheet outside on the packaging
- Please ask the agency serving you for the address of your return shipment. You can find the respective agency on our website www.vega.com under: "*Company - VEGA world-wide*"

8 Dismounting

8.1 Dismounting steps

**Warning:**

Before dismounting, be aware of dangerous process conditions such as e.g. pressure in the vessel, high temperatures, corrosive or toxic products etc.

Take note of chapters "*Mounting*" and "*Connecting to power supply*" and carry out the listed steps in reverse order.

8.2 Disposal

The instrument consists of materials which can be recycled by specialised recycling companies. We use recyclable materials and have designed the electronics to be easily separable.

WEEE directive 2002/96/EG

This instrument is not subject to the WEEE directive 2002/96/EG and the respective national laws (in Germany, e.g. ElektroG). Pass the instrument directly on to a specialised recycling company and do not use the municipal collecting points. These may be used only for privately used products according to the WEEE directive.

Correct disposal avoids negative effects to persons and environment and ensures recycling of useful raw materials.

Materials: see chapter "*Technical data*"

If you cannot dispose of the instrument properly, please contact us about disposal methods or return.

9 Supplement

9.1 Technical data

General data

Material 316L corresponds to 1.4404 or 1.4435

Materials, wetted parts

- Process fitting - thread PP
- Process seal Klingersil C-4400
- insulation (fully insulated) PP

Materials, non-wetted parts

- Housing Plastic PBT (Polyester), Alu die-casting powder-coated
- Seal between housing and housing cover Silicone (Aluminium/plastic housing)
- Ground terminal 316L

Weights

- with plastic housing approx. 800 g (28 oz)
- with Aluminium housing approx. 1600 g (56 oz)
- Rod weight \varnothing 33 mm (1.3 in) approx. 560 g/m (6 oz/ft)

Sensor length (L) 150 ... 2000 mm (5.9 ... 78.7 ft)

Active tip (LA) 90 mm (3.5 ft)

Max. lateral load 5 Nm (3.7 lbf ft)

Max. torque (process fitting - thread) 30 Nm (22 lbf ft)

Frequency 430 kHz

Output variable

Output Relay output (DPDT), 2 floating spdts

Turn-on voltage

- Min. 10 mV
- Max. 253 V AC, 253 V DC

Switching current

- Min. 10 μ A
- Max. 3 A AC, 1 A DC

Breaking capacity	
– Min.	50 mW
– Max.	750 VA AC, 54 W DC
	If inductive loads or stronger currents are switched through, the gold plating on the relay contact surface will be permanently damaged. The contact is then no longer suitable for switching low-level signal circuits.
Potential separation	min. 500 V DC
Contact material (relay contacts)	AgNi or AgSnO and Au plated
Modes (adjustable)	A (overflow protection)/B (dry run protection)
Switching delay	
– when immersed	approx. 0.7 s
– when laid bare	approx. 0.7 s
– in case of failure	approx. 1 s

Ambient conditions

Ambient temperature on the housing	-40 ... +80 °C (-40 ... +176 °F)
Storage and transport temperature	-40 ... +80 °C (-40 ... +176 °F)

Process conditions

Process pressure	unpressurized
Process temperature VEGACAP 98 of PP	-30 ... +80 °C (-22 ... +176 °F)
Dielectric figure	≥1.5

Electromechanical data

Cable entry/plug (dependent on the version)	
– Single chamber housing	<ul style="list-style-type: none"> • 1x cable entry M20x1.5 (cable-ø 5 ... 9 mm), 1x blind stopper M20x1.5; attached 1x cable entry M20x1.5 or: <ul style="list-style-type: none"> • 1x cable entry ½ NPT, 1x blind stopper ½ NPT, 1x cable entry ½ NPT or: <ul style="list-style-type: none"> • 1x plug M12x1, 1x blind stopper M20x1.5
Screw terminals	for wire cross-section up to 1.5 mm ² (0.0023 in ²)

Adjustment elements

Mode switch

- A Min. detection or dry run protection
- B Max. detection or overflow protection

Potentiometer

Switching point adaptation

Voltage supply

Supply voltage

20 ... 253 V AC, 50/60 Hz, 20 ... 72 V DC (at U >60 V DC, the ambient temperature can be max. 50 °C/122 °F)

Power consumption

1 ... 9 VA (AC), approx. 1.5 W (DC)

Electrical protective measures

Protection

IP 66/IP 67

Overvoltage category

III

Protection class

I

Approvals

Overflow protection according to WHG

9.2 Dimensions

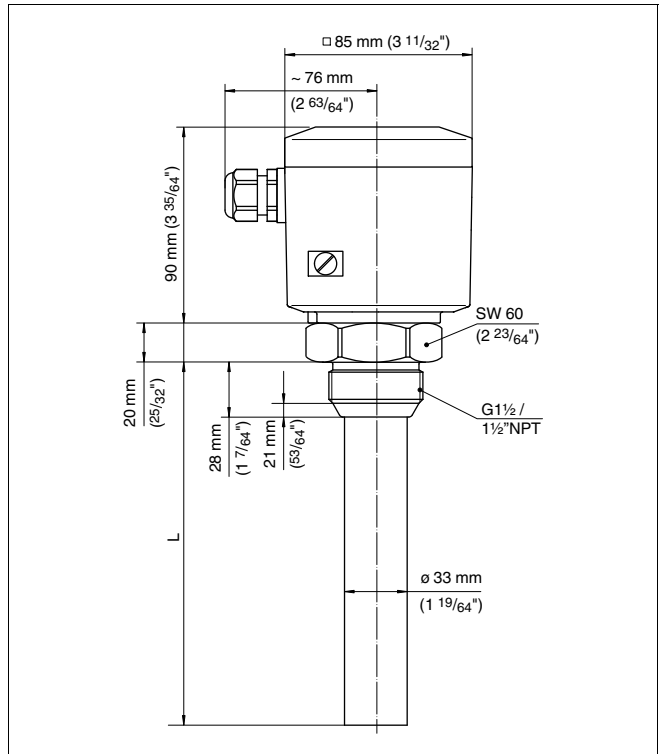

Fig. 24: VEGACAP 98, threaded version G1 1/2 A
 L = Sensor length, see chapter "Technical data"

9.3 Industrial property rights

VEGA product lines are global protected by industrial property rights.

Further information see <http://www.vega.com>.

Only in U.S.A.: Further information see patent label at the sensor housing.

VEGA Produktfamilien sind weltweit geschützt durch gewerbliche Schutzrechte.

Nähere Informationen unter <http://www.vega.com>.

Les lignes de produits VEGA sont globalement protégées par des droits de propriété intellectuelle.

Pour plus d'informations, on pourra se référer au site <http://www.vega.com>.

VEGA líneas de productos están protegidas por los derechos en el campo de la propiedad industrial.

Para mayor información revise la pagina web <http://www.vega.com>.

Линии продукции фирмы ВЕГА защищаются по всему миру правами на интеллектуальную собственность.

Дальнейшую информацию смотрите на сайте <http://www.vega.com>.

VEGA系列产品在全球享有知识产权保护。

进一步信息请参见网站<<http://www.vega.com>>。

9.4 Trademark

All brands used as well as trade and company names are property of their lawful proprietor/originator.



VEGA Grieshaber KG
Am Hohenstein 113
77761 Schiltach
Germany
Phone +49 7836 50-0
Fax +49 7836 50-201
E-mail: info@de.vega.com
www.vega.com



All statements concerning scope of delivery, application, practical use and operating conditions of the sensors and processing systems correspond to the information available at the time of printing.

© VEGA Grieshaber KG, Schiltach/Germany 2007