

VEGACAP 35

Relay (DPDT)

Capacitive cable electrode for level detection



Technical data

Sensor length	up to 20 m (65.62 ft)
Process fitting	Thread from G1½ A, 1½ NPT
Process pressure	-1 ... +16 bar (-100 ... +1600 kPa/-14.5 ... +232 psig)
Process temperature	-30 ... +80 °C (-22 ... +176 °F)
Ambient, storage and transport temperature	-40 ... +80 °C (-40 ... +176 °F)
Operating voltage	20 ... 253 V AC, 50/60 Hz; 20 ... 72 V DC
Power consumption	1 ... 8 VA (AC), approximately 1.5 W (DC)
Turn-on voltage	min. 10 mV, max. 253 V AC, 253 V DC
Switching current	min. 10 µA, max. 3 A AC, 1 A DC
Breaking capacity	min. 50 mW, max. 750 VA AC, 54 W DC
Switching delay	0.7 s (on/off)

Area of application

The VEGACAP 35 is an adjustment-free, capacitive level switch for bulk solids. Typical applications are overfill and dry run protection. The probe operates in products with a dielectric figure from 1.5.

Advantages

- Minimum time and cost expenditure thanks to simple setup without medium
- Exact switching point even with strong buildup or condensation
- Long lifetime and low maintenance requirement through robust mechanical construction

Function

Sensor and vessel form the two electrodes of a capacitor. A capacitance change caused by a level change is evaluated by the integrated electronics and converted into a switching signal. The capacitive measuring principle has no special requirements in respect to installation and mounting.

Materials

The wetted parts of the instrument are fully PE/PA 12 insulated. The gravity weight is made of stainless steel. You will find a complete overview of the available materials and seals in the "configurator" on our homepage under www.vega.com/configurator.

Housing versions

The housings are available in plastic or Aluminium. They are available with protection ratings up to IP 67.

Electronics versions

The instruments are available with a relay output (DPDT).

Approvals

The instruments are approved as overfill protection system according to the Water Resources Act (WRA).

You can find detailed information on the existing approvals in the "configurator" on our homepage under www.vega.com/configurator.

Operation

The mode and switching point of the level switch can be adjusted on the electronics module. A signal lamp shows the switching status of the instrument.

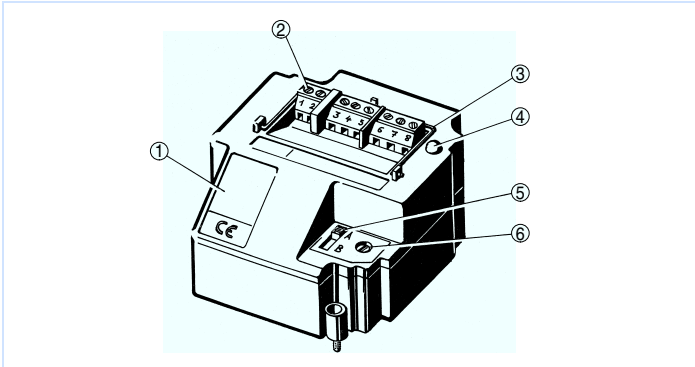

Oscillator with relay output

- 1 Type label
- 2 Connection terminals
- 3 Tensile proving ring
- 4 Control lamp
- 5 DIL switch for mode adjustment
- 6 Potentiometer for switching point adaptation

Information

You can find further information about the VEGA product line on our homepage www.vega.com. In the download section under www.vega.com/downloads you'll find free operating instructions, product information, brochures, approval documents, instrument drawings and much, much more.

Instrument selection

With the "finder" you can select the most suitable measuring principle for your application: www.vega.com/finder. You can find detailed information on the instrument versions in the "configurator" on our homepage under www.vega.com/configurator.

Contact

You can find the VEGA agency serving your area on our homepage www.vega.com.

Electrical connection

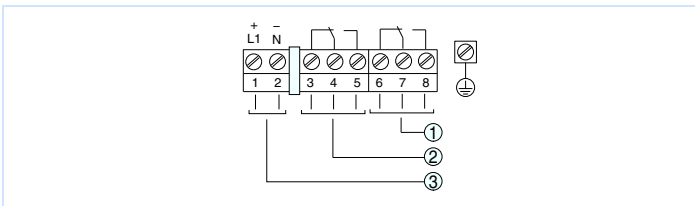

Wiring plan

- 1 Relay output
- 2 Relay output
- 3 Voltage supply

You can find details on the electrical connection in the instrument operating instructions on our homepage at www.vega.com/downloads.

Dimensions

