

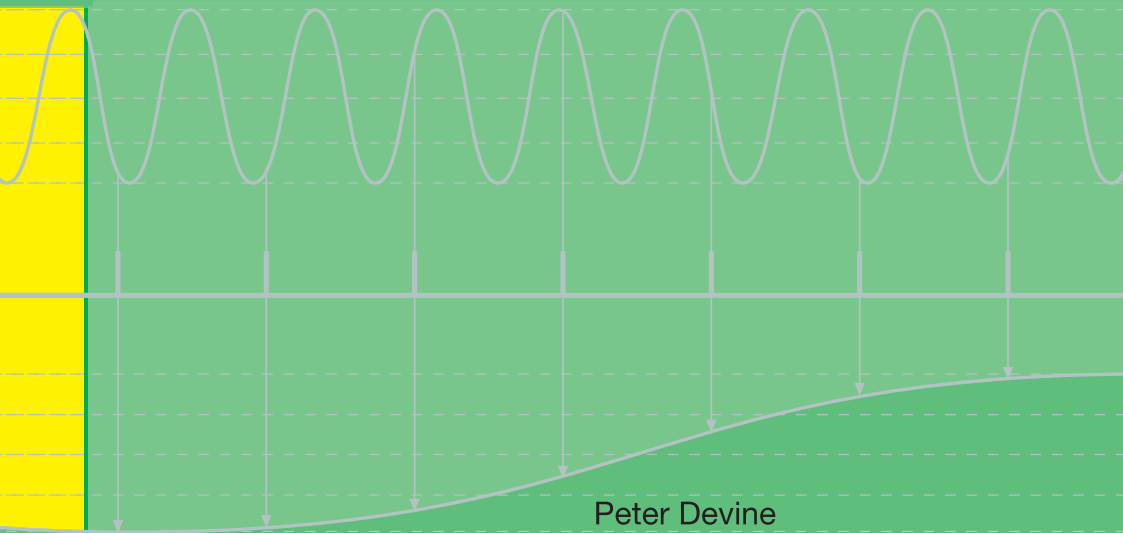

# **Radar level measurement**

*The user's guide*



# Contents

---

Foreword	ix
Acknowledgement	xi
Introduction	xiii

## Part I

<b>1. History of radar</b>	<b>1</b>
<b>2. Physics of radar</b>	<b>13</b>
3. Types of radar	33
1. CW-radar	33
2. FM - CW	36
3. Pulse radar	39

## Part II

<b>4. Radar level measurement</b>	<b>47</b>
1. FM - CW	48
2. PULSE radar	54
3. Choice of frequency	62
4. Accuracy	68
5. Power	74
<b>5. Radar antennas</b>	<b>77</b>
1. Horn antennas	81
2. Dielectric rod antennas	92
3. Measuring tube antennas	101
4. Parabolic dish antennas	106
5. Planar array antennas	108
Antenna energy patterns	110
<b>6. Installation</b>	<b>115</b>
<b>A. Mechanical installation</b>	<b>115</b>
<b>1. Horn antenna (liquids)</b>	<b>115</b>
<b>2. Rod antenna (liquids)</b>	<b>117</b>
<b>3. General consideration (liquids)</b>	<b>120</b>
<b>4. Stand pipes &amp; measuring tubes</b>	<b>127</b>
<b>5. Platic tank tops and windows</b>	<b>134</b>
<b>6. Horn antenna (solids)</b>	<b>139</b>
<b>B. Radar level installation cont.</b>	<b>141</b>
<b>1. safe area applications</b>	<b>141</b>
<b>2. Hazardous area applications</b>	<b>144</b>

# 6. Radar level installations



## A. Mechanical installation

Correct mechanical installation is very important for the efficient functioning of process radar level transmitters. Although the best echo processing

software can cope with some of the effects of poor installation, there is no substitute for correct installation at the design stage.

### I. Measurement of liquids - Horn antenna

#### Nozzle / socket

The most common installation for a radar sensor is made in a vessel nozzle or socket. The instrument flange is the reference plane of the measuring range.

The horn antenna should always protrude into the vessel by at least 10 mm. For example, a standard 6"

horn antenna is 205 mm long from the flange face.

If the vessel nozzle is significantly longer than 195 mm, a waveguide extension should be considered so that the end of the horn is the required distance within the vessel.

*Correct installation*

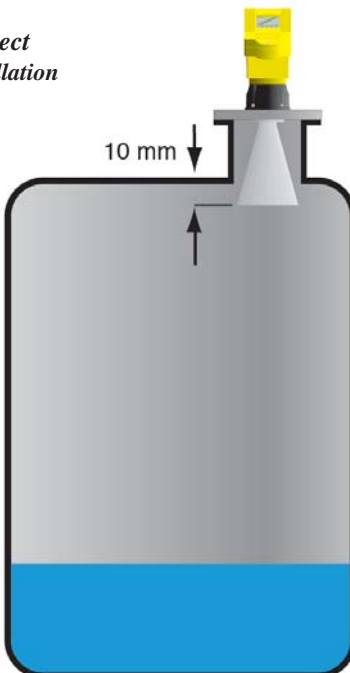

*Fig 6.1*

*Incorrect installation*

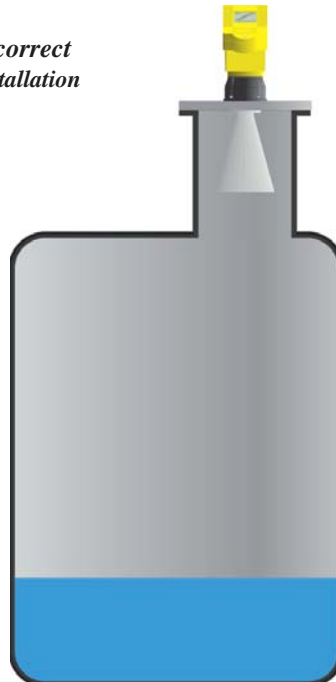

*Fig 6.2*

---

### Extended waveguide and curved waveguide horn

If a horn antenna radar has to be installed in a long tank nozzle, it can be fitted with a waveguide extension. This is a parallel stainless steel tube between the PTFE / ceramic waveguide in the flange and the horn of the antenna. Also, it is possible to bend the waveguide extension of a horn antenna through 90° for side mounting installations. The minimum bend radius for this type of antenna is 200 mm.

The orientation of the linear polarization of the radar is important with a 90° bend in the waveguide. The direction of the linear polarization should be horizontal if the bend turns vertically down.

Extended and bent waveguides are suitable for liquids with good reflective properties. They should not be used with low dielectric liquids or solids.

### Maximum level with a horn antenna radar

With a horn antenna installation it is normally possible to measure liquid levels right up to the end of the horn. Coating of a horn antenna does not present significant problems especially at a frequency of 5.8 GHz.

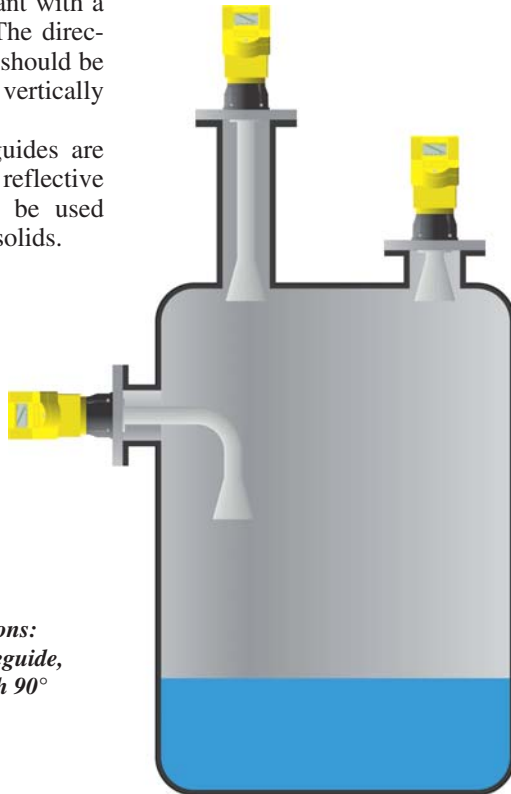

*Fig 6.3 Horn antenna installations: standard, extended waveguide, extended waveguide with 90° bend*

# 6. Radar level installations

## 2. Measurement of liquids - Rod antenna

### Nozzle / socket.

The PTFE rod antenna is well suited to chemically aggressive products such as acids and alkalis. It is used extensively within the pharmaceutical industry where mixtures of solvents, acids and alkalis are commonplace.

The PTFE rod antenna radar level sensors with Tri-Clamp fitting and crevice free construction are available for applications in the food processing industry and where hygienic vessel conditions are required.

The rod antenna is used for measuring liquids and slurries but not for dry solids applications. The sensor is most commonly mounted in a simple nozzle or socket.

Rod antenna radar transmitters are supplied with simple screwed connections such as 1 ½" BSP or NPT, flanged connections 2" (DN50) to 6" (DN150), or hygienic Tri-Clamp.

**It is essential that all of the tapered section of the rod antenna is inside the vessel and not in the nozzle.**

Rod antennas are available with inactive extended lengths so they can be installed in longer nozzles. Typically the extended versions are suitable for nozzles of up to 100 mm or up to 250 mm.

*Fig 6.4 Typical rod antenna installations: the active tapered section must be inside the vessel. Extended rod antennas should be used in longer nozzles*

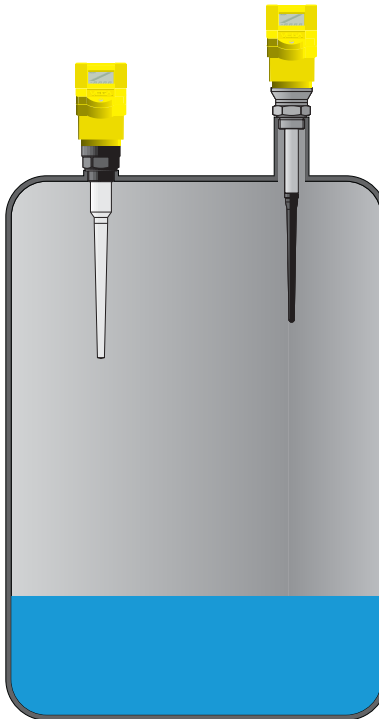

---

## Rod antenna incorrectly installed in a nozzle

If the tapered section of a rod antenna is installed inside a nozzle the microwaves that are emitted from the

antenna ‘ring’ inside the nozzle causing high levels of noise and therefore measurement problems especially in the near range.

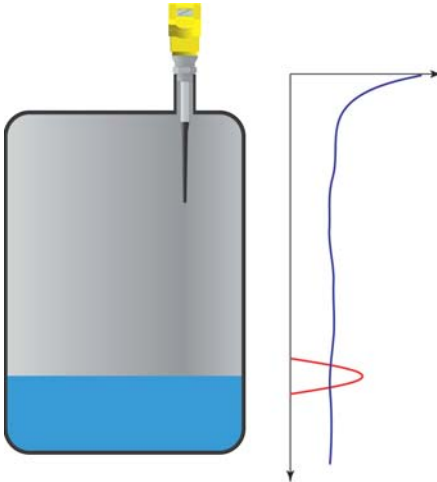

**Fig 6.5 Correct:**  
*Extended rod antenna for long nozzle. Normal noise curve with good echo*

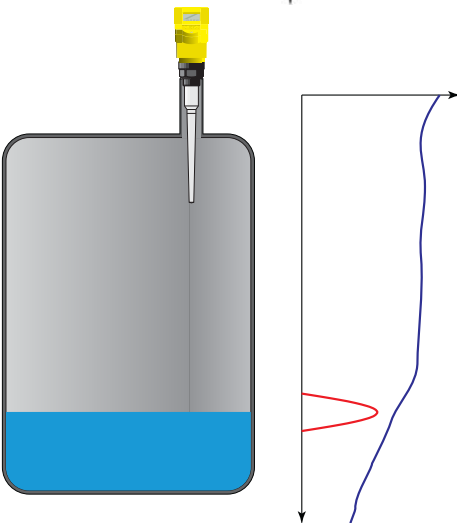

**Fig 6.6 Incorrect:**  
*Short rod antenna in long nozzle. High ‘ringing’ noise is produced which is above the echo signal*

## 6. Radar level installations

---

### **Rod antenna directly on the vessel opening**

Rod antenna radar sensors, either screwed or flanged, can be mounted directly into a hole in the top of a tank.

### **Maximum level with a rod antenna radar**

As explained previously, it is of primary importance that the tapered section of a rod antenna radar should be entirely within the vessel. The adverse effects of 'ringing' cannot be dealt with in software. Increased gain will only increase the ringing.

The length of the tapered section of a rod antenna means that we must consider the maximum level of liquid that could be present in the vessel.

**Ideally the liquid level should not touch a rod antenna.** However, this is sometimes unavoidable and the following considerations must be taken.

### **Mechanical loads**

It should be noted that PTFE-rod antennas can only withstand limited mechanical loads. When subjected to lateral force, it may bend and deform or even break. Does the application involve strong agitation? Will the force of the agitation cause damage to the rod?

### **Coating of a rod antenna**

As we have already explained, the microwaves from rod antenna radars are emitted from the tapered section of the rod. If the rod is submersed in viscous liquid and this product is allowed to coat the antenna, then the antenna efficiency will be compromised. The radar will not function if there is a serious amount of build up on a rod antenna. However, if light, low viscosity liquids such as solvents or low density water based products touch a rod antenna, they will tend to be self draining and self cleaning. As a rule of thumb, it is possible to measure clean, low viscosity liquids about half way up a rod antenna. However, the accuracy is compromised and no contact is always better.

### 3. General installation considerations: Horn and rod antennas on liquids applications

The following consideration should be taken into account when installing a

horn or rod antenna radar in the top of a vessel.

#### Mounting in dished topped vessels

A radar transmitter should not be mounted in the centre of the dished end of the tank or too close to the vessel wall. The ideal position is approximately a  $\frac{1}{2}$  vessel radius from the outer wall. Dished tank ends can act as parabolic reflectors. If the radar sensor is placed in the 'focus' of a parabolic tank end, the sensor receives amplified false echoes. Whereas if the radar sensor is mounted outside the 'focus' of the parabolic vessel top, amplified false echoes are avoided.

#### Parabolic effect

If a radar level transmitter is installed in the centre of a dished topped vessel, the unit will see large 'multiple echoes' beyond the real first echo. The effect of these multiple echoes can be clearly seen on an echo trace. The classic multiple echo form is shown in Fig 6.8. This same effect can occur in a horizontal cylindrical tank. Multiple echoes can be ignored by pulse radar software. However this problem is more difficult for FM - CW radar. See chapter 4.

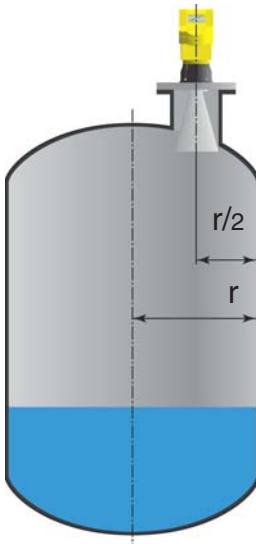

*Fig 6.7 The ideal position is  $\frac{1}{2}$  radius in vessels with a parabolic top*

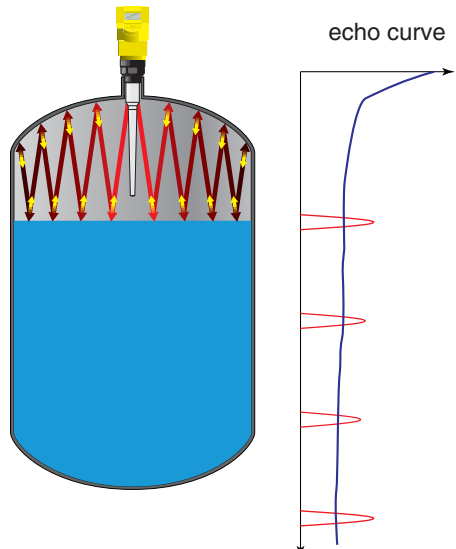

*Fig 6.8 The effect of mounting a radar in the middle of a parabolic dish vessel top*

## 6. Radar level installations

### False reflections

False echoes from flat obstructions or obstructions with a sharp edge, cause large false echoes. They produce high amplitude reflections of the radar signal. Rounded profile obstructions diffuse the reflection of the radar signals and produce low amplitude false echoes. Therefore they are easier to cope with than reflections from a flat surface.

If flat obstructions in the range of the radar signals cannot be avoided, it is recommended that a deflector plate is used to reflect the false echo signals away from the transmitter. These scattered false echo signals will be low in amplitude. Therefore, they can be filtered out by the sensor software.

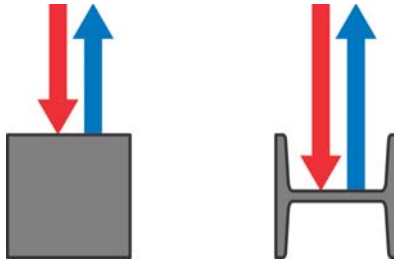

*Fig 6.9 Profiles with flat interfering surfaces or sharp edges cause large false echoes*

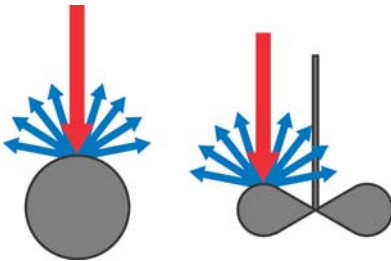

*Fig 6.10 Round profiles diffuse the radar signals producing smaller false echoes*

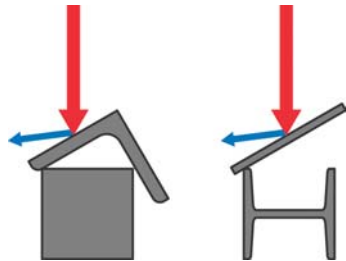

*Fig 6.11 A deflector causes signal scattering and reduces the amplitude of a false echo*

## Avoiding false echoes

The position of the radar sensor in the vessel must be selected such that no struts or in flowing material are in the direct path of the radar signal.

The following examples and instructions show common measurement problems and how they can be avoided.

### Shoulders

Vessel shapes which have flat shoulders pointing to the antenna can influence the measurement because of the

amplitude of the false echo. Deflectors above these flat shoulders deflect and diffuse the false echoes and ensure a reliable measurement.

Internal structures such as inlets for material mixing with a flat surface pointing to the radar sensor, should be covered by a screen. False echoes can then be ignored by the echo processing software.

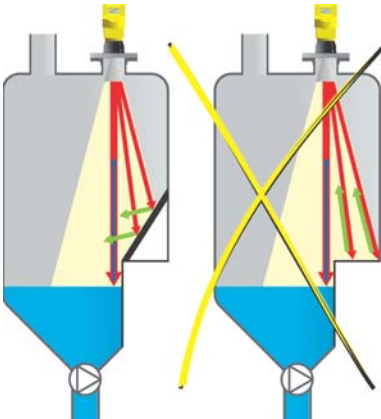

*Fig 6.12 Deflector plate on a vessel shoulder*

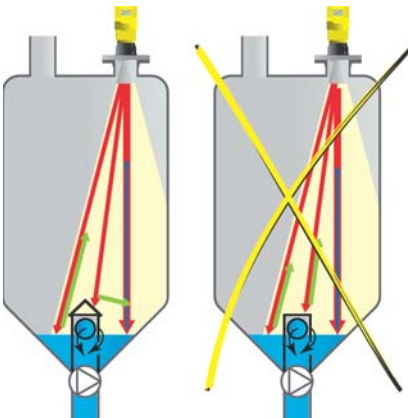

*Fig 6.13 Deflector plate on internal structure*

## 6. Radar level installations

### Vessel installations

Struts, such as ladders bracing and probes often cause false echoes. It is important to optimise the position of the radar level transmitter to avoid the worst effects of false echoes.

Internal bracing or welds can cause strong false echoes which can compete with the real product echo. Small

angled shields on bracing can avoid the worst false echo reflections. The false echoes are diffused and filtered out as 'echo noise' by the echo processing software. If internal welds are cleaned up during manufacture, their affect on the echo decision is minimised.

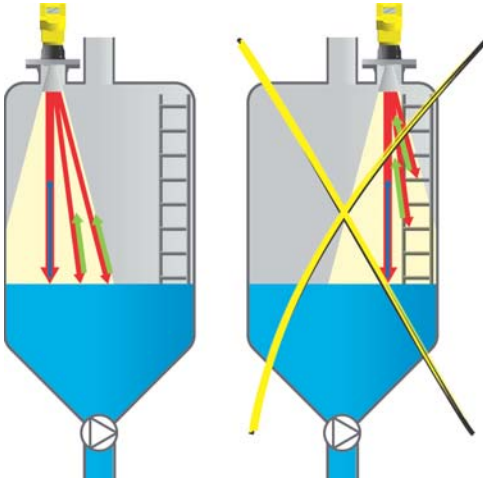

*Fig 6.14 The sensor must be positioned away from internal structures such as ladders*

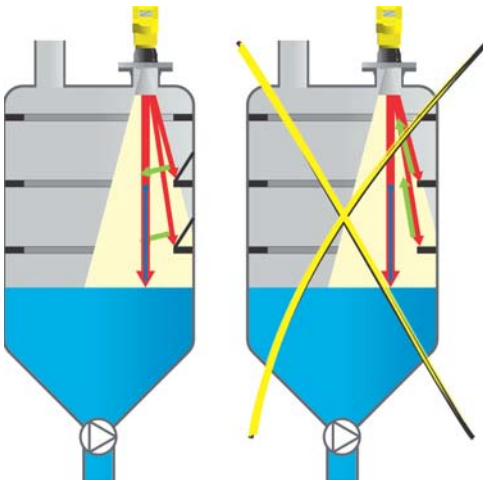

*Fig 6.15 Angled reflectors on internal structures such as bracing can reduce the effects of the false echoes*

---

## Build-up

If the radar sensor is mounted too close to the vessel wall, build-up on the vessel walls may cause false echoes.

Ideally, position the radar sensor away from the vessel wall. The optimum position for dished top vessels is at  $\frac{1}{2}$  radius.

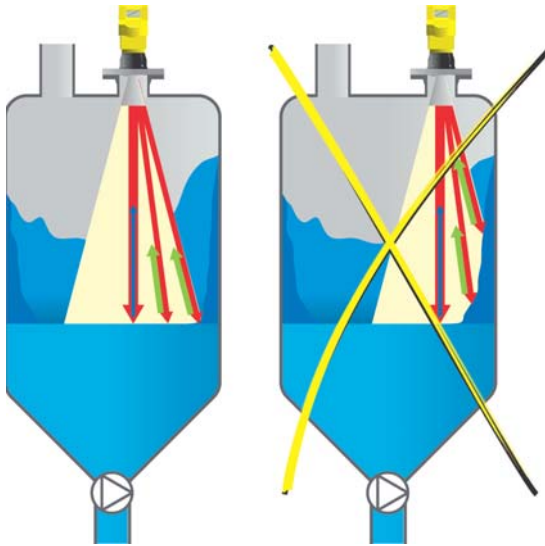

*Fig 6.16 Avoid the effects of build up on the side of a vessel*

## Polarization

As already discussed in Chapter 2, Physics of radar, the microwaves have linear polarization.

Although polarization is of greater importance in stilling tube and bypass tube applications, it can also be significant when measuring in the top of a vessel.

The amplitude of the false echoes from the internal structure of the tank can often be reduced by rotating the radar transmitter through  $45^\circ$  or  $90^\circ$ .

The direction of the polarization depends on the direction of the coupling from the microwave module. It should be marked on the transmitter.

## 6. Radar level installations

### Orientation of the radar transmitter on liquids (horn or rod antenna)

For liquids applications, the radar level transmitter must be directed vertically down on to the liquid surface. If it

is angled, it will receive a weak product echo signal and possibly larger false multiple echoes.

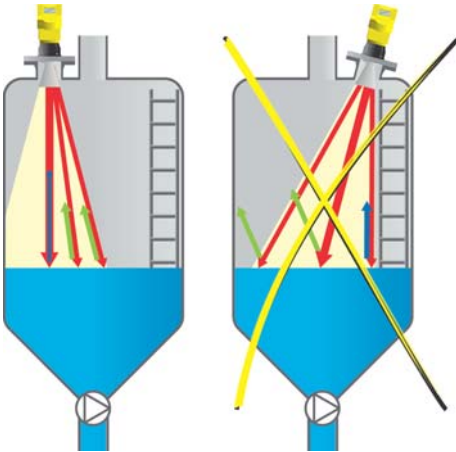
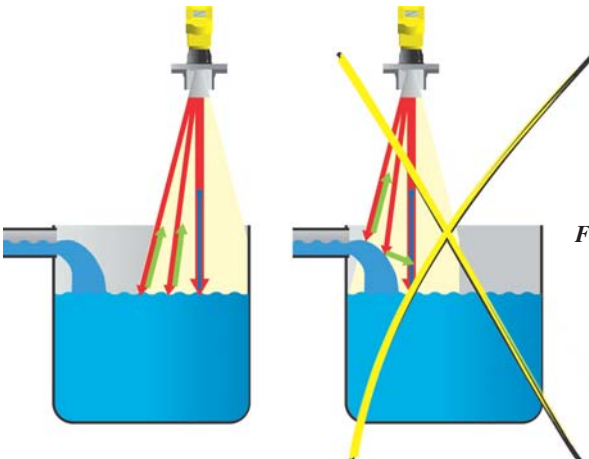

*Fig 6.17 The radar must be mounted vertically on liquids applications*

### In flowing liquid

Do not mount a radar sensor above or close to the liquid filling stream.

Ensure that you detect the product surface and not the in flowing material.



*Fig 6.18 Mount the transmitter away from in flowing liquid*

### Sensor too close to the vessel wall

If the radar sensor is mounted too close to the vessel wall it can cause strong interfering signals. Build-up, rivets, or weld joints superimpose their echoes on the real echo. Therefore, sufficient distance from the sensor to the vessel wall must be allowed.

Different radar level transmitters have different ‘beam angles’, see Chapter 5 on Radar antennas.

With good reflection conditions on liquids without disturbing echoes in the vessel, it is recommended that the distance of the sensor to the vessel wall complies with the inner emission cone. For liquids with false echo conditions it is recommended that the distance to the sensor complies with the outer emission cone. See Fig 6.19. Use manufacturers data.

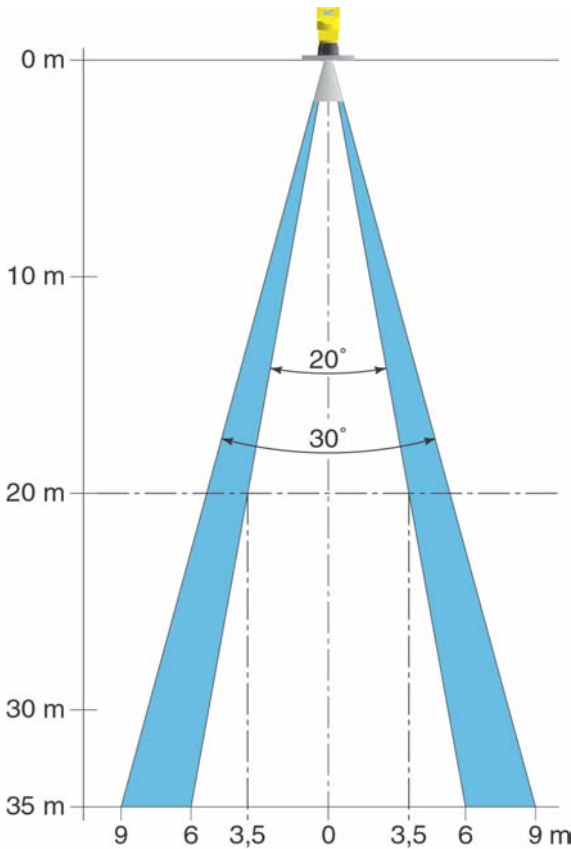

*Fig 6.19 Example 150 mm (6") horn antenna emission cone at 5.8 GHz*

## 6. Radar level installations

---

### 4. Stand pipes, stilling tubes & bypass tubes

Radar level transmitters are widely used in stand pipes, stilling tubes and bypass tubes. This type of installation may be essential where there is foam, heavy turbulence, mechanically complex vessels and sumps or very low dielectric liquids. Also, radar level transmitters have been used to replace existing sensors that utilise bypass tubes. This includes replacing displacers and float devices.

#### Foam generation

Dense conductive foam on the product can cause faulty measurement. Under these conditions it is probable that the radar will read the top of the foam. Often, radar can see the liquid surface through some lighter foams. However, the picture is not black and white and care must be taken in applications where foam is generated. The effects of foam can be avoided by measuring in a stilling tube or bypass tube. It is best to discuss the application with the manufacturer.

#### Very low dielectric constant liquids

Non-conductive and extremely low dielectric constant liquids such as LPG (liquefied petroleum gas) can be measured accurately and confidently using a measuring tube or bypass tube. As already explained in Chapter 5, 'Radar antennas', the measuring tube effectively concentrates the microwaves giving a large echo from the product surface. Dielectric constants as low as  $\epsilon_r = 1.5$  can be measured.

#### Highly agitated product surface

Heavy turbulence in the vessel caused by strong agitators or violent chemical reactions influence radar level measurement. A stilling tube or bypass tube of sufficient size allows reliable measurement even with strong turbulence in the vessel. This is provided that the product does not build-up inside the pipe. Products which can cause slight build-up can be measured by using a measuring tube of 100 mm (4") nominal bore or more. In a measuring pipe of this size, slight build-up is not a problem.

#### General instructions for radar measurement in a tube

The stand pipes or stilling tube must be open at the bottom and must extend over the full measuring range (i.e. down to 0% level). Ventilation and surge holes must be on one axis with the radar's linear polarization directed towards the holes or slots. The direction of the polarization may differ between manufacturers. On VEGA radars, the polarization is in the direction of the type plate or the casting nose.

As an alternative to the stand pipe or stilling tube in the vessel, a radar can be installed outside the vessel in a bypass pipe. The polarization must be directed towards the process connections which should be on the same axis as shown. (Fig 6.21).

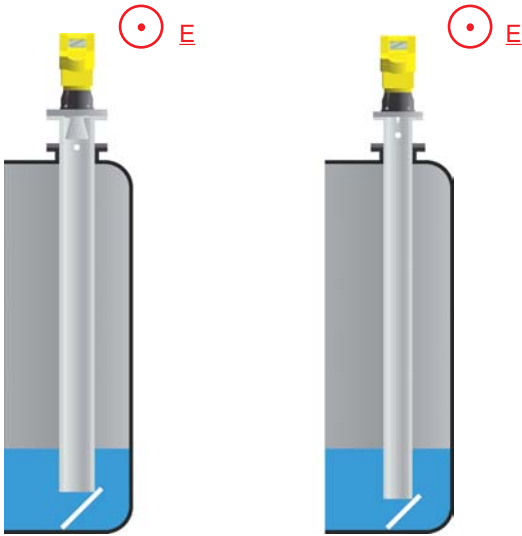

*Fig 6.20 Stand pipe / stilling tube showing position of vent relative to polarization direction and overall length*



*Fig 6.21 Bypass tube showing direction of polarization*



*Fig 6.22 Installation on bypass tube: Radar level transmitters often replace displacers or float devices*

## 6. Radar level installations

### Polarization

In summary, the sensor polarization must be directed towards the pipe connection opening in a bypass tube or the breather holes or slots in a stilling tube or stand pipe. The holes or slots must be on the same axis.

Directing the polarization of the radar signals enables considerably more stable measurements to be made in pipes because false echoes are reduced in amplitude.

### Microwave velocity change

As explained in Chapter 2 and Chapter 5, with measurement in a stand pipe or bypass tube the maximum measuring range is reduced between 5 and 20 %. This is because the running time of the microwaves in a tube is slower and therefore the maximum range is reduced. For example in a 50 mm (2") tube a maximum range of 20 metres is reduced to 16 metres and in a 100 mm (4") tube it is reduced to 19 metres.

### Measuring tube radar measurement with inhomogeneous products

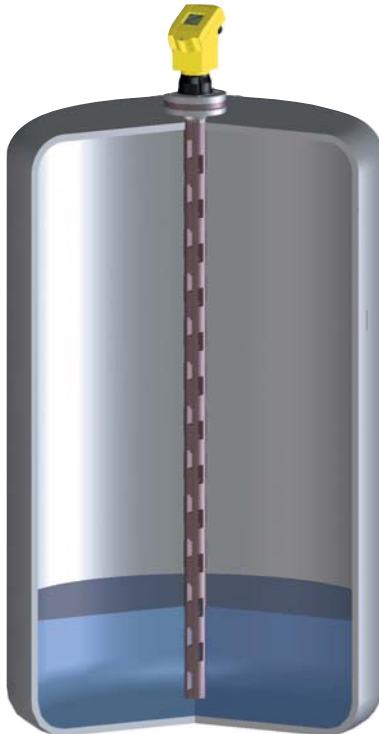
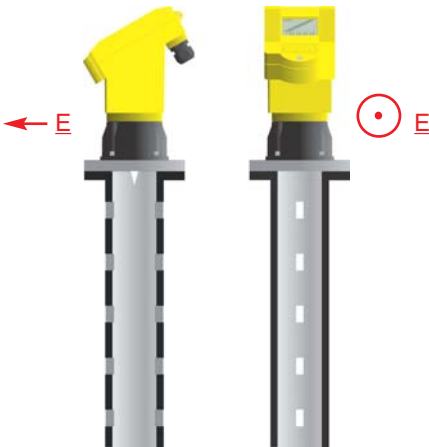

*Fig 6.23 Slots must be used to ensure that inhomogeneous liquids mix correctly. The polarization must be aimed towards the mixing slots or holes*

### Adhesive products

When measuring adhesive products, the inner diameter of the stand pipe must have a larger nominal diameter, for example 100 mm (4"), so that build-up does not cause measuring errors. In order to measure inhomogeneous liquids or liquids that separate into layers, the measuring tube must have long holes or slots in it. These openings ensure that the liquid is mixed and balanced at the correct level. The more inhomogeneous the measured product, the closer the openings should be.

Again, for reasons of radar signal polarization, the holes and slots must be positioned in two rows displaced by 180°. The radar sensor should be mounted such that the polarization is directed towards the rows of holes.



**Fig 6.24** Radar polarization must be aimed towards the mixing slots or holes

### Surge pipe with ball valve

A full bore ball valve can be used with a radar level transmitter on a stand pipe. The ball valve makes it possible for maintenance work to be carried out without opening the vessel. This is particularly useful with liquefied gas and toxic products. The full bore ball valve must have the same diameter as the pipe and be flush when it is in the open position.

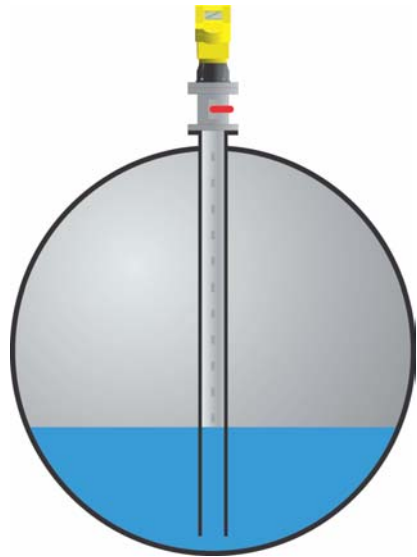

**Fig 6.25** A full bore ball valve on a stilling tube can be used to isolate a radar from the process without the need for a shut down

## 6. Radar level installations

---

### Construction of radar stand pipes

#### Diagram 1 (P132)

Radar sensors for measurement on stand pipes or bypass tubes are used in flange sizes DN 50 (2"), DN80 (3"), DN100 (4") and DN150 (6").

This diagram (Diagram 1) shows the construction of a measuring tube (stand pipe or bypass tube) with a DN 50 (2") flange.

The measuring tube must be smooth inside (average roughness  $R_z < 30$ ). Ideally a continuous stainless steel (or Hastelloy) pipe should be used without any joints in the measuring area.

If pipe extensions are required, these should be manufactured to length with weld neck flanges or with connecting sleeves. The transition between pieces of pipe should be smooth and no shoulders should be caused by welding.

The pipe and the flange should be fastened with the internal bore aligned before welding.

The pipe must be smooth inside. Do not weld through the pipe wall.

Pipe roughness and joints must be removed carefully or large false echoes may cause a measurement problem and build-up will adhere to the uneven surface. All burrs must be removed from holes and slots.

#### Diagram 2 (P133)

This diagram (Diagram 2) shows the construction of a measuring tube for a radar level sensor with a DN 100 (4") flange.

Radar sensors with flanges of DN 80 (3"), DN 100 (4") and DN 150 (6") are usually equipped with a horn antenna. Special offset rod antenna transmitters are available for DN50 (2") and DN80 (3") flange connections.

Instead of the weld neck flange of the tube, a smooth welding flange can be used for the transmitter connection flange which is above the horn antenna.

The measuring pipe should be secured to the vessel bottom if there is agitation. Additional fastenings will be required for longer measuring tubes.

A deflector plate at the end of the measuring tube reflects the radar signals away from the bottom of the vessel. This is designed to avoid large echoes from the metal bottom of the vessel caused by the microwave penetrating low dielectric products, such as solvents, when the level is low.

In some cases, the vessel bottom echo will interfere with the liquid level echo. The deflector plate prevents this problem from occurring.

# Diagram I

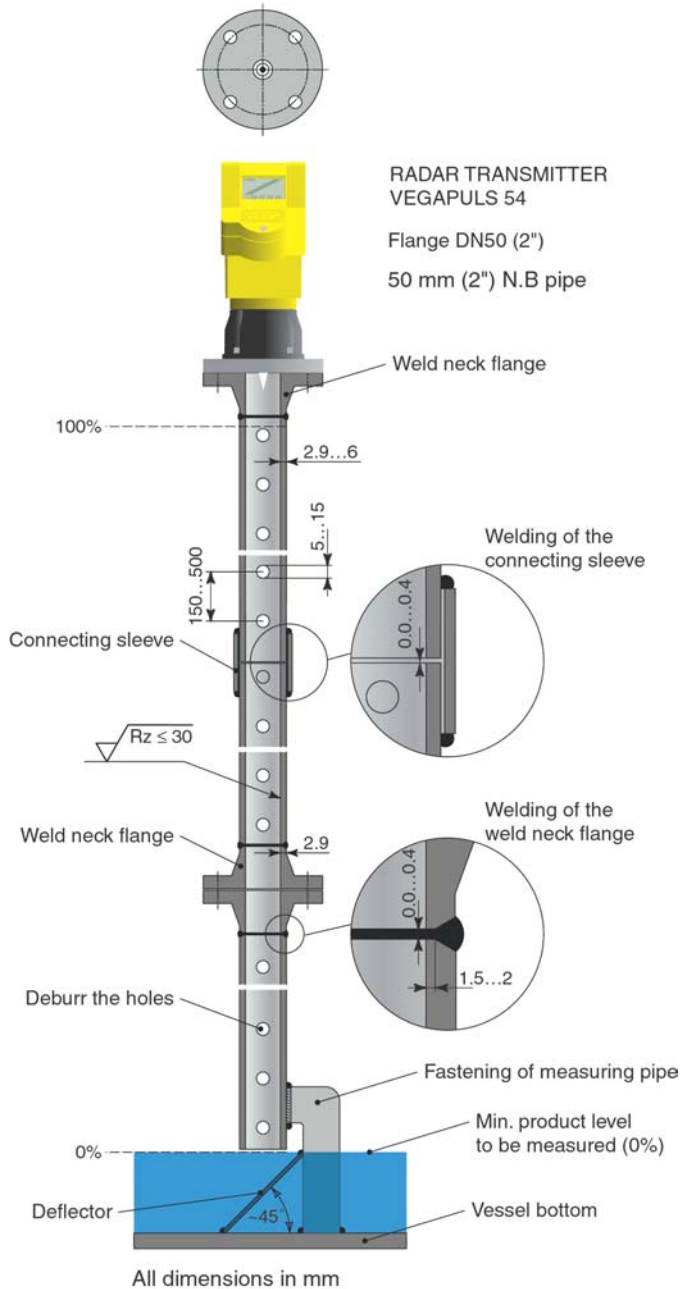

Fig. 6.26



---

## 5. Measurement through plastic tank tops & low dielectric windows

The microwave signals from radar level transmitters are capable of penetrating low dielectric materials such as PTFE, polypropylene, glass and GRP (glass reinforced plastic). This ability is very important for some applications. For example, where high purity is required for the semi-conductor industry or where substances are very aggressive in the chemical industry, it is beneficial that the system remains closed for reasons of quality and safety.

A completely non-contact level measurement is possible for products with good reflection properties where the radar measurement can be carried out through the top of plastic vessels.

Products with good electrical conductivity or with a dielectric constant of more than 10 can be measured in this way.

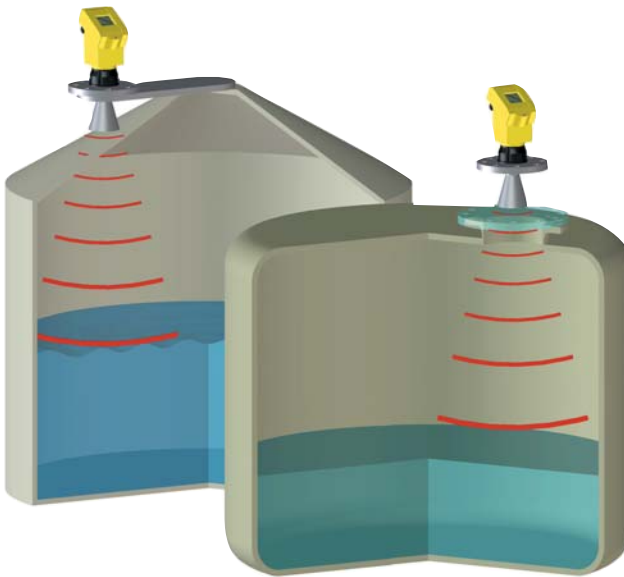

*Fig 6.28 Measurement of reflective liquids can be carried out through low dielectric windows or plastic tank tops*

## 6. Radar level installations

### Reflection of microwaves - plastic tank top

As with light, microwaves follow the laws of reflection. As well as penetrating the plastic tank top and reflecting off the conductive or high dielectric liquid, there is also a small reflection from the plastic tank. If the tank ceiling is flat, the false echo from the plastic will reflect directly back to the antenna. See Fig 6.29.



*Fig 6.29 Flat plastic tank top gives a reflection directly back to the antenna*

The performance of the radar is improved if the plastic tank top is sloped at an angle of  $35^\circ$  to  $45^\circ$ , and the antenna is about 400 mm (16") from the plastic ceiling of the tank.

The angle ensures that the reflection from the plastic tank is carried away from the antenna and if does not interfere with the real echo off the product. See Fig 6.30.



*Fig 6.30 Angled plastic tank top improves the measurement of the liquid inside*

### Measurement through low dielectric window

Pulse radar can also be used to look through low dielectric windows in metallic vessels. As with plastic tanks, the window has to be large enough to cope with the beam angle of the sensor, the window should be angled and the

antenna should not be too close to the window.

**Note:** Laws on the use of radar level transmitters outside vessels varies between different countries.

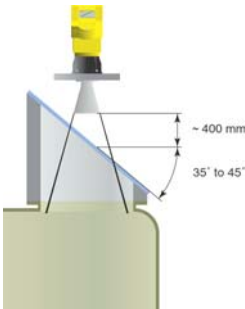

*Fig 6.31 Optimum installation position for a 5.8 GHz pulse radar looking through a low dielectric window*

---

### Measurement through a low dielectric window

In some countries it is not permitted to allow FM - CW radar level sensors to transmit outside an enclosed metal vessel. Therefore, if the benefits of a low dielectric window are to be realised, the antenna must be installed in a metallic spool piece above a plastic or glass window.

A refinement to the installation of radar level transmitters looking through

low dielectric windows is the use of a cone shaped PTFE seal. This can act as a dielectric lens focusing the microwaves. Also, it is less prone to problems of condensation because the liquid will tend to drain off the shaped seal. This type of installation may cause ringing noise.

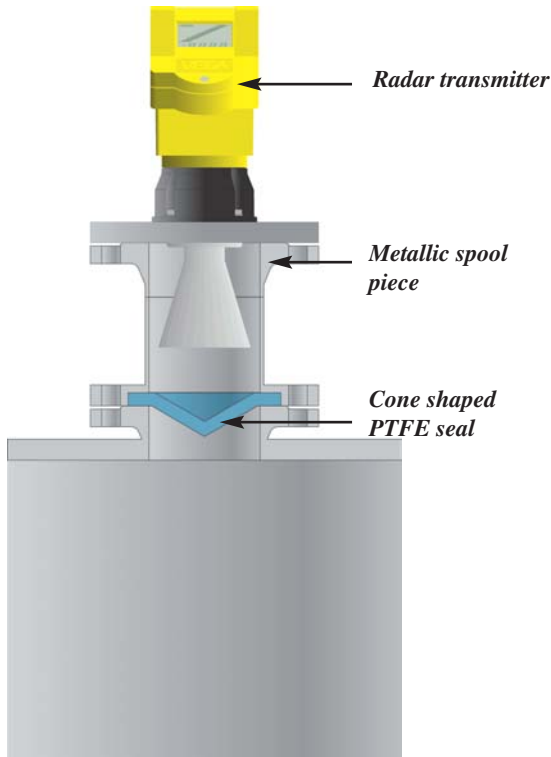

**Fig 6.32**

## 6. Radar level installations

### Optimizing the dielectric window

It is important to choose the correct thickness of dielectric material when measuring through a window.

The possible interference from the window is composed of two different echoes. The first echo is from the outside face of the window material as the microwaves penetrate the window. There is a  $180^\circ$  phase shift of the microwaves when it is reflected from the first surface.

The second echo is an internal reflection as the microwaves leave the window material. This is reflected without a phase shift. By choosing a window material thickness that is a half wavelength of the window material, the two out of phase reflections effectively cancel each other out through destructive interference. See chapter 2.

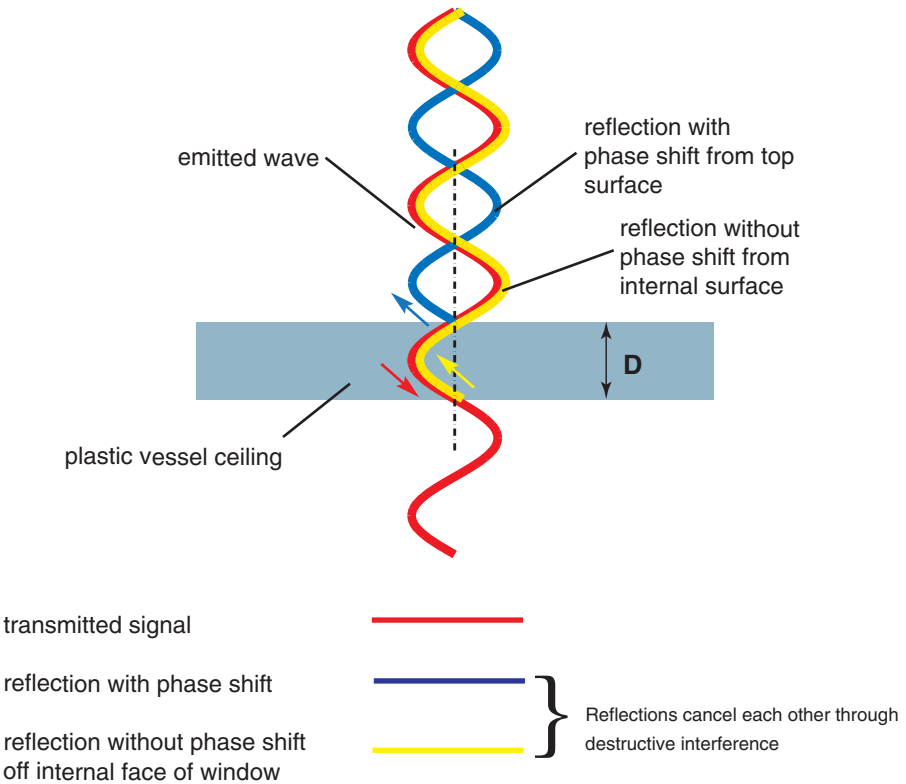

*Fig 6.33 The optimum thickness of the window material must be a half wavelength of the window material*

The following table shows the optimum thickness for the most important plastics and glasses that are suitable

The optimum thickness is shown for 5.8 GHz radar and 26 GHz radar.

<b>Low dielectric windows for pulse radar transmitters : Frequency 5.8 GHz</b>			
<b>Penetrated substance</b>	$\epsilon_r$	optimum thickness	D in mm
PE Polyethylene	2.3	17	(34; 51 ...)
PTFE Polytetrafluorethylene	2.1	18	(36; 54 ...)
PVDF Polyvinylidenfluoride	~7	8	(16; 24; 32 ...)
PP Polypropylene	2.3	17	(34; 51 ...)
Glass Borosilicate (Maxas, Duran)	5.5	11	(22; 33; 34 ...)
Glass Rasotherm	4.6	12	(24; 36; 48 ...)
Glass Labortherm	8.1	9	(18; 27; 36 ...)
Quartz glass	~4	13	(26; 39; 52 ...)
POM Polyoxymethylene	3.7	13.5	(27; 40.5; 54 ...)
Polyester	4.6	12	(24; 36; 48 ...)
Plexiglass Polyacrylate	3.1	14.5	(29; 43.5; 58 ...)
PC Polycarbonate	~2.8	16	(32; 48 ...)

window materials for radar sensors.

<b>Low dielectric windows for pulse radar transmitters : Frequency 26 GHz</b>			
<b>Penetrated substance</b>	$\epsilon_r$	optimum thickness	D in mm
PE Polyethylene	2.3	3.8	(7.6; 11.4...)
PTFE Polytetrafluorethylene	2.1	4	(8.0; 12.0...)
PVDF Polyvinylidenfluoride	~7	1.8	(3.6; 5.4...)
PP Polypropylene	2.3	3.8	(7.6; 11.4...)
Glass Borosilicate (Maxas, Duran)	5.5	2.5	(5; 7.5...)
Glass Rasotherm	4.6	2.7	(5.4; 8.1...)
Glass Labortherm	8.1	2	(4.0; 6.0; 8.0...)
Quartz glass	~4	2.9	(5.8; 8.7...)
POM Polyoxymethylene	3.7	3	(6.0; 9.0...)
Polyester	4.6	2.7	(5.4; 8.1...)
Plexiglass Polyacrylate	3.1	3.2	(6.4; 9.6...)
PC Polycarbonate	~2.8	3.6	(7.2; 10.8...)

**Note:** The optimum thickness can also be provided by the addition of several layers of identical material. The layers must fit flush without any gaps. Multiples of the half wavelength thickness can be considered too.

## 6. Radar level installations

### 6. Measurement of solids - Horn antenna

Horn antennas are used on solids applications. This includes all pneumatically conveyed products such as powders, granular products and pellets. The rod antenna is not used for these products but is used on liquids and slurries.

The product profiles of solids within a hopper or silo are rarely flat. A powder or granular product fills and empties with different profiles. The angle of repose of the product depends upon the type of product, the method of filling and emptying, and the shape and dimensions of the silo.

Radar level transmitters, like ultrasonic transducers, should be mounted in an off centre position with the anten-

na tilted at an angle towards the draw point at the bottom of the silo cone.

The end of the horn should be protruding by at least 10 mm into the vessel.

The transmitter is angled so that the radar beam bisects the product to provide the optimum echo strength and an average contents value.

The radar transmitter should be installed away from the fill line and away from any internal structure in the silo that may produce large false echoes.

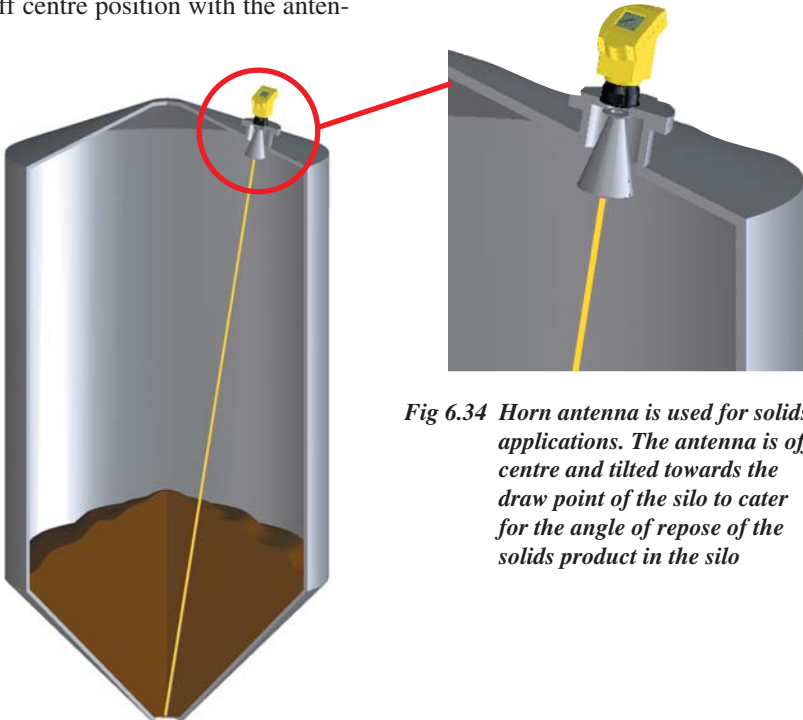

*Fig 6.34 Horn antenna is used for solids applications. The antenna is off centre and tilted towards the draw point of the silo to cater for the angle of repose of the solids product in the silo*

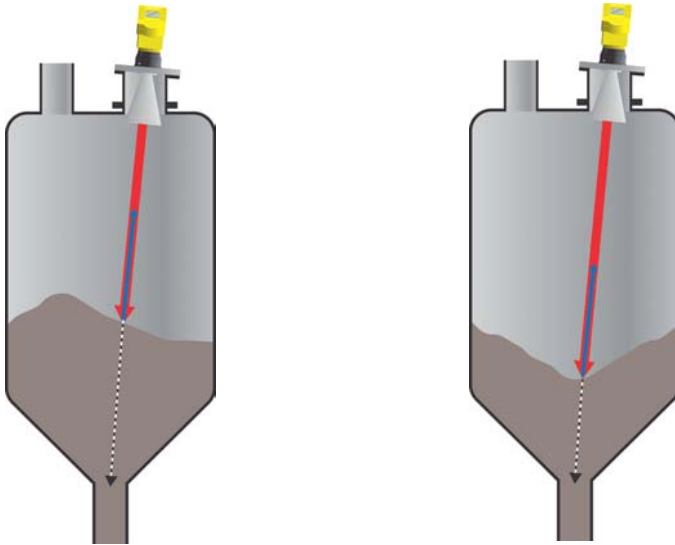
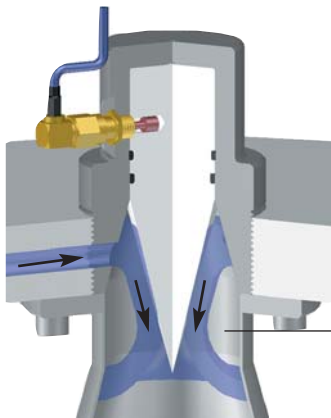

*Fig 6.35 & 6.36 Solids installation showing angle of repose on typical filling and emptying cycle*

### High temperature and contaminating solids applications

Air or nitrogen purging of the horn antenna can be used on high temperature solids applications or on applications where the product being measured coats and contaminates the anten-

na with thick layers of conductive dust. The flange is drilled laterally from two opposite directions and tapped to receive the air / nitrogen gas service.



*Fig 6.37 Air / Nitrogen cooling or contamination purging*

## 6. Radar level installations

### B. Electrical installation

The range of different radar level transmitters has expanded in recent years. There are a number of different wiring configurations available for safe area and hazardous area applications. These include 4 to 20 mA transmitters and fieldbus transmitters. The cost of cabling must be considered when choosing a radar sensor.

The advent of the two wire, intrinsically safe pulse radar has positioned radar as a ready replacement for the more traditional level transmitters such as differential pressure and displacers. However, practical FM - CW transmitters still require the additional power of a 4 wire device. In this section we look at the range of possible wiring configurations for all types of radar.

### I. Safe Area applications

- a. 2 wire, 4 to 20 mA loop powered radar

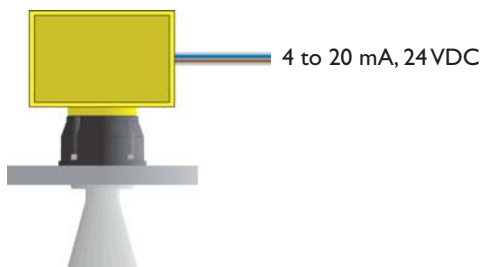

*Fig 6.38*

- b. 4 wire, 4 to 20 mA radar

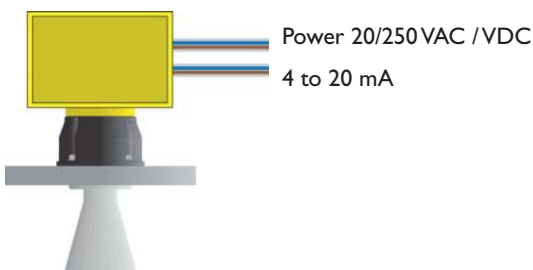

*Fig 6.39*

- c. HART protocol. Most two wire and 4 wire , 4 to 20 mA radar level transmitters are available with the HART protocol superimposed on the current loop. This allows the following:
- Remote set up with HART hand held programmer
  - Set up via HART protocol with remote I/O into DCS
  - Possible multi-drop of 16 units using HART protocol

- d. Fieldbus (VBUS), 15 sensors on two wires, multi-drop, safe area. Vegalog 571, type EV input cards (15 sensors) maximum of 255 measurement loops

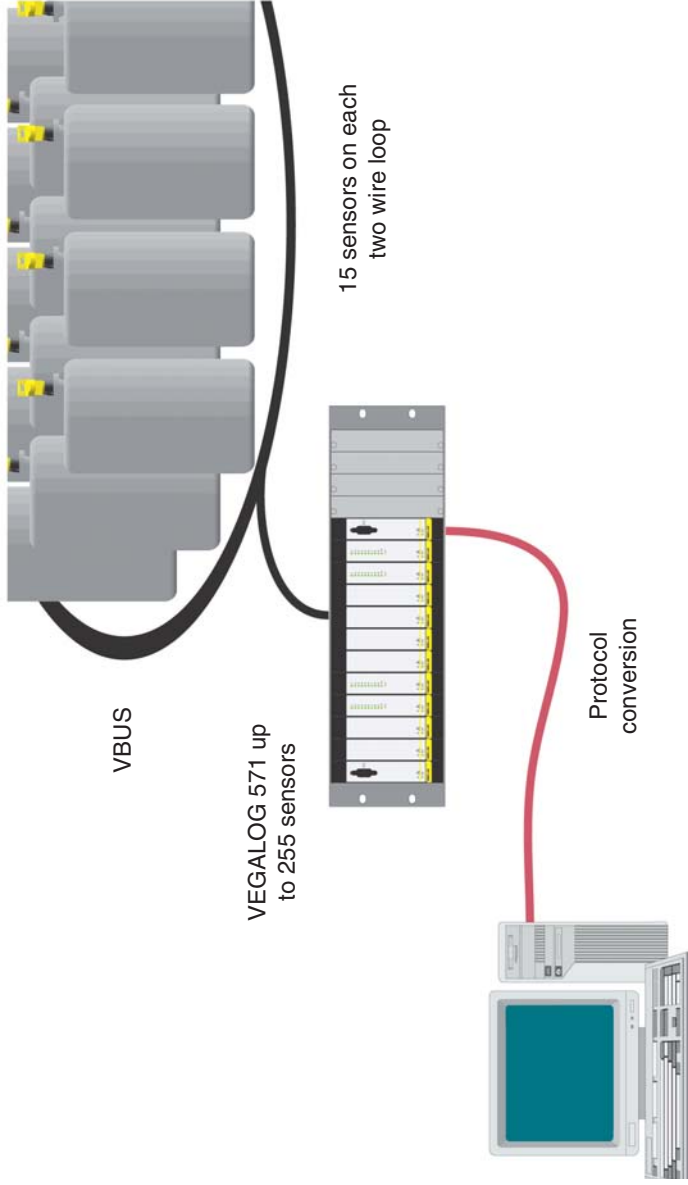

Fig 6.40

e. Fieldbus (PROFIBUS PA), 32 sensors on two wires via segment coupler, safe area

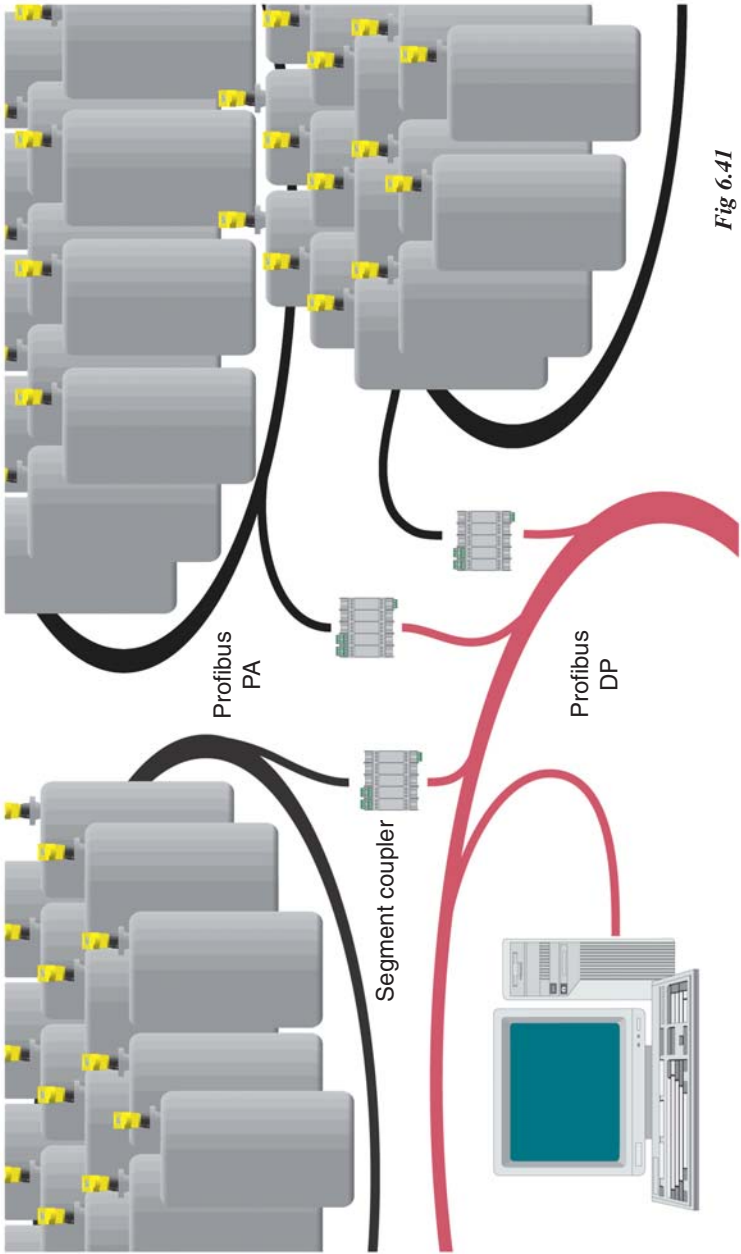
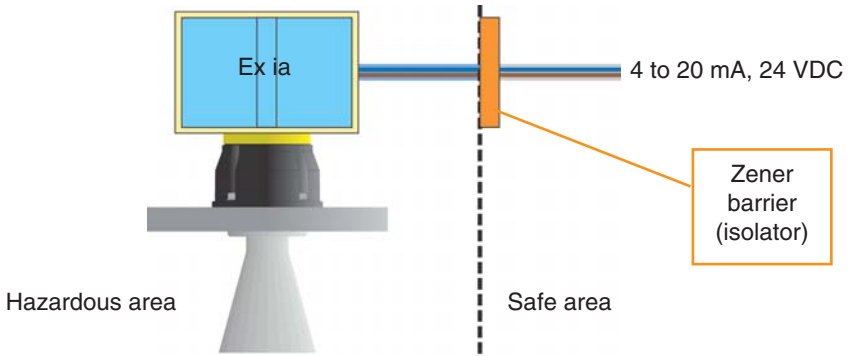

Fig 6.41

## 2. Hazardous area applications

- a. 2 wire, 4 to 20 mA, intrinsically safe, loop powered Ex 'ia' with HART protocol



*Fig 6.42*

- b. 2 wire, 4 to 20 mA, E Ex d ia, power 12 to 36 VDC increased safety wiring loop powered. Zener barrier between Ex d housing and I.S. compartment for adjustment and indicator - NO safe area isolator required

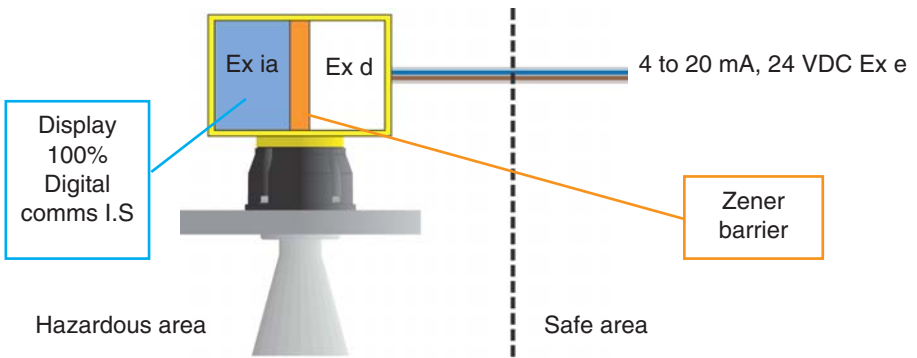

*Fig 6.43*

## 6. Radar level installations

- c. 4 wire, EEx d ia, Power 24 VDC (black cable) with isolated 4 to 20 mA two wire from housing

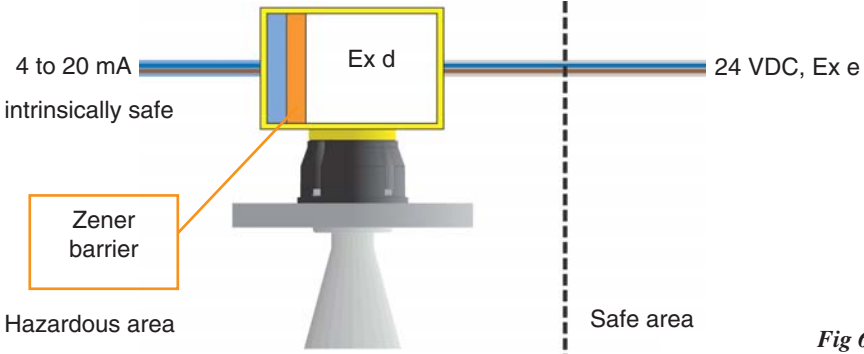

- d. 4 wire, 4 to 20 mA, Ex e wiring, Exd housing

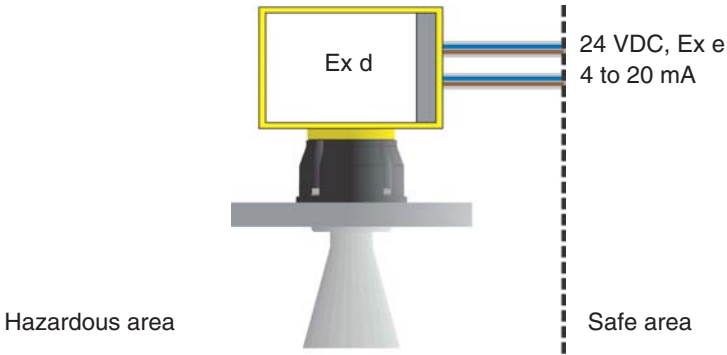

- e. 4 wire intrinsically safe with signal conditioning and isolator

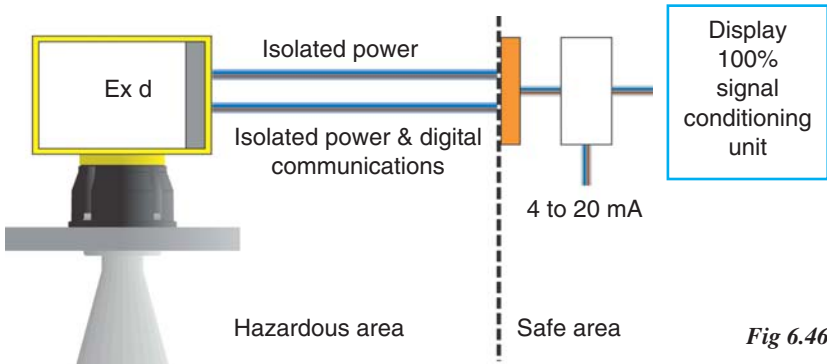

**f.** Fieldbus (VBUS), 15 sensors on two wires Ex e, multi-drop, hazardous area with increased safety wiring and separate increased safety power supply

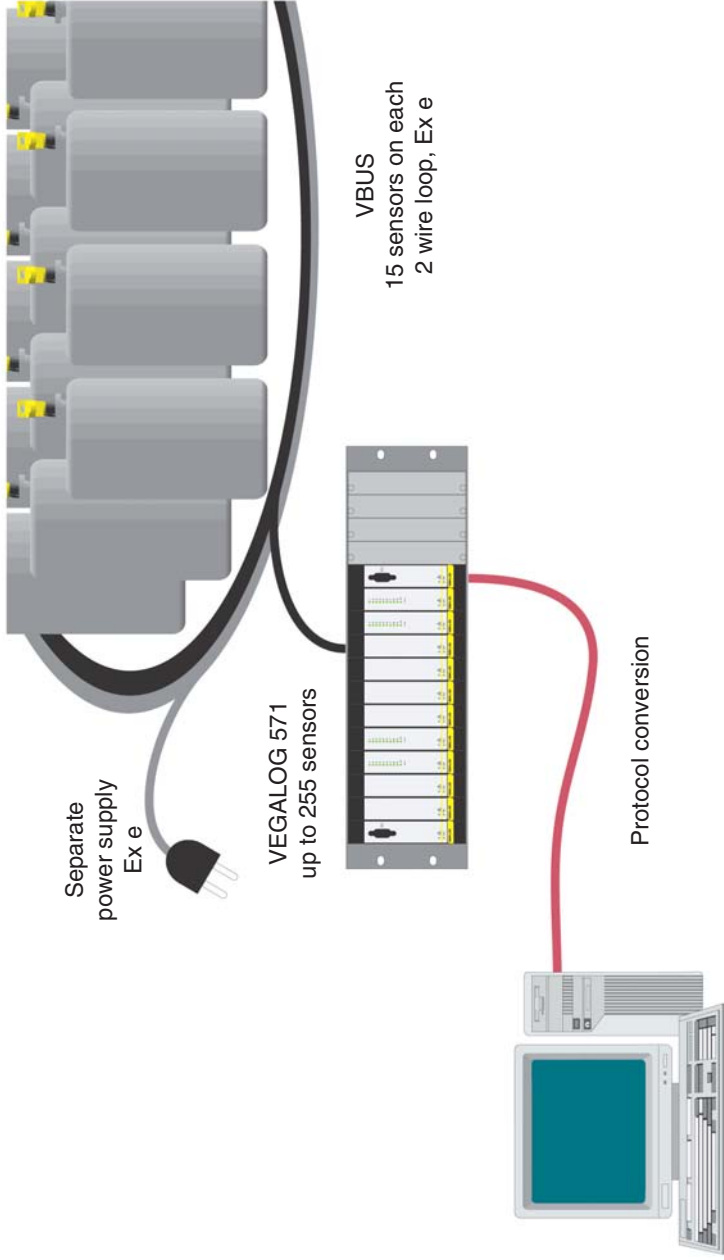

**Fig 6.47**

## 6. Radar level installations

- g. Fieldbus (VBUS), 15 sensors Ex e, 5 sensors on 3 two wire loops, multi-drop, hazardous area with increased safety wiring and increased safety power supply on each loop

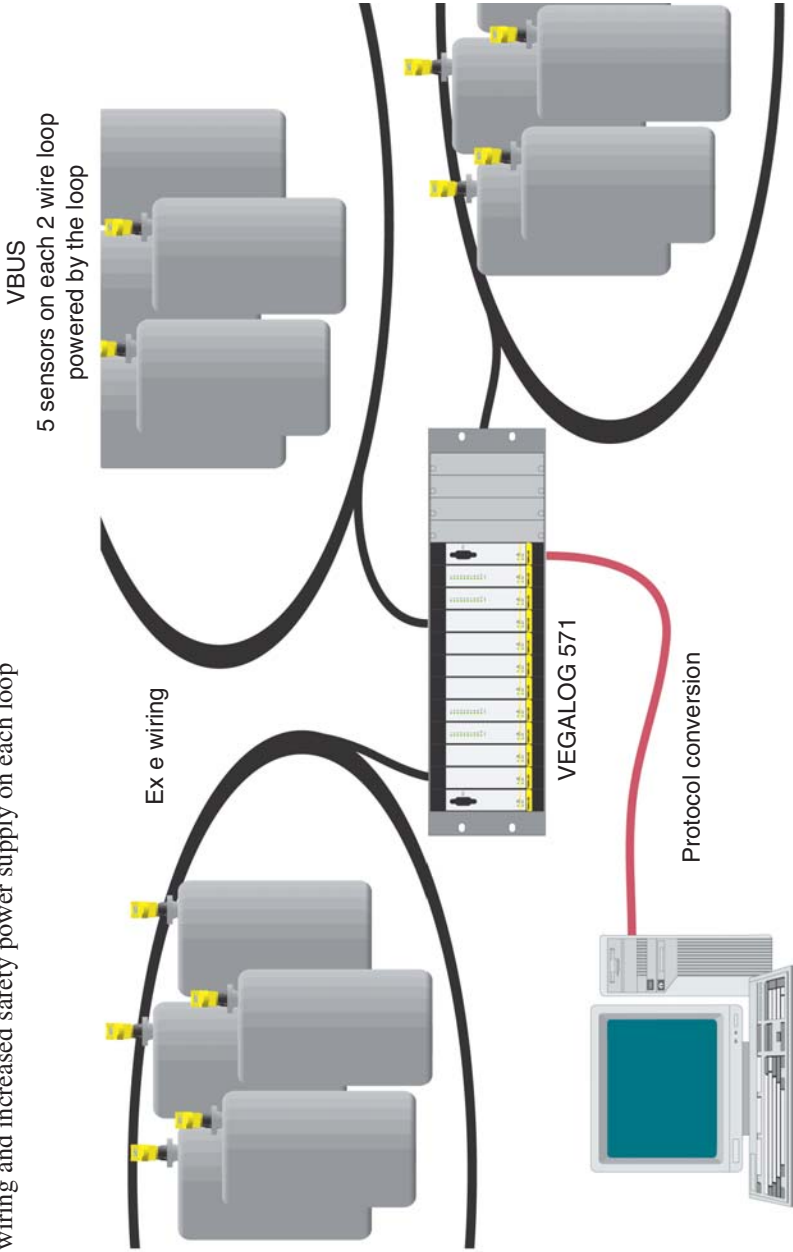
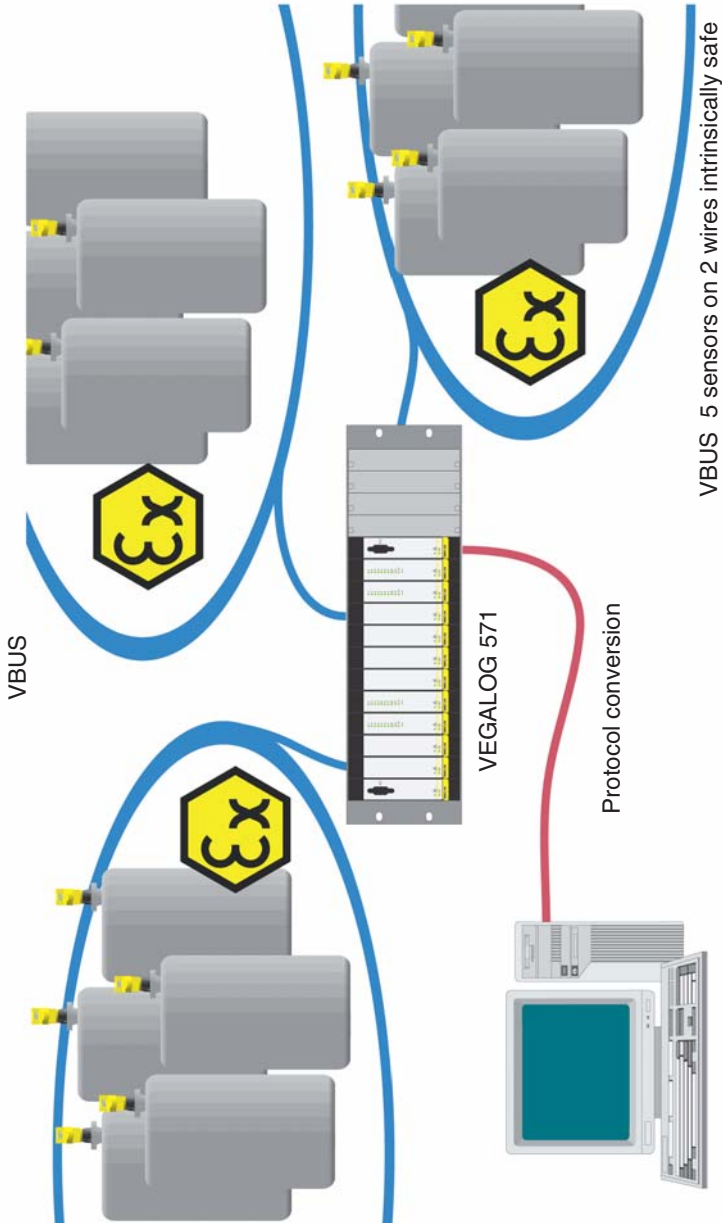

Fig 6.48

**h.** Fieldbus (VBUS), Ex ia intrinsically safe, multi-drop, 5 sensors on each two wire loop. 3 x 2 wire loops through 15 way isolator



*Fig 6.49*

## 6. Radar level installations

- i. Fieldbus (PROFIBUS PA), Ex ia intrinsically safe, 8 sensors on 2 wire loop, multi-drop, via segment coupler to PROFIBUS DP

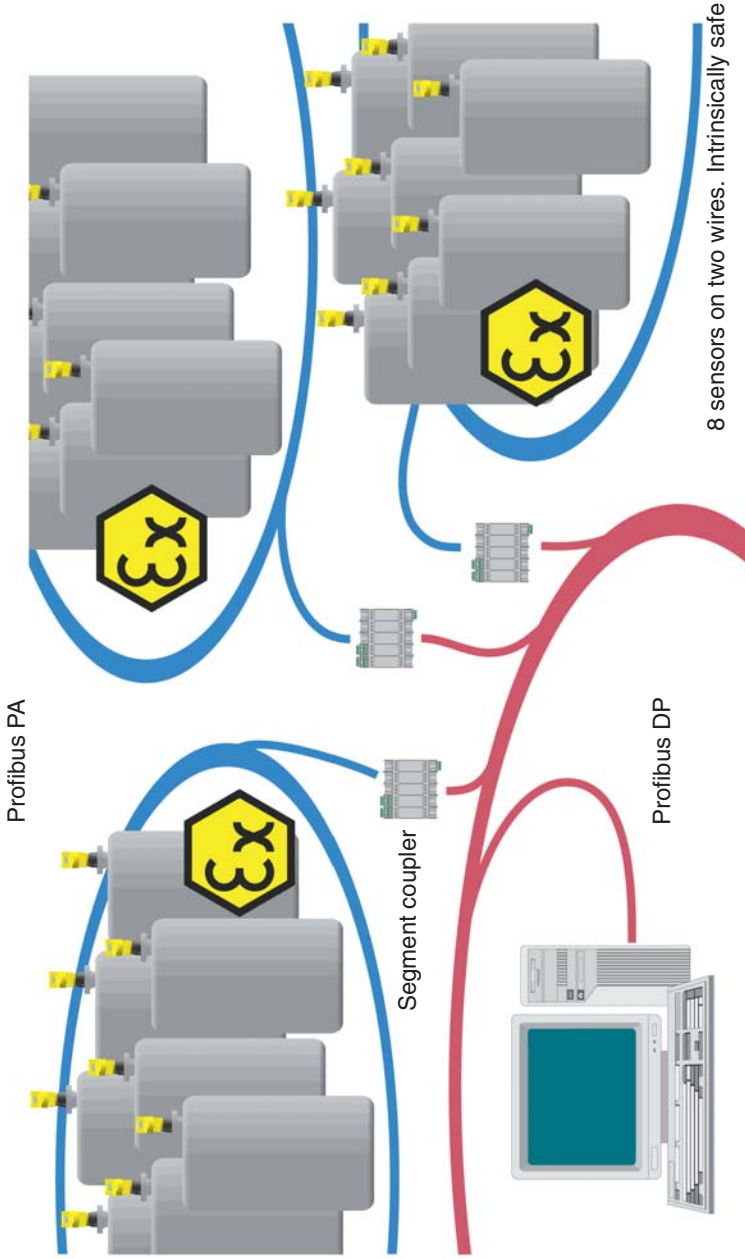

Fig 6.50



# **Part III**

Other level techniques  
Applications

