

**OHMART** **VEGA**



# ■ MiniTrac<sup>®</sup>

Radiation-Based Detector for Density  
and Point Level Measurement,  
4 ... 20 mA/HART four-wire

QUICK REFERENCE GUIDE



## Safety

Before attempting any wiring, make sure you read and understand all the instructions and safety guidelines in the **Operating Instructions** before operating the gauge. You must adhere to the country-specific installation standards and all prevailing safety regulations and accident prevention rules.

Regulatory agencies throughout the world have different requirements, regulations, and restrictions with respect to the use of nuclear instrumentation. Refer to the **Radiation Safety Manual** for more detailed safety information and instructions.

# Mounting

Measurement accuracy is highly influenced by the proper installation of the gauge. This section contains the guidelines for optimizing performance through proper installation. You may also reference the application sizing sheet and any installation drawings provided at the time of order.

## Preferred Orientation

The preferred orientation for the gauge is perpendicular to the process pipe.

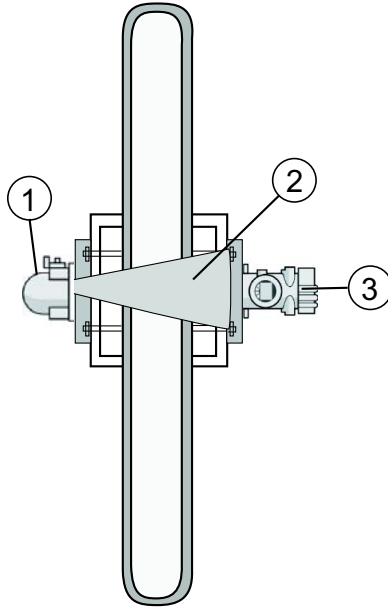

Figure 1: Preferred Orientation

- 1 Source Holder
- 2 Collimated Fan of Radiation
- 3 Detector

## Mounting Instructions

Mount the density gauge on the pipe by positioning the detector housing and the source holder brackets using the bolts provided by Ohmart/VEGA. If the pipe has insulation, make certain the density gauge and the source holder have external support so the insulation is not crushed.



The handle on the source holder operates a rotating shutter. When you are installing or removing the source holder from the pipe, make sure you turn the handle to the closed or OFF position and lock the handle. This action is not necessary if you have a low activity source holder.

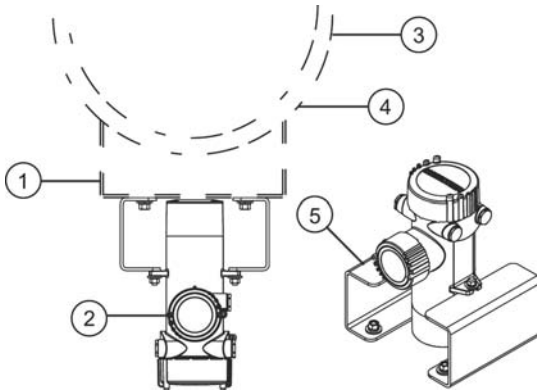

Figure 2: Mounting the Density Gauge

- 1 User's Mounting Bracket or PTB1 Mounting Bracket (Sold Separately)
- 2 Gauge
- 3 Vessel Wall
- 4 Insulation, if any
- 5 PTB4 Bracket (Sold Separately)

# Wiring

## Primary Chamber Connections

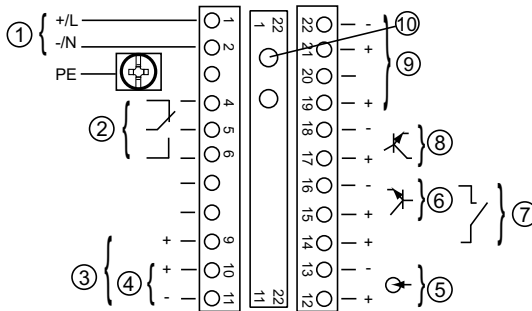

Figure 3: Primary Terminal Connections

- 1 Power Supply
- 2 Relay Output (4 = Normally Closed, 5 = Common, 6 = Normally Open)
- 3 4 ... 20 mA Active Output (Ex Proof Gauges Only, 9 = DC+, 11 = DC-)
- 4 4 ... 20 mA Passive Output (Ex Proof Gauges Only, 10 = DC+, 11 = DC-)
- 5 4 ... 20 mA Passive Input
- 6 Digital Input, 10 mA max.
- 7 Relay Input, 100 mA max. (14 = DC+, 16 = DC-)
- 8 Digital Output
- 9 Multi-gauge Communication (21 & 22 = Out, 19 & 20 = in)
- 10 Address Switches for Multi-gauge Systems

## Secondary Chamber Connections

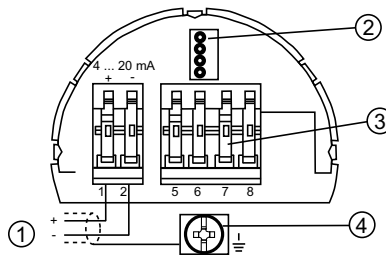

Figure 4: Secondary Terminal Connections

- 1 4 ... 20 mA Passive Output option (Intrinsically Safe Current Loop Output Option, Passive)
- 2 PLICSCOM Connection
- 3 Terminals 5, 6, 7, 8 (Intrinsically Safe Connections for Remote Display VEGADIS 61)
- 4 Ground Connection

# Setup and Adjustment

## Setup Procedures

Complete the following procedures in the order listed for the proper setup and operation of your gauge.

## Install PACTware

Install PACTware and the DTM by inserting the CD or double-clicking the autorun.exe and following the installation assistant.

## Connect to a Detector

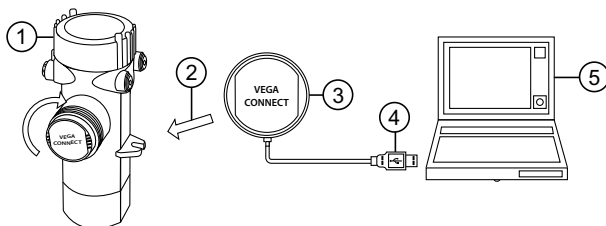

Figure 5: Direct Detector Connection

- 1 Detector
- 2 Press Module on Electronics and Turn Right (USB mini connector must face away from cover)
- 3 VEGACONNECT
- 4 USB Cable
- 5 PC with PACTware Software



See the **Operating Instructions** for additional options for connecting the gauge.

## Start PACTware

To open PACTware, click Windows **Start, All Programs, PACTware, PACTware** or double-click the PACTware shortcut on your desktop.

## Set up Project Tree

1. Open PACTware, if you have not already done so.
2. From the **Device** menu, click **Add device** or click the **Add device** icon from the PACTware toolbar.
3. From the **Device for** dialog box, click **VEGACONNECT 4**.
4. Click **OK**.
5. From the **Device** menu, click **Add device** or click the **Add device** icon from the PACTware toolbar.
6. From the **Device for** dialog box, click the DTM for your particular ProTrac device.

7. Click **OK**.
8. From the **Channel select** dialog box, click one of the following:
  - Click **I<sup>2</sup>C** if you are connecting directly to a detector
  - Click **HART** if you are using clips (alligator clips) to connect through the current output loop.
9. Click **OK**.
10. From the PACTware toolbar, click the **Connect** icon or right-click the detector from the left pane of the **PACTware** dialog box and click **Connect**.

## Setup Assistant

Use the **Setup Assistant** to complete the gauge setup.

1. Double-click the sensor in the **Project** window to open the device's DTM.
2. Type the measurement loop name in the **Measurement loop name** box.
3. In the **Isotope** list, click **Cs 137** or **Co 60** for your source isotope.
4. Click the **Start the setup assistant** button.

## Selection of the Application

Follow the steps below to select the application:

1. From the **Application** list, click the application you wish to use.
2. Click **Next**.

## Select Inputs

From the **Select inputs** dialog box, click **Next**.

## Background Radiation (Optional)

Follow the steps below to configure the gauge to subtract background pulses:

1. Close all radiation source shutters.
2. From the **Background radiation** dialog box, click **Measure background radiation** to determine the count rate and the amount of background radiation present.
3. Click **Next**.

## Adjustment

1. From the **Unit of process values** list, click the measurement unit you want to use.
2. In the **Max. process value** box, type the maximum process value you want to use.
3. In the **Min. process value** box, type the minimum process value you want to use.
4. Click **Next**.

## Tube Inside Diameter

Tube inside diameter is a measurement of the inner diameter of the process flow pipe. The system uses this value in the equation to calculate the actual linearization curve.

## Linearizer Data Points (Adjustment Steps)

Follow the steps below to add data points to your linearizer table when working online:



Make certain the counts you add are in increasing value and that you do not have an empty row in the linearizer table.

1. Set the process material to a known density and record the value.



Alternatively, you can sample and weigh the process and record the calculated density.

2. From the **Tube inside diameter** list, click the measurement value you wish to use.
3. Type the value of the pipe inner diameter in the **Tube inside diameter** box.
4. Click **Determine pulse rate**, if you want PACTware to automatically determine the **Pulse rate [ct/s]**.



When adding adjustment points to the linearizer table, make certain the process is stable before clicking **Determine pulse rate**. A **Note** dialog box appears with the pulse rate.

5. Click **OK**.
6. Type the value determined in Step 1 in the **Density** column next to the displayed pulse rate.
7. Click **Next**, if you wish accept the pulse rate and save the linearization.
8. Repeat steps 4 through 6 for each point in the linearizer table.

Follow the steps below to manually add pre-determined data points to your linearizer table:

1. Type a known value in the **Pulse rate [ct/s]** column.
2. Type a known value in the **Density** column next to the the displayed pulse rate.
3. Click **Next**, if you wish to accept the pulse rate and save the linearization.

If you wish to delete data points in your linearization table, complete the following steps:

1. Right-click a line in the **Pulse rate [ct/s]** and **Density** window.
2. Click **Delete line** to delete existing data points.
3. Click **Next**.

To re-order the data points in order of increasing pulse rate, complete the steps below:

1. Click the **Pulse rate[ct/s]** heading cell.
2. If the counts are displayed in decreasing order, click the heading cell again.
3. Click **Next**.

### Damping

To set the damping features, complete the following steps:

1. In the **Damping** dialog box, click the type of filter you wish to use from **Filter selection** list.
2. If you clicked **Automatically**, click **Next**.
3. If you clicked **Manually** from the **Filter selection** list, type the integration time in the **Integration time** box.
4. Click **Next**.

## Current Output

Set the **Current Output** with the following steps:

1. From the **Output characteristics** list, choose how you want the current output to track increasing density.
2. From the **Failure mode** list, choose the current you want to indicate alarm status.
3. From the Min. current list, click the value you wish to use.
4. From the Max. current list, click the value you wish to use.
5. Click **Next**.

## Relay

Configure the relay to indicate high electronics temperature or a high or low process using the relay setup.



The Upper and Lower Switch Settings are used to establish a "dead band" or hysteresis. The dead band is the point between the alarm activation and the point at which the alarm releases or deactivates.

To set the relay, complete the following steps:

1. From the **Basic value** list, click one of the following:
  - **None** - Click this value if you want the relay to indicate diagnostic faults only.
  - **Electronics temperature** - Click this value if you want the relay to indicate high electronics temperature and diagnostic faults.
  - **Process value** - Click this value if you want the relay to indicate a high or low process value and diagnostic faults.

If you clicked **None**, the **Failure mode** is off.

1. Click **Next**.
2. Click **Finish** to complete the **Setup assistant** and save the data to the gauge.

If you clicked **Electronics temperature** from the **Basic value** list, complete the following:

1. From the **Temperature unit** list, click °C or °F.
2. In the **Upper switching point (S2)** box, type an upper switching point value.
3. In the **Lower switching point (S1)** box, type a lower switching point value.
4. Click **Next**.
5. Click **Finish** to complete the **Setup assistant** and save the data to the gauge.

If you clicked **Process value** from the **Basic value** list, complete the following:

1. From the **Mode of operation** list, click **Overfill protection** or **Dry run protection**.
2. In the **Upper switching point (S2)** box, type an upper switching point value.
3. In the **Lower switching point (S1)** box, type a lower switching point value.
4. Click **Next**.
5. Click **Finish** to complete the **Setup assistant** and save the data to the gauge.

# Maintenance and Diagnostics

## Periodic Maintenance Schedule

| Description                 | Frequency   | Procedure   |
|-----------------------------|---|---|
| Standardize                 | As required by process conditions, usually at least once every six months           | Follow the steps listed in <b>Real Value Correction</b> to standardize the gauge.   |
| Source holder shutter check | Every six months unless otherwise required by applicable nuclear regulatory agency  | Check the radiation safety instructions shipped separately with your source holder. |
| Source wipe                 | Every three years unless otherwise required by applicable nuclear regulatory agency | Check the radiation safety instructions shipped separately with your source holder. |

## Troubleshooting

If your gauge displays an error, refer to the following table for assistance.

| Value | DTM Text  | Event Description                          |
|-------|---|--|
| F008  | Error multisensor communication                           | Communication error                        |
| F013  | Sensor signals failure                                    | Sensor input out of range                  |
| F016  | Adjustment data exchanged                                 | Adjustment data is exchanged               |
| F017  | Adjusted span too small                                   | Adjustment span too small                  |
| F025  | Invalid linearizer table                                  | Invalid linearizer table                   |
| F030  | Process value not within the limits                       | Measurement value invalid                  |
| F034  | EEPROM hardware error                                     | EEPROM failure                             |
| F035  | EEPROM data error   | Corrupt EEPROM                             |
| F036  | Error in the program memory                               | Corrupt program memory                     |
| F037  | RAM hardware error  | RAM failure                                |
| F038  | Slave signals failure                                     | Network gauge response error               |
| F040  | Hardware error  | Hardware error                             |
| F041  | Photomultiplier error                                     | No sensor connected                        |
| F045  | Error in the current output                               | Current loop error                         |
| F052  | Faulty configuration of the multisensor communication bus | Gauge configuration error, consult factory |
| F053  | Adjustment span of the input too small                    | Span in EB too small                       |
| F057  | Error in the linearization table for the input instrument | Input device linearizer table error        |

| Value | DTM Text   | Event Description                  |
|-------|--|------------------------------------|
| F059  | Faulty adjustment of the steam density compensation          | Configuration Error                |
| F066  | Faulty adjustment  | Adjustment out of bounds           |
| F068  | Counting rate too high                                       | Error in measurement               |
| F072  | Limit value exceeded   | Limit Exceeded                     |
| F073  | Error real value correction                                  | Standardization error              |
| F080  | System failure   | System error, contact factory.     |
| F086  | Communication error  | Network error                      |
| F120  | Filter time failure  | Filter time error, consult factory |
| F121  | Faulty participant list on the multisensor communication bus | MGC configuration error            |
| F122  | Double addresses on the multisensor communication bus        | Duplicate MGC addresses            |
| F123  | X-ray alarm  | X-ray interference                 |
| F124  | Excessive field alarm  | Excessive radiation alarm          |
| F125  | Ambient temperature too high                                 | Gauge temperature error            |
| F126  | Trend data failure   | Trend data error                   |
| F127  | Trend execution error  | Error while trend processing       |

# Customer Service

## U.S., Canada, and Worldwide

| Contact Information  | Telephone Number/E-mail Address |
|--|---------------------------------|
| Monday through Friday 8:00 A.M. - 5:00 P.M.<br>EST (Eastern Standard Time) | 1-513-272-0131                  |
| Emergencies: Follow the voice mail instructions                            | 1-513-272-0131                  |
| Fax  | 1-513-272-0133                  |
| VEGA 24 hour Service, 7 Days a Week  | +49 1805 858550                 |
| Field Service e-mail   | fieldservice@ohmartvega.com     |
| Nuclear Services e-mail  | nuclearservices@ohmartvega.com  |







## **OHMART** **VEGA**

4170 Rosslyn Drive  
Cincinnati, Ohio 45209 USA  
telephone: 1.513.272.0131  
fax: 1.513.272.0133  
web: [www.ohmartvega.com](http://www.ohmartvega.com)  
e-mail: [info@ohmartvega.com](mailto:info@ohmartvega.com)