

Flansch/flange		D	b	k	d
gez./draw.					
DIN2501/EN1092-1					
DN50	PN40	ø165	20	ø125	4xø18
DN80	PN40	ø200	24	ø160	8xø18
DN100	PN16	ø220	20	ø180	8xø18
DN150	PN16	ø285	22	ø240	8xø22
ASME B 16.5					
ASME 2"	150 RF	ø152,4	19,1	ø120,7	4xø19,1
ASME 2"	300 RF	ø165,1	22,4	ø127	8xø19,1
ASME 2½"	150 RF	ø177,8	22,4	ø139,7	4xø19,1
ASME 2½"	300 RF	ø190,5	25,4	ø149,4	8xø22,4
ASME 2½"	600 RF	ø190,5	34,8	ø149,4	8xø22,4
ASME 3"	150 RF	ø190,5	23,9	ø152,4	4xø19,1
ASME 3"	300 RF	ø209,5	28,4	ø168,1	8xø22,4
ASME 4"	150 RF	ø228,6	23,9	ø190,5	8xø19,1
ASME 4"	300 RF	ø254	31,8	ø200,2	8xø22,4
JIS B 2220					
DN50	10K RF	ø155	16	ø120	4xø19
DN80	10K RF	ø185	18	ø150	8xø19
DN100	10K RF	ø210	18	ø175	8xø19

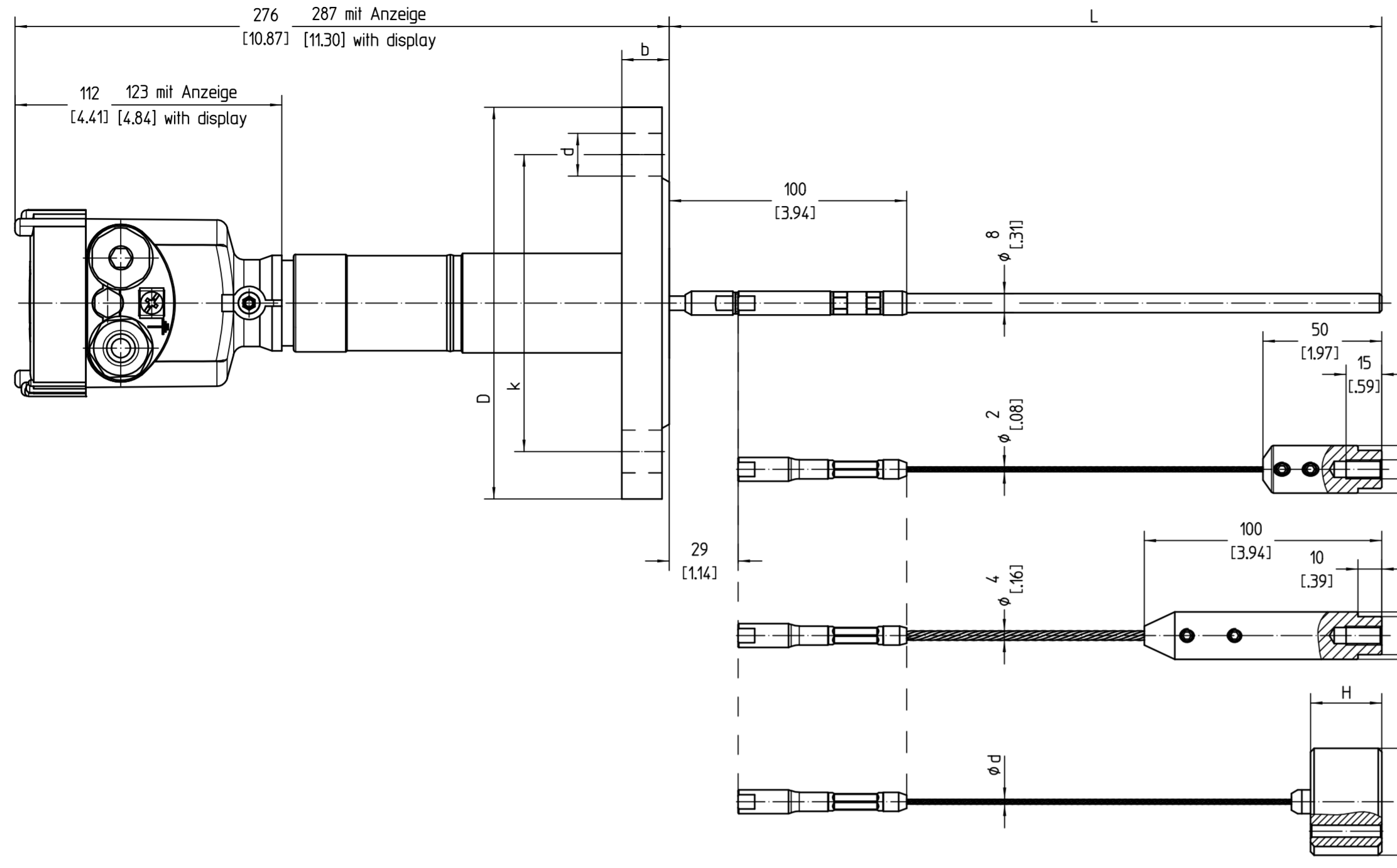

Seil ø2 / ø4 mit wechselbarem Zentriergewicht
rope ø2 / ø4 with changeable centring weight

ød = ø2 [0.08]		ød = ø4 [0.16]	
øD	H	øD	H
40 [1.57]	30 [1.18]	40 [1.57]	30 [1.18]
40 [1.57]	90 [3.54]	45 [1.77]	30 [1.18]
45 [1.77]	30 [1.18]	70 [2.76]	30 [1.18]
45 [1.77]	90 [3.54]	75 [2.95]	30 [1.18]
70 [2.76]	30 [1.18]	95 [3.74]	30 [1.18]
70 [2.76]	60 [2.36]	145 [5.71]	30 [1.18]
75 [2.95]	30 [1.18]	195 [7.68]	30 [1.18]
95 [3.74]	30 [1.18]		
145 [5.71]	30 [1.18]		
195 [7.68]	30 [1.18]		

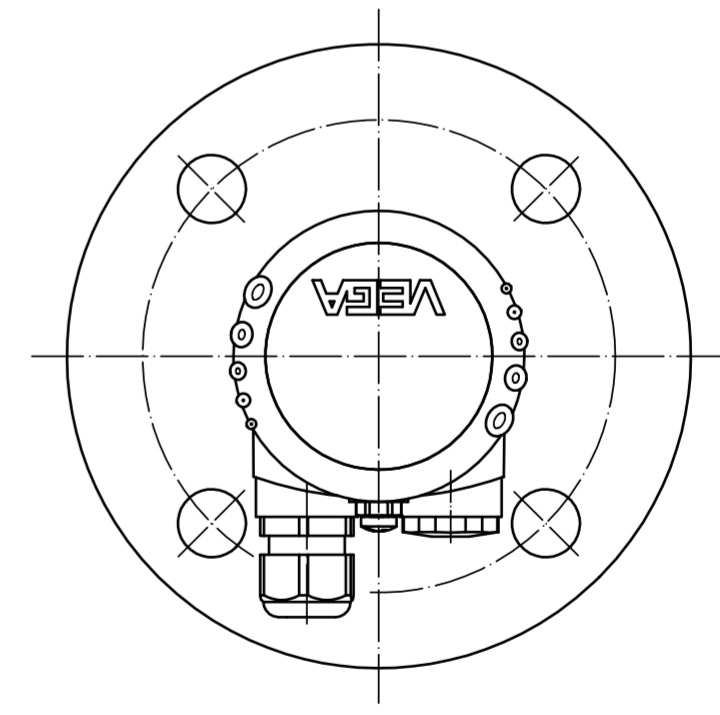
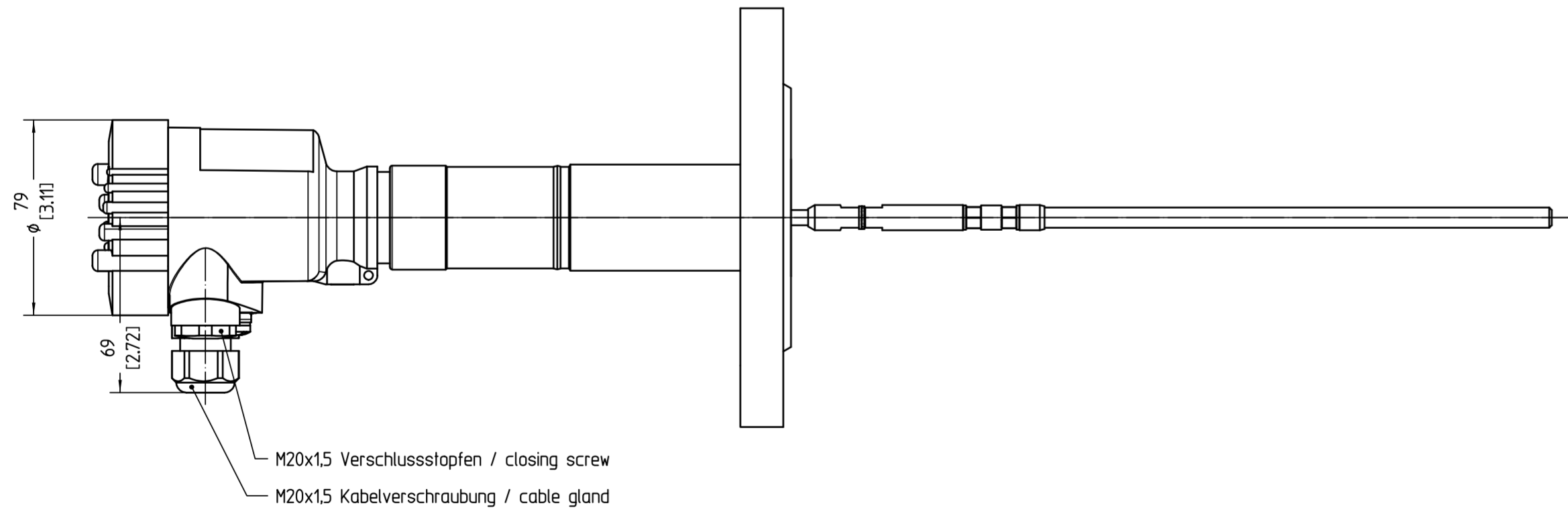

Diese Zeichnung bleibt Eigentum der Firma VEGA-Grieshaber KG. Sie darf ohne unsere Genehmigung weder kopiert, noch 3. Personen oder Konkurrenzfirmen mitgeteilt werden. (§ 2 Abs.1 Ziff.7 UrHG vom 09.09.1965)

Passmaß/tol.dimens.	Abmaß/allowance	Änderung / revision			Änd. Nr. / Rev. no.	Datum / Date	gezeichnet / freigegeben / drawn / checked
	Freimaß/tolerance general tolerance	gezeichnet / drawn / checked	Datum / Date	Name / Name	Benennung		Description
		28.10.2014	harlers	FLEX86 250°C Stab ø8, Seil ø2 und ø4, Flanschversion Ku.-Geh.	FLEX86 250°C rod ø8, rope ø2 and ø4, flange version pl.-haus.		
Werkstoff / Material	Maßstab / Scale 1:2	Originalformat / size of origin A2		Blatt / Sheet 1 of 1		VEGA VEGA Grieshaber KG Postfach 1142 77737 Schlitzbach Germany	
		Art.Nr. / Art.No. MB6466		Zchngs.-Nr. / Drawing No. MB6466		And.-Zust. / Rev. -	
		Var.Fam.: FX86-XXXDD3XXKMXX		Var.Fam.2:		Teil ähnl. / sim. part MB6459	
		Arb.Anw. / workinstr.		Ersatz f./replacement f.		Alle Maße in mm!	