



Safety instructions

VEGABAR B8*.CC/U/O/H/T

VEGABAR B8*.VC

CSA 70015745

Intrinsically Safe CL I, Div 1, GP ABCD;

Ex ia IIC T6 ... T1 Ga; CL I Zone 0, 0/1, 1 AEx ia
IIC T6 ... T1 Ga



Document ID: 50609



VEGA

Contents

1	Area of applicability	3
2	General information	3
3	Technical data	4
3.1	VEGABAR B8* with integrated electronics Z (4 ... 20 mA), H (4 ... 20 mA/HART) or A (4 ... 20 mA/HART with SIL qualification).....	4
3.2	VEGABAR B8* with integrated electronics P (Profibus PA), F (Foundation Fieldbus).....	7
3.3	VEGABAR B8* with integrated electronics S or T, only version with single chamber housing	11
3.4	VEGABAR B8*.CC/U/O/H/T, VEGABAR B8*.VC Version with separate cable outlet.....	11
4	Application conditions	11
5	Protection against static electricity	14
6	Use of an overvoltage arrester	14
7	Grounding	14
8	Impact and friction sparks	15
9	Material resistance	15
10	Mounting with external indicating unit VEGADIS 81	15
11	Installation/mounting	15
12	Installation of the VEGABAR B8*.CC/U/O/H/T, VEGABAR B8*.VC with separate housing.. 15	
13	Installation Diagram	15

Supplementary documentation:

- Operating Instructions VEGABAR 81, 82, 83, 86, 87
- Certificate of Conformity CSA 70015745 (Document ID: 50601)

Editing status: 2025-11-18

1 Area of applicability

These safety instructions apply to the pressure transmitters VEGABAR B81/82/83/86/87.CC/U/O/H/T and VEGABAR B81/82/83/86/87.VC with integrated electronics Z (4 ... 20 mA), H (4 ... 20 mA/HART), A (4 ... 20 mA/HART with SIL qualification), S, T (differential pressure measurement), P (Profibus PA), F (Foundation Fieldbus) without supplementary electronics (X) according to Certificate of Conformity CSA 70015745 (certificate number on the type label) and for all instruments with the number of the safety instruction (50609) on the type label.

2 General information

The pressure-based measuring instruments VEGABAR B8*.CC/U/O/H/T, VEGABAR B8*.VC are also used for pressure and level measurement in hazardous areas.

The measured products can also be combustible liquids, gases, mist or vapour or Dust (Division application only).

The VEGABAR B8*.CC/U/O/H/T, VEGABAR B8*.VC consist of an electronics housing with integrated electronics module, a process connection element and a sensor, the pressure measuring cell with optionally connected chemical seal. As an option, the display and adjustment module can also be mounted.

The VEGABAR B8*.CC/U/O/H/T, VEGABAR B8*.VC are suitable for use in hazardous atmospheres of all combustible materials of explosion group A, B, C, D, E, F, G for applications requiring Class I, II, III, Div 1 instruments or of explosion groups IIA, IIB, IIC for applications requiring Class I, Zone 0, 0/1, 1 AEx ia IIC T6, Ga, Gb or Ex ia IIC T6 ... T1 Ga instruments.

If the VEGABAR B8*.CC/U/O/H/T, VEGABAR B8*.VC are installed and operated in hazardous areas, the general Ex installation regulations in the Canadian Electrical Code/National Electrical Code, IEC 60079-14 as well as these safety instructions must be observed.

The operating instructions as well as the installation regulations and standards that apply for explosion protection of electrical systems must always be observed.

The installation of explosion-endangered systems must always be carried out by qualified personnel.

Hazardous locations designation

Intrinsically safe

CL I, Div 1, GP ABCD;

Ex ia IIC T6 ... T1 Ga

CL I Zone 0, 0/1, 1 AEx ia IIC T6 ... T1 Ga

3 Technical data

3.1 VEGABAR B8* with integrated electronics Z (4 ... 20 mA), H (4 ... 20 mA/HART) or A (4 ... 20 mA/HART with SIL qualification)

Electrical data

VEGABAR B8*.CC/U/O/H/T, VEGABAR B8*.VC with integrated electronics Z (4 ... 20 mA), H (4 ... 20 mA/HART) or A (4 ... 20 mA/HART with SIL qualification), version with single chamber housing A, K, V or 8

Supply and signal circuit: (terminals 1[+], 2[-] in the "Ex-i" electronics compartment or plug connection) In ignition protection type intrinsic safety Ex ia IIC/IIB
Only for connection to a certified, intrinsically safe circuit.

Maximum values:

- $U_i = 30 \text{ V}$
- $I_i = 131 \text{ mA}$
- $P_i = 983 \text{ mW}$

The effective internal capacitance C_i is negligibly small.

In the version with permanently mounted connection cable, $C_{i \text{ wire/wire}} = 150 \text{ pF/m}$ and $C_{i \text{ wire/screen}} = 270 \text{ pF/m}$ must be taken into account.

The effective inner inductance L_i is $L_i \leq 5 \text{ }\mu\text{H}$. In the version with permanently mounted connection cable, $L_i = 0.62 \text{ }\mu\text{H/m}$ must also be taken into account.

VEGABAR B8*.CC/U/O/H/T, VEGABAR B8*.VC with integrated electronics Z (4 ... 20 mA), H (4 ... 20 mA/HART) or A (4 ... 20 mA/HART with SIL qualification), version with double chamber housing D, W or R

Power supply and signal circuit: (terminal 1[+], 2[-] in the "Ex-i" connection compartment) In ignition protection type intrinsic safety Ex ia IIC/IIB
Only for connection to a certified, intrinsically safe circuit.

Maximum values:

- $U_i = 30 \text{ V}$
- $I_i = 131 \text{ mA}$
- $P_i = 983 \text{ mW}$

The effective internal capacitance C_i is negligibly small.

In the version with permanently mounted connection cable, $C_{i \text{ wire/wire}} = 150 \text{ pF/m}$ and $C_{i \text{ wire/screen}} = 270 \text{ pF/m}$ must be taken into account.

The effective inner inductance L_i with the double chamber version is $L_i \leq 10 \text{ }\mu\text{H}$. In the version with permanently mounted connection cable, $L_i = 0.62 \text{ }\mu\text{H/m}$ must also be taken into account.

VEGABAR B8*.CC/U/O/H/T, VEGABAR B8*.VC with integrated electronics Z (4 ... 20 mA), H (4 ... 20 mA/HART) or A (4 ... 20 mA/HART with SIL qualification)

Indicating and adjustment circuit: (terminals 5, 6, 7, 8)¹⁾²⁾³⁾

In ignition protection type intrinsic safety Ex ia IIC

For connection to the intrinsically safe circuit of the corresponding external display unit VEGADIS 81 or for connection of a VEGABAR B80 with integrated electronics S or T for differential pressure measurement.

The rules for the interconnection of intrinsically safe circuits between VEGABAR B8*.CC/U/O/H/T, VEGABAR B8*.VC and the external indicating unit VEGADIS 81 or VEGABAR B8* with electronics S or T are fulfilled, provided that the total inductance and total capacitance of the connection cable between VEGABAR B8*.CC/U/O/H/T, VEGABAR B8*.VC and the external indicating unit VEGADIS 81 or VEGABAR B8* with electronics S or T $L_{\text{cable}} = 330 \mu\text{H}$ and $C_{\text{cable}} = 1.98 \mu\text{F}$ are not exceeded.

When using the delivered VEGA connection cable between VEGABAR B8*.CC/U/O/H/T, VEGABAR B8*.VC and the external indicating unit VEGADIS 81 or VEGABAR B8* with electronics S or T, the following listed cable inductances L_i and cable capacitances C_i must be taken into account with a cable length $\geq 50 \text{ m}$.

- $L_i = 0.62 \mu\text{H/m}$
- $C_{i \text{ wire/wire}} = 150 \text{ pF/m}$
- $C_{i \text{ wire/screen}} = 270 \text{ pF/m}$

Intrinsically safe circuit for the display and adjustment module

VEGABAR B8*.CC/U/O/H/T, VEGABAR B8*.VC with integrated electronics Z (4 ... 20 mA), H (4 ... 20 mA/HART) or A (4 ... 20 mA/HART with SIL qualification), version with single chamber housing A, K, V or 8

Circuit for the display and adjustment module: (spring contacts in the "Ex-ii" electronics compartment)

In ignition protection type intrinsic safety Ex ia IIC

For connection to the display and adjustment module PLICSCOM.

- 1) In the "Ex-i" electronics compartment with VEGABAR in version with single chamber housing A, K, V or 8.
- 2) In the "Ex-i" connection compartment with VEGABAR in version with double chamber housing D, W or R.
- 3) Additional plug connection with VEGABAR in version with double chamber housing D, W, R and housing version/protection P (with M12 x 1 for VEGADIS).

VEGABAR B8*.CC/U/O/H/T, VEGABAR B8*.VC with integrated electronics Z (4 ... 20 mA), H (4 ... 20 mA/HART) or A (4 ... 20 mA/HART with SIL qualification), version with double chamber housing D, W or R

Circuit for the display and adjustment module: (spring contacts in the "Ex-i" connection compartment)

In ignition protection type intrinsic safety Ex ia IIC
For connection to the display and adjustment module PLICSCOM.

or

Circuit for the display and adjustment module: (spring contacts in the "Ex-i" electronics compartment)

In ignition protection type intrinsic safety Ex ia IIC
For connection to the display and adjustment module PLICSCOM.

In the double chamber version, the display and adjustment module PLICSCOM must only be equipped in the connection compartment, if there is no external VEGA display unit VEGADIS 81 or VEGABAR B80 with electronics S, T connected.

VEGABAR B8*.CC/U/O/H/T, VEGABAR B8*.VC with integrated electronics Z (4 ... 20 mA), H (4 ... 20 mA/HART) or A (4 ... 20 mA/HART with SIL qualification), version with double chamber housing D, W or R with housing version/protection P (with M12 x 1 for VEGADIS)

Circuit for the display and adjustment module: (spring contacts in the "Ex-i" connection compartment)

In ignition protection type intrinsic safety Ex ia IIC
For connection to the display and adjustment module PLICSCOM.

In the double chamber version, the display and adjustment module PLICSCOM must only be equipped in the connection compartment, if there is no external VEGA display unit VEGADIS 81 or VEGABAR B80 with electronics S, T connected.

3.2 VEGABAR B8* with integrated electronics P (Profibus PA), F (Foundation Fieldbus)

VEGABAR B8*.CC/U/O/H/T, VEGABAR B8*.VC with integrated electronics P (Profibus PA), F (Foundation Fieldbus), version with single chamber housing A, K, V or 8

Supply and signal circuit: (terminals 1[+], 2[-] in the "Ex-i" electronics compartment or plug connection) In ignition protection type intrinsic safety Ex ia IIC
Only for connection to a certified, intrinsically safe circuit.

Maximum values:

- $U_i = 17.5 \text{ V}$
- $I_i = 500 \text{ mA}$
- $P_i = 5.5 \text{ W}$

The instrument is suitable for connection to a Fieldbus system according to the FISCO model (IEC 60079-11), e.g. Profibus PA.

or

- $U_i = 24 \text{ V}$
- $I_i = 250 \text{ mA}$
- $P_i = 1.2 \text{ W}$

The effective internal capacitance C_i is negligibly small.

The effective internal inductance L_i is negligibly small.

In the version with fix-mounted connection cable, the following cable inductances L_i' and cable capacitances C_i have to be taken into account.

- $L_i = 0.62 \text{ } \mu\text{H/m}$
- $C_{i \text{ wire/wire}} = 150 \text{ pF/m}$
- $C_{i \text{ wire/screen}} = 270 \text{ pF/m}$

VEGABAR B8*.CC/U/O/H/T, VEGABAR B8*.VC with integrated electronics P (Profibus PA), F (Foundation Fieldbus), version with double chamber housing D, W or R

Power supply and signal circuit: (terminal 1[+], 2[-] in the "Ex-i" connection compartment)

In ignition protection type intrinsic safety Ex ia IIC

Only for connection to a certified, intrinsically safe circuit.

Maximum values:

- $U_i = 17.5 \text{ V}$
- $I_i = 500 \text{ mA}$
- $P_i = 5.5 \text{ W}$

The instrument is suitable for connection to a Fieldbus system according to the FISCO model (IEC 60079-11), e.g. Profibus PA.

or

- $U_i = 24 \text{ V}$
- $I_i = 250 \text{ mA}$
- $P_i = 1.2 \text{ W}$

The effective internal capacitance C_i is negligibly small.

The effective internal inductance is $L_i \leq 5 \mu\text{H}$.

In the version with fix-mounted connection cable, the following cable inductances L_i' and cable capacitances C_i have to be taken into account.

- $L_i = 0.62 \mu\text{H/m}$
- $C_{i \text{ wire/wire}} = 150 \text{ pF/m}$
- $C_{i \text{ wire/screen}} = 270 \text{ pF/m}$

VEGABAR B8*.CC/U/O/H/T, VEGABAR B8*.VC with integrated electronics P (Profibus PA), F (Foundation Fieldbus)

Indicating and adjustment circuit: (terminals 5, 6, 7, 8)⁴⁾⁵⁾⁶⁾

In ignition protection type intrinsic safety Ex ia IIC

For connection to the intrinsically safe circuit of the corresponding external display unit VEGADIS 81 or for connection of a VEGABAR B80 with integrated electronics S or T for differential pressure measurement.

The rules for the interconnection of intrinsically safe circuits between VEGABAR B8*.CC/U/O/H/T, VEGABAR B8*.VC and the external indicating unit VEGADIS 81 or VEGABAR B8* with electronics S or T are fulfilled, provided that the total inductance and total capacitance of the connection cable between VEGABAR B8*.CC/U/O/H/T, VEGABAR B8*.VC and the external indicating unit VEGADIS 81 or VEGABAR B8* with electronics S or T are not exceeded.

- $L_{\text{cable}} = 212 \mu\text{H}$
- $C_{\text{cable}} = 1.98 \mu\text{F}$

When using the delivered VEGA connection cable between VEGABAR B8*.CC/U/O/H/T, VEGABAR B8*.VC and the external indicating unit VEGADIS 81 or VEGABAR B8* with electronics S or T, the following listed cable inductances L_1 and cable capacitances C_1 must be taken into account with a cable length ≥ 50 m.

- $L_1 = 0.62 \mu\text{H/m}$
- $C_{1 \text{ wire/wire}} = 150 \text{ pF/m}$
- $C_{1 \text{ wire/screen}} = 270 \text{ pF/m}$

VEGABAR B8*.CC/U/O/H/T, VEGABAR B8*.VC with integrated electronics P (Profibus PA), F (Foundation Fieldbus), version with single chamber housing A, K, V or 8

Circuit for the display and adjustment module: (spring contacts in the "Ex-i" electronics compartment)

In ignition protection type intrinsic safety Ex ia IIC

For connection to the display and adjustment module PLICSCOM.

- 4) In the "Ex-i" electronics compartment with VEGABAR in version with single chamber housing A, K, V or 8.
- 5) In the "Ex-i" connection compartment with VEGABAR in version with double chamber housing D, W or R.
- 6) Additional plug connection with VEGABAR in version with double chamber housing D, W, R and housing version/protection P (with M12 x 1 for VEGADIS).

VEGABAR B8*.CC/U/O/H/T, VEGABAR B8*.VC with integrated electronics P (Profibus PA), F (Foundation Fieldbus), version with double chamber housing D, W or R

Circuit for the display and adjustment module: (spring contacts in the "Ex-i" connection compartment)

In ignition protection type intrinsic safety Ex ia IIC
For connection to the display and adjustment module PLICSCOM.

or

Circuit for the display and adjustment module: (spring contacts in the "Ex-i" electronics compartment)

In ignition protection type intrinsic safety Ex ia IIC
For connection to the display and adjustment module PLICSCOM.

In the double chamber version, the display and adjustment module PLICSCOM must only be equipped in the connection compartment, if there is no external VEGA display unit VEGADIS 81 or VEGABAR B80 with electronics S, T connected.

VEGABAR B8*.CC/U/O/H/T, VEGABAR B8*.VC with integrated electronics Z (4 ... 20 mA), H (4 ... 20 mA/HART) or A (4 ... 20 mA/HART with SIL qualification), version with double chamber housing D, W or R with housing version/protection P (with M12 x 1 for VEGADIS)

Circuit for the display and adjustment module: (spring contacts in the "Ex-i" connection compartment)

In ignition protection type intrinsic safety Ex ia IIC
For connection to the display and adjustment module PLICSCOM.

In the double chamber version, the display and adjustment module PLICSCOM must only be equipped in the connection compartment, if there is no external VEGA display unit VEGADIS 81 or VEGABAR B80 with electronics S, T connected.

3.3 VEGABAR B8* with integrated electronics S or T, only version with single chamber housing

VEGABAR B8*.CC/U/O/H/T, VEGABAR B8*.VC with integrated electronics S or T, only version with single chamber housing

Power supply and signal circuit: (terminals 5, 6, 7, 8 in the electronics compartment)

In ignition protection type intrinsic safety Ex ia IIC

For connection to the intrinsically safe circuit of a VEGABAR B8*.C***** with integrated electronics H, A, P, F for differential pressure measurement.

The rules for the interconnection of intrinsically safe circuits between VEGABAR B80 with electronics S or T and VEGABAR B8*.C***** are fulfilled, provided that the total inductance and total capacitance of the connection cable between VEGABAR B8*.C***** and VEGABAR B8* with electronics S or T, $L_{\text{cable}} = 330 \mu\text{H}$ and $C_{\text{cable}} = 2.00 \mu\text{F}$, is not exceeded.

When using the delivered VEGA connection cable between VEGABAR B8*.CC/U/O/H/T, VEGABAR B8*.VC and the external indicating unit VEGADIS 81 or VEGABAR B8* with electronics S or T, the following listed cable inductances L_i and cable capacitances C_i must be taken into account with a cable length $\geq 50 \text{ m}$.

- $L_i = 0.62 \mu\text{H/m}$
- $C_{i \text{ wire/wire}} = 150 \text{ pF/m}$
- $C_{i \text{ wire/screen}} = 270 \text{ pF/m}$

3.4 VEGABAR B8*.CC/U/O/H/T, VEGABAR B8*.VC Version with separate cable outlet

VEGABAR B8*.CC/U/O/H/T, VEGABAR B8*.VC Version with separate cable outlet

Circuit between sensor unit and external electronics (terminal 1- yellow, terminal 2 - white, terminal 3 - red, terminal 4 - black)

In ignition protection type intrinsic safety

With VEGABAR B8*.AC in the version with fix mounted cable on the sensor unit and external electronics, the supplied cable between the external housing and the sensor unit must not exceed a length of 180 m.

The intrinsically safe circuits for external connections are electrically separated from parts which can be grounded.

The intrinsically safe circuits to the sensor are galvanically connected to ground potential.

The metallic parts of VEGABAR B8*.CC/U/O/H/T, VEGABAR B8*.VC are electrically connected with the earth terminals.

VEGABAR B8*.CC/U/O/H/T, VEGABAR B8*.VC is preferably connected to appropriate instruments with electrically isolated, intrinsically safe circuits.

4 Application conditions

VEGABAR B8*.CC/U/O/H/T, VEGABAR B8*.VC with integrated electronics Z (4 ... 20 mA), H (4 ... 20 mA/HART) or A (4 ... 20 mA/HART with SIL qualification), S, T (electronic differential pressure measurement), P (Profibus PA), F (Foundation Fieldbus)

The max. permissible ambient temperatures depending on the temperature classes are specified in

the following tables.

Class I, Zone 0 application

Temperature class	Ambient temperature on the sensor and electronics
T6	-20 ... +23 °C
T5, T4, T3, T2, T1	-20 ... +60 °C

For applications requiring instruments of Class I, Zone 0 the process pressure of the media must be between 0.8 ... 1.1 bar. The application conditions when operating in the absence of explosive mixtures can be found in the manufacturer information.

Class I, Zone 0/1 application

Temperature class	Ambient temperature on the electronics	Product temperature on the sensor
T6	-50 ... +39 °C	-20 ... +23 °C
T5, T4, T3, T2, T1	-50 ... +70 °C	-20 ... +60 °C

For applications requiring instruments of Class I, Zone 0/1 the process pressure of the media must be between 0.8 ... 1.1 bar. If the VEGABAR B8*.CC/U/O/H/T, VEGABAR B8*.VC are operated at temperatures higher than those specified in the above table, please make sure through appropriate measures that there is no danger of ignition from the hot surfaces. The maximum temperature on the electronics/housing should not exceed the values specified in the above table. The application conditions during operation in areas with no explosive mixtures are stated in the manufacturer information.

Class I, II, III, Div 1 applications, Class I, Zone 1, applications: VEGABAR 82, VEGABAR 83 with METEC measuring cell

Temperature class	Ambient temperature on the electronics (Zone 1)	Product temperature range (sensor, zone 1)
T6	-50 ... +39 °C	-50 ... +39 °C
T5	-50 ... +70 °C	-50 ... +100 °C
T4	-50 ... +50 °C	-50 ... +135 °C
T3, T2, T1	-50 ... +50 °C	-50 ... +200 °C

Class I, II, III, Div 1 applications, Class I, Zone 1, applications: VEGABAR 83 version with piezoresistive/strain gauge measuring cell, version without cooling element

Temperature class	Ambient temperature on the electronics (Zone 1)	Product temperature range (sensor, zone 1)
T6	-50 ... +39 °C	-50 ... +39 °C
T5	-50 ... +70 °C	-50 ... +85 °C
T4	-50 ... +40 °C	-50 ... +105 °C
T4, T3, T2, T1	-50 ... +30 °C	-50 ... +120 °C

Class I, II, III, Div 1 applications, Class I, Zone 1, applications: VEGABAR 81, VEGABAR 83 version with piezoresistive/strain gauge measuring cell, version with cooling element

Temperature class	Ambient temperature on the electronics (Zone 1)	Product temperature range (sensor, zone 1)
T6	-50 ... +39 °C	-50 ... +39 °C
T5	-50 ... +70 °C	-50 ... +85 °C
T4	-50 ... +50 °C	-50 ... +120 °C
T3, T2, T1	-50 ... +40 °C	-50 ... +150 °C

If the VEGABAR B8*.CC/U/O/H/T, VEGABAR B8*.VC are operated at temperatures higher than those specified in the above table, please make sure through appropriate measures that there is no danger of ignition from the hot surfaces. The max. permissible temperature on the electronics/housing should not exceed the values specified in the above table. The application conditions during operation with no explosive mixtures present are stated in the manufacturer information.

Temperature derating

VEGABAR 82, version process temperature +130 °C

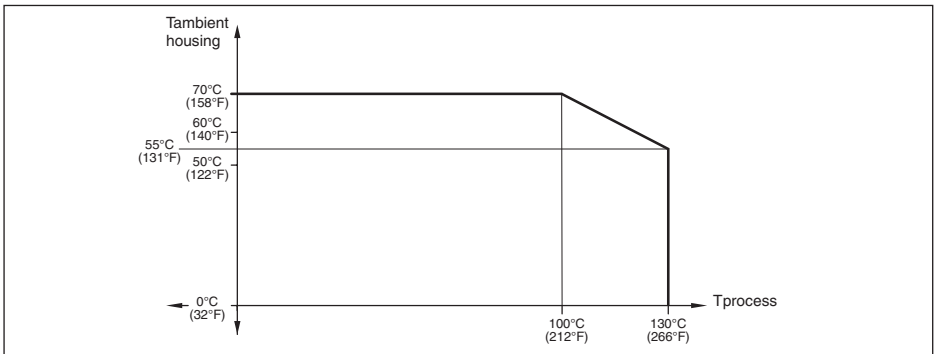

VEGABAR 82, version process temperature +150 °C

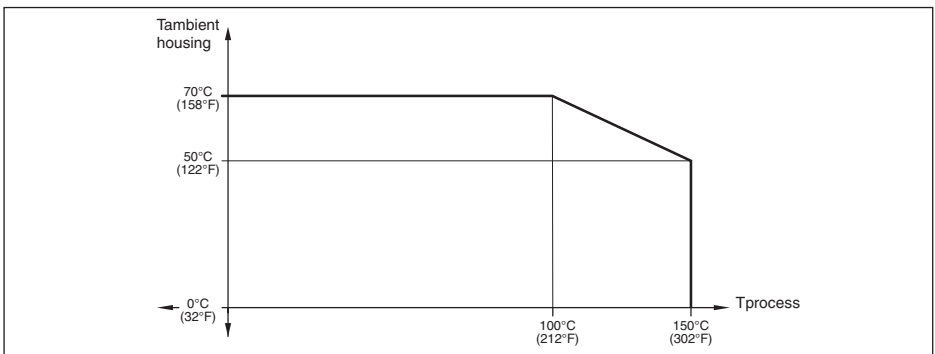

VEGABAR 81, VEGABAR 83

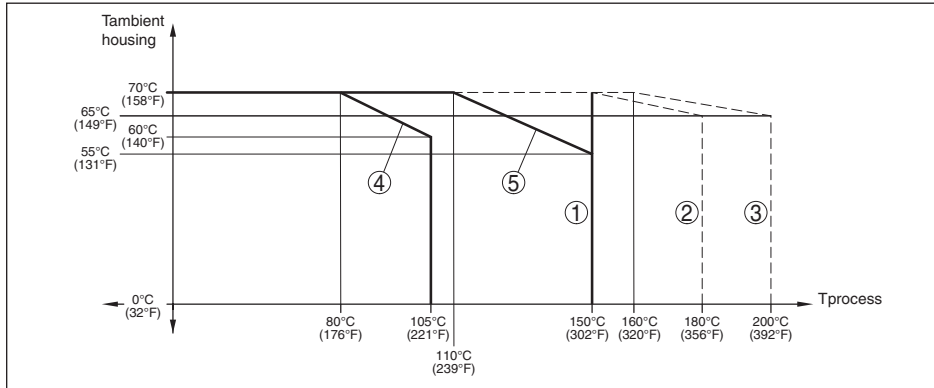

- 1 Version: METEC measuring cell, process temperature max. 150 °C
- 2 Version: METEC measuring cell, process temperature max. 180 °C
- 3 Version: METEC measuring cell, process temperature max. 200 °C
- 4 Version: Piezoresistive/strain gauge measuring cell, without cooling element
- 5 Version: Piezoresistive/strain gauge measuring cell, with cooling element

The temperature ranges for operation specified in the operating instruction must not be exceeded.

5 Protection against static electricity

The VEGABAR B8*.CC/U/O/H/T, VEGABAR B8*.VC in versions with electrostatically chargeable plastic parts, such as e.g. plastic housing, metal housing with inspection window, with plastic coated sensors, suspension cable or suspension hose, distance tube or connection cable with the separated version, a caution label points out the safety measures that must be taken with regard to electrostatic charges during operation.

WARNING -- POTENTIAL ELECTROSTATIC CHARGING HAZARD -- SEE INSTRUCTIONS

AVERTISSEMENT -- DANGER POTENTIEL DE CHARGES ÉLECTROSTATIQUES -- VOIR INSTRUCTIONS

Caution: Plastic parts! Danger of electrostatic charging!

- Avoid friction
- No dry cleaning
- Do not mount in areas with flowing, non-conductive products

6 Use of an overvoltage arrester

If necessary, a suitable overvoltage arrester can be connected in front of the VEGABAR B8*.CC/U/O/H/T, VEGABAR B8*.VC.

When used as Class I, Zone 0, 0/1, instrument, as far as necessary analogue, a suitable overvoltage arrester must be connected in front as protection against voltage surges.

7 Grounding

In order to avoid the danger of electrostatic charging of the metallic parts, the VEGABAR B8*.CC/U/O/H/T, VEGABAR B8*.VC must be electrostatically connected to the local potential equalisa-

tion (transfer resistance $\leq 1 \text{ M}\Omega$), e.g. via the ground terminal.

8 Impact and friction sparks

VEGABAR B8*.CC/U/O/H/T, VEGABAR B8*.VC in aluminium/titanium versions must be mounted in such a way that sparks from impact and friction between aluminium/titanium and steel (except stainless steel, if the presence of rust particles can be excluded) cannot occur.

9 Material resistance

VEGABAR B8*.CC/U/O/H/T, VEGABAR B8*.VC must only be used in products against which the wetted materials are sufficiently resistant.

10 Mounting with external indicating unit VEGADIS 81

The intrinsically safe signal circuit between VEGABAR B8*.CC/U/O/H/T, VEGABAR B8*.VC and the external indicating unit VEGADIS 81 should be set up without grounding. The required insulation voltage is $> 500 \text{ V AC}$. When using the VEGA connection cable included with the delivery, this requirement is fulfilled. If grounding of the cable screen is required, it must be carried out accordingly.

11 Installation/mounting

The VEGABAR B8*.CC/U/O/H/T, VEGABAR B8*.VC have to be mounted such that the sensor is effectively secured against touching the vessel wall, under consideration of other vessel installations and flow conditions in the vessel. This applies especially to suspension pressure transmitters and versions with distance tube lengths over 3 m.

The continuous operating temperature of the connection cable must be suitable for the temperature range of the application.

12 Installation of the VEGABAR B8*.CC/U/O/H/T, VEGABAR B8*.VC with separate housing

With the version with separate housing of the pressure transmitter VEGABAR B8*.CC/U/O/H/T, VEGABAR B8*.VC, the potential equalization must be provided in the complete range of the connection cable between electronics housing and transmitter housing.

13 Installation Diagram

VEGABAR B8*.CC/U/O/H/T, VEGABAR B8*.VC with electronics 4 ... 20 mA/HART

VEGA Display VEGADIS 81, VEGABAR B8*.CC, VC with electronics S, T

Hazardous (Classified) Locations

Unclassified Locations

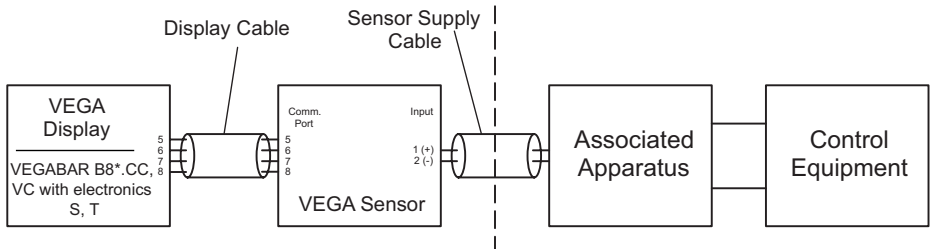

Fig. 1: VEGABAR B8*.CC/U/O/H/T, VEGABAR B8*.VC (Electronics 4 ... 20 mA/HART) - Single chamber housing

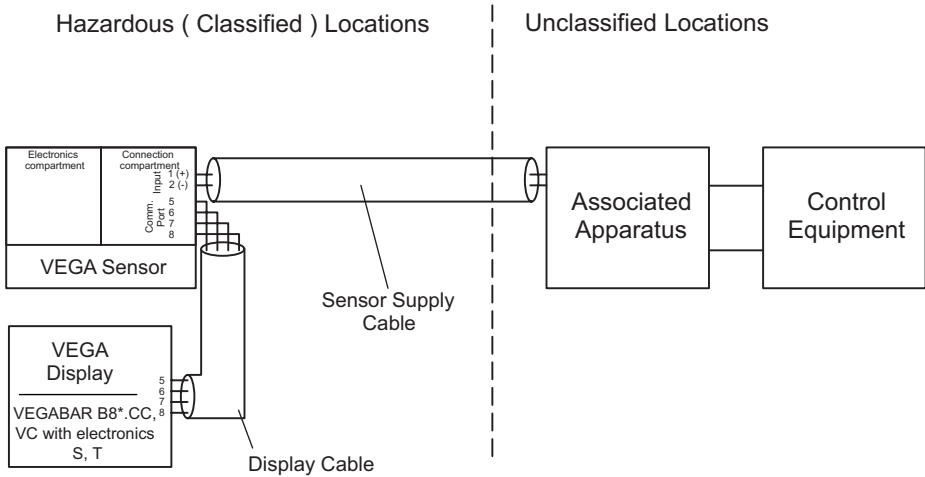

Fig. 2: VEGABAR B8*.CC/U/O/H/T, VEGABAR B8*.VC (Electronics 4 ... 20 mA/HART) - Double chamber housing

General

The Intrinsic Safety Entity concept allows the interconnection of two intrinsically safe devices with entity parameters not specifically examined in combination as a system when:

$$U_o \text{ or } V_{oc} \text{ or } V_t \leq V_{max}$$

$$I_o \text{ or } I_{sc} \text{ or } I_t \leq I_{max}$$

$$P_o \leq P_i$$

$$C_a \text{ or } C_o \geq C_{cable}$$

$$L_a \text{ or } L_o \geq L_{cable}$$

For Division 2 installations, the Associated Apparatus is required to be Certified under Entity Concept if the VEGABAR Series is installed in accordance with the National Electrical Code ® (ANSI/NFPA 70) od Canadian Electrical Code, CSA C22.1 Part 1 Appendix F, for division 2 wiring methods excluding Nonincendive field wiring.

Division 1 installations should be in accordance with ANSI/ISA RP12.06.01 "Installation of Intrinsically Safe Systems for Hazardous (Classified) Locations" and the National Electrical Code ® (ANSI/ NRPA 70) od Canadian Electrical Code.

The configuration of Field Device must be Certified under Entity Concept.
 The Field Device manufacturer's installation drawing shall be followed when installing this equipment.

The VEGABAR Series are Certified for Class I, Zone 0, application. If connecting [Ex ib] / [AEx ib] Associated Apparatus or Ex ib / AEx ib I.S. Field Device to the VEGABAR series 80, the above system is only suitable for Class I, Zone 1, and is not suitable for Class I, Zone 0 Hazardous (Classified) Locations.

WARNING: Substitution of components may impair suitability for hazardous locations.
 Barriers and instruments to carry same Agency Approval.

Control Equipment

Control equipment connected to the Associated Apparatus shall not use or generate more than 253 Vrms or Vdc.

Associated Apparatus

For Division 1 installations, the configuration of associated Apparatus shall be CSA Certified under Entity Concept.

Associated Apparatus manufacturer's installation drawing shall be followed when installing this equipment.

VEGA Sensor

The VEGA Sensor is a VEGABAR B8*.CC/U/O/H/T, VEGABAR B8*.VC.

VEGABAR B8*(*).FC/O (Electronics 4 ... 20 mA/HART)

$$U_i = 30 \text{ V}$$

$$I_i = 131 \text{ mA}$$

$$P_i = 983 \text{ mW}$$

The effective internal capacitance is C_i is negligibly small.

The effective internal inductance is $L_i \leq 5 \mu\text{H}$.

In the double chamber version is the effective internal inductance $L_i \leq 10 \mu\text{H}$.

For the version with fixed cable:

$$L_i' = 0,62 \mu\text{H/m}$$

$$C_i'_{\text{wire/wire}} = 150 \text{ pF/m}$$

$$C_i''_{\text{wire/screen}} = 270 \text{ pF/m}$$

These values must be taken into the account.

Sensor Supply Cable

Interconnection VEGABAR B8*(*).FC/O with implemented electronics H, A (0 ... 20 mA/HART) with: Display VEGADIS 81; VEGABAR B8*(*).FC/O with implemented electronics S, T
The configuration of Field Device must be CSA Certified under Entity Concept.

The Field Device manufacturer's installation drawing shall be followed when installing this equipment.

Cable between VEGABAR B8*(*).FC/O with implemented electronics H, A (0 ... 20 mA/HART) and: Display VEGADIS 81; VEGABAR B8*(*).FC/O with implemented electronics S, T

The regulations for the interconnection of intrinsically safe circuits between VEGABAR B8*.CC/U/O/H/T, VEGABAR B8*.VC and the external indication and adjustment unit are complied with if the total inductance and total capacity of the connection cable between VEGABAR B8*.CC/U/O/H/T, VEGABAR B8*.VC or VEGABAR B8*(*).FC/O with implemented electronics S, T and the external indication and adjustment unit $L_{\text{cable}} = 300 \mu\text{H}$ and $C_{\text{cable}} = 1.98 \mu\text{F}$ are not exceeded. The indication and adjustment module integrated in VEGABAR B8*.CC/U/O/H/T, VEGABAR B8*.VC with implemented electronics A, H or VEGABAR B8*(*).FC/O with implemented electronics S, T and the connected interface converter are taken into account.

In case of using the connection cable delivered from VEGA between the VEGABAR B8*.CC/U/O/H/T, VEGABAR B8*.VC and the display VEGADIS 81 or VEGABAR B8*(*).FC/O with implemented electronics S, T the following parameters has to be considered:

$$L_i' = 0.62 \mu\text{H/m}$$

$$C_i'_{\text{wire/wire}} = 150 \text{ pF/m}$$

$$C_i''_{\text{wire/screen}} = 270 \text{ pF/m}$$

VEGABAR B8*.CC/U/O/H/T, VEGABAR B8*.VC with electronics Profibus PA, Foundation Fieldbus

VEGA Display VEGADIS 81, VEGABAR B8*.CC, VC with electronics S, T

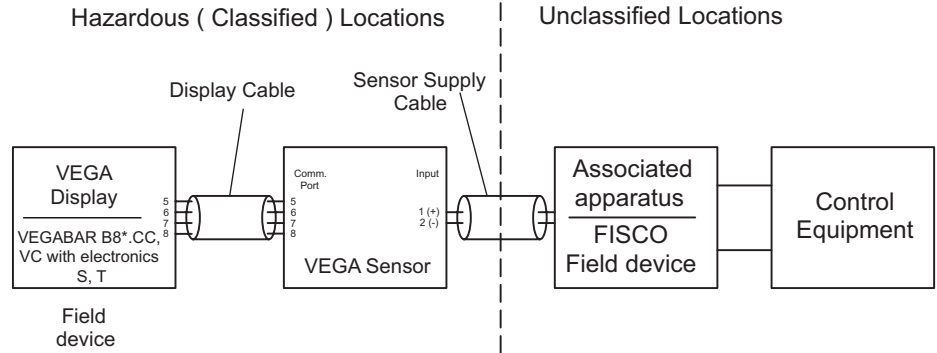

Fig. 3: VEGABAR B8*.CC/U/O/H/T, VEGABAR B8*.VC with electronics Profibus PA, Foundation Fieldbus - Single chamber housing

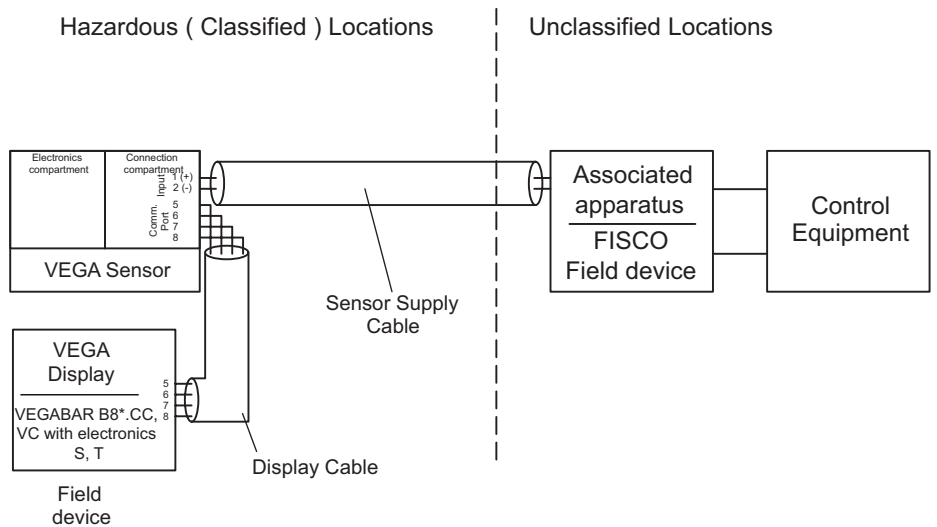

Fig. 4: VEGABAR B8*.CC/U/O/H/T, VEGABAR B8*.VC with electronics Profibus PA, Foundation Fieldbus - Double chamber housing

General

The Intrinsic Safety Entity concept allows the interconnection of two intrinsically safe devices FM Approved and CSA Certified when installed in Canada with entity parameters not specifically examined in combination as a system when:

$$U_o \text{ or } V_{oc} \text{ or } V_i \leq V_{max}$$

$$I_o \text{ or } I_{sc} \text{ or } I_i \leq I_{max}$$

$$P_o \leq P_i$$

$$C_a \text{ or } C_o \geq C_{cable}$$

$$L_a \text{ or } L_o \geq L_{\text{cable}}$$

For Division 2 installations, the Associated Apparatus is required to be FM approved or CSA Certified when installed in Canada under Entity Concept if the VEGABAR B80 Series is installed in accordance with the National Electrical Code ® (ANSI/NFPA 70) or Canadian Electrical Code, CSA C22.1 Part 1 Appendix F, for division 2 wiring methods excluding Nonincendive field wiring.

Division 1 installations should be in accordance with ANSI/ISA RP12.06.01 "Installation of Intrinsically Safe Systems for Hazardous (Classified) Locations" and the National Electrical Code ® (ANSI/NRPA 70) or Canadian Electrical Code.

The configuration of Field Device must be FM Approved / CSA Certified under Entity Concept.

The Field Device manufacturer's installation drawing shall be followed when installing this equipment.

The VEGABAR B80 Series are FM Approved / CSA Certified for Class I, Zone 0, application. If connecting [Ex ib] / [AEx ib] Associated Apparatus or Ex ib / AEx ib I.S. Field Device to the VEGABAR B80 Series, the above system is only suitable for Class I, Zone 1, and is not suitable for Class I, Zone 0 Hazardous (Classified) Locations.

WARNING: Substitution of components may impair suitability for hazardous locations.

Barriers and instruments to carry same Agency Approval.

Control Equipment

Control equipment connected to the Associated Apparatus shall not use or generate more than 253 Vrms or Vdc.

Associated Apparatus

For Division 1 installations, the configuration of associated Apparatus shall be FM approved / CSA Certified under Entity Concept.

Associated Apparatus manufacturer's installation drawing shall be followed when installing this equipment.

The VEGABAR B80 Series are FM Approved / CSA Certified for Class I, Zone 0, application. If connecting [Ex ib] / [AEx ib] Associated Apparatus or Ex ib / AEx ib I.S. Field Device to the VEGABAR B80 Series, the above system is only suitable for Class I, Zone 1, and is not suitable for Class I, Zone 0 Hazardous (Classified) Locations.

VEGABAR B8*.CC/U/O/H/T, VEGABAR B8*.VC with electronics Profibus PA, Foundation Fieldbus

Maximum values:

- $U_i = 17.5 \text{ V}$
- $I_i = 500 \text{ mA}$
- $P_i = 5.5 \text{ W}$

The instrument is suitable for connection to a Fieldbus system according to the FISCO model (IEC 60079-11), e. g. Profibus PA.

or

- $U_i = 24 \text{ V}$
- $I_i = 250 \text{ mA}$
- $P_i = 1.2 \text{ W}$

The effective internal capacitance C_i is negligibly small.

The effective internal inductance is L_i is negligibly small.

In the double chamber version is the effective internal inductance $L_i \leq 5 \mu\text{H}$.

In the version with fix-mounted connection cable, the following cable inductances L_i' and cable

capacitances C_i have to be taken into account.

- $L_i' = 0.62 \mu\text{H/m}$
- $C_{i, \text{wire/wire}}' = 150 \text{ pF/m}$
- $C_{i, \text{wire/screen}}' = 270 \text{ pF/m}$

Interconnection VEGABAR B8*(*).FC/O with implemented electronics P (Profibus PA), F (Foundation Fieldbus) with: Display VEGADIS 81; VEGABAR B8*(*).FC/O with implemented electronics S, T

The configuration of Field Device must be FM Approved / CSA Certified under Entity Concept.

The Field Device manufacturer's installation drawing shall be followed when installing this equipment.

The VEGABAR B80 Series are FM Approved / CSA Certified for Class I, Zone 0, application. If connecting [Ex ib] / [AEx ib] Associated Apparatus or Ex ib / AEx ib I.S. Field Device to the VEGABAR B80 Series, the above system is only suitable for Class I, Zone 1, and is not suitable for Class I, Zone 0 Hazardous (Classified) Locations.

Cable between VEGABAR B8*(*).FC/O with implemented electronics P (Profibus PA), F (Foundation Fieldbus) and: Display VEGADIS 81; VEGABAR B8*(*).FC/O with implemented electronics S, T

The regulations for the interconnection of intrinsically safe circuits between VEGABAR B8*.CC/U/O/H/T, VEGABAR B8*.VC and the external indication and adjustment unit are complied with if the total inductance and total capacity of the connection cable between VEGABAR B8*.CC/U/O/H/T, VEGABAR B8*.VC or VEGABAR B8*(*).FC/O with implemented electronics S, T and the external indication and adjustment unit $L_{\text{cable}} = 212 \mu\text{H}$ and $C_{\text{cable}} = 1.98 \mu\text{F}$ are not exceeded. The indication and adjustment module integrated in VEGABAR B8*.CC/U/O/H/T, VEGABAR B8*.VC with implemented electronics A, H or VEGABAR B8*(*).FC/O with implemented electronics S, T and the connected interface converter are taken into account.

In case of using the connection cable delivered from VEGA between the VEGABAR B8*.CC/U/O/H/T, VEGABAR B8*.VC and the display VEGADIS 81 or VEGABAR B8*(*).FC/O with implemented electronics S, T the following parameters has to be considered:

- $L_i' = 0.62 \mu\text{H/m}$
- $C_{i, \text{wire/wire}}' = 150 \text{ pF/m}$
- $C_{i, \text{wire/screen}}' = 270 \text{ pF/m}$

VEGABAR Version with external housing

The cable between the external housing with implemented electronics and the process unit is an intrinsic safe circuit.

The regulations for the interconnection of intrinsically safe circuits between VEGABAR B8* housing and the process unit are complied with the length of the cable between external housing and the process unit does not exceed 180 meter.

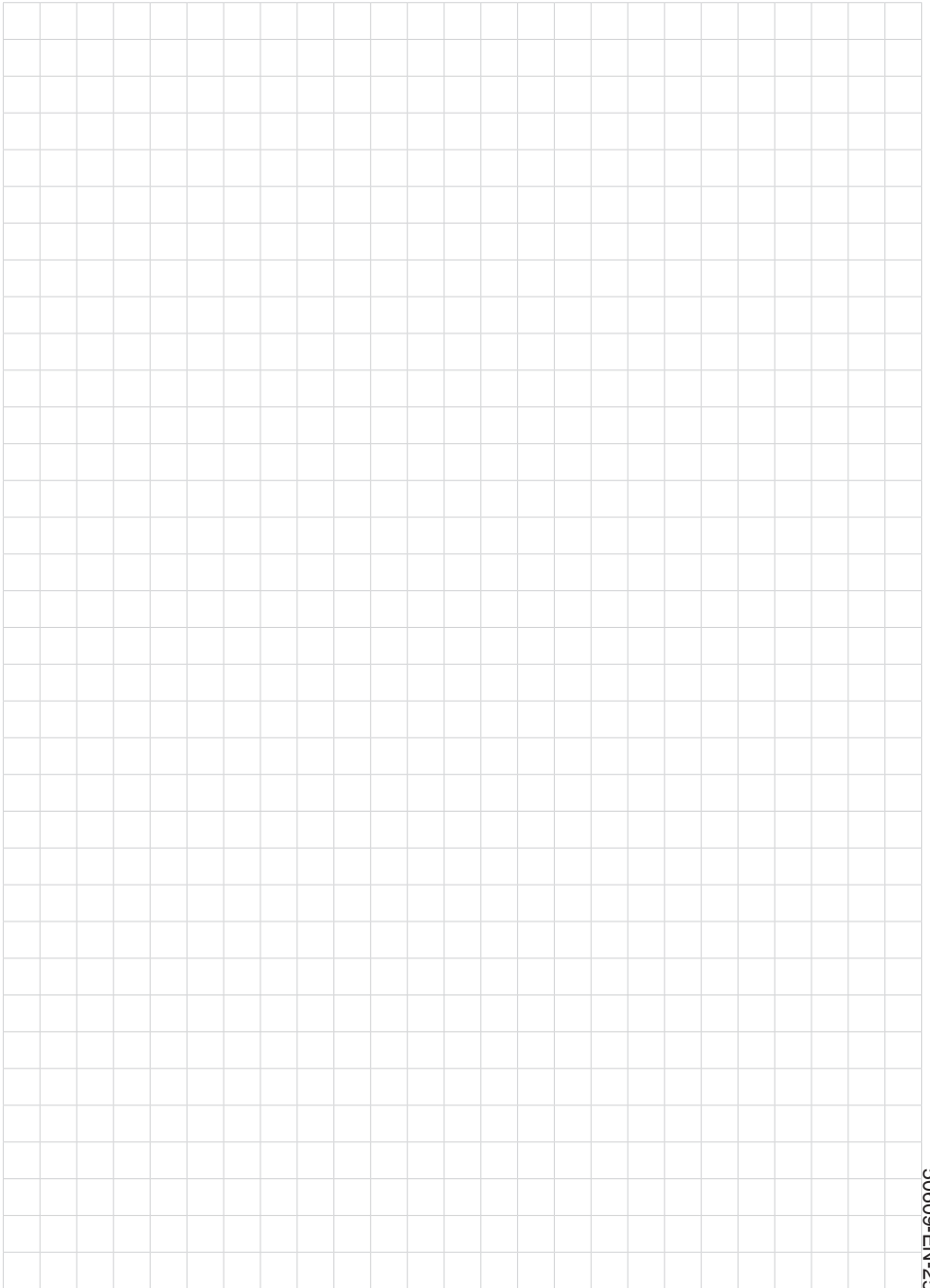

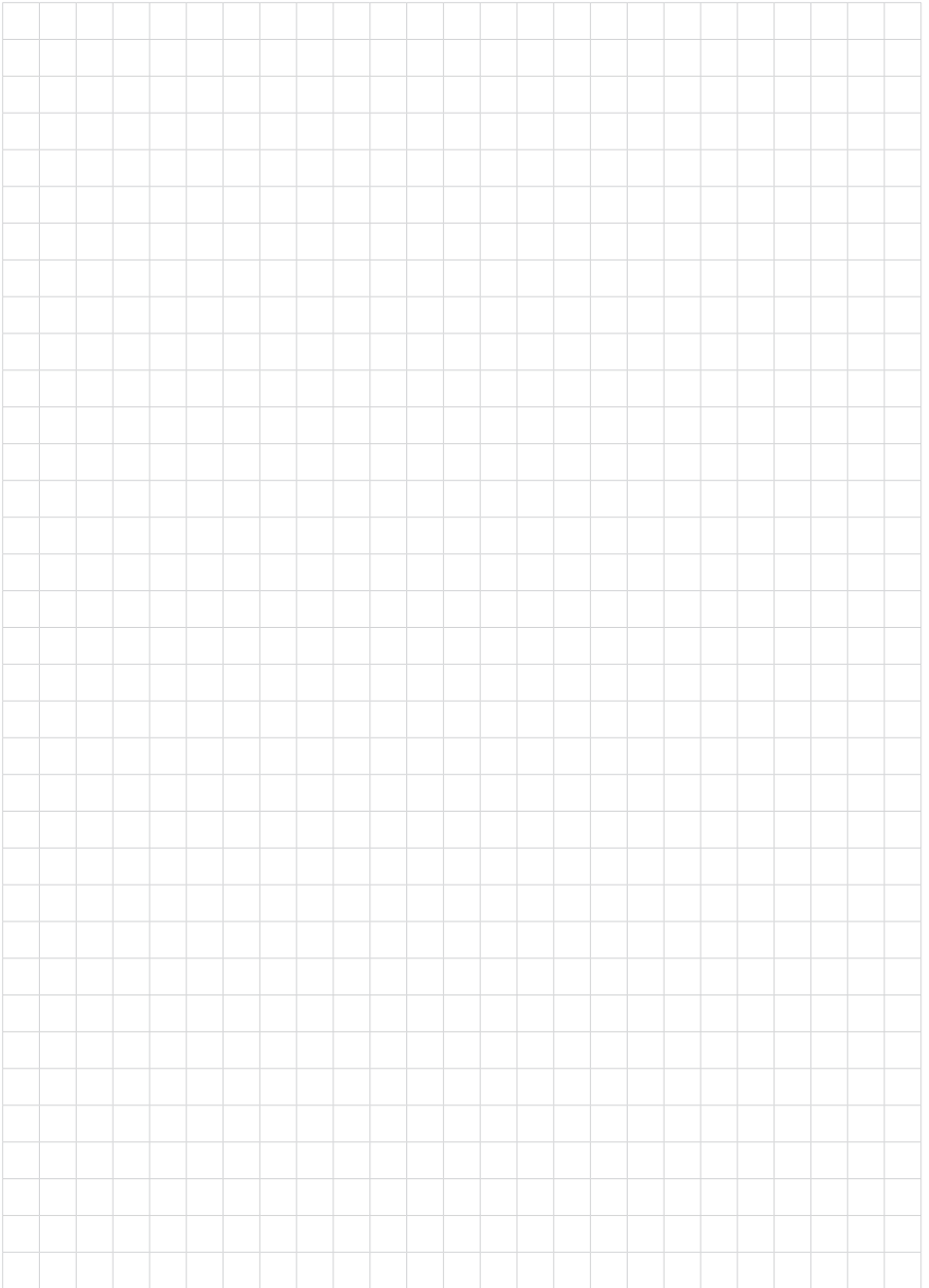

Printing date:

VEGA

All statements concerning scope of delivery, application, practical use and operating conditions of the sensors and processing systems correspond to the information available at the time of printing.

Subject to change without prior notice

© VEGA Grieshaber KG, Schiltach/Germany 2025

50609-EN-251118

VEGA Grieshaber KG
Am Hohenstein 113
77761 Schiltach
Germany

Phone +49 7836 50-0
E-mail: info.de@vega.com
www.vega.com