



Safety instructions

VEGABAR B8*(*).CD/V/P/I

VEGABAR B8*(*).VD

CSA 70015745

CL I, Div 1, GR A, B, C, D

Ex d ia IIC T6 ... T1 Gb

CL I, Zone 0/1, 1, AEx d ia Gb



Document ID: 50613



VEGA

Contents

1	Area of applicability	3
2	General information	3
3	Technical data	3
4	Application conditions	5
5	Protection against static electricity	8
6	Use of an overvoltage arrester	8
7	Grounding.....	8
8	Impact and friction sparks	9
9	Material resistance	9
10	Mounting with external indicating unit VEGADIS 81	9
11	Installation/mounting	9
12	Installation of the VEGABAR B8*(*).CD/V/P/I, VEGABAR B8*(*).VD with separate housing 9	
13	Ignition protection type flameproof enclosure Ex "d"	9
14	Type and size of the threads for the "Ex-d" cable entries	10
15	Removing and replacing the red thread/dust cover.....	10
16	Installation Diagram	11

Supplementary documentation:

- Operating Instructions VEGABAR 81, 82, 83, 86, 87
- Certificate of Conformity CSA 70015745 (Document ID: 50601)

Editing status: 2025-11-18

1 Area of applicability

These safety instructions apply to the pressure transmitters VEGABAR B81/82/83/86/87.CD/V/P/I and VEGABAR B81/82/83/86/87.VD with integrated electronics Z (4 ... 20 mA), H (4 ... 20 mA/HART), U (Modbus) according to Certificate of Conformity CSA 70015745 (certificate number on the type label) and for all instruments with the number of the safety instruction (50613) on the type label.

2 General information

The pressure-based measuring instruments VEGABAR B8*(*).CD/V/P/I, VEGABAR B8*(*).VD are also used for pressure and level measurement in hazardous areas.

The measured products can also be combustible liquids, gases, mist or vapour.

The VEGABAR B8*(*).CD/V/P/I, VEGABAR B8*(*).VD consist of an electronics housing with an "Ex-d" connection compartment with barrier and an "Ex-i" connection compartment with integrated electronics module, a process connection element and a sensor, the pressure measuring cell with optional isolating diaphragm. The indicating and adjustment module can also be integrated in the "Ex-i" connection compartment.

The VEGABAR B8*(*).CD/V/P/I, VEGABAR B8*(*).VD are suitable for use in hazardous atmospheres of all combustible materials of explosion groups A, B, C, D for applications requiring Class I, Div 1 instruments or for explosions groups IIA, IIB, IIC for applications requiring Class I, Zone 0/1, 1, AEx d ia IIC, T6 Gb or Ex d ia IIC T6 ... T1 Gb instruments.

If the VEGABAR B8*(*).CD/V/P/I, VEGABAR B8*(*).VD are installed and operated in hazardous areas, the general Ex installation regulations in the Canadian Electrical Code, US national Electrical Code, IEC 60079-14 as well as these safety instructions must be observed.

The operating instructions as well as the installation regulations or standards that apply for explosion protection of electrical systems must generally be observed.

The installation of explosion-endangered systems must always be carried out by qualified personnel.

Installation at the separation between Zone 0 and Zone 1

The process connection element is installed in the separating wall, which separates areas in which EPL-Ga or EPL-Gb instruments are required. The electronics housing is installed in hazardous areas, requiring EPL-Gb instruments. The sensor is installed in hazardous areas requiring EPL-Ga instruments.

Zone 1 installation

The VEGABAR B8*(*).CD/V/P/I, VEGABAR B8*(*).VD are installed in hazardous areas requiring EPL-Gb instruments.

Hazardous locations designation

CL I, Div 1, GR A, B, C, D

Ex d ia IIC T6 ... T1 Gb

CL I, Zone 0/1, 1 AEx d ia IIC T6 ... T1 Gb

3 Technical data

Non-intrinsically safe circuits

VEGABAR B8*(*).CD/V/P/I, VEGABAR B8*(*).VD with integrated electronics Z (4 ... 20 mA), H (4 ... 20 mA/HART)

Supply and signal circuit: (terminals
K11/1, K11/2)

- U = 15 ... 35 V AC
- U_m = 253 V AC/DC

VEGABAR B8*(*)CD/V/P/I, VEGABAR B8*(*)VD with integrated electronics U (Modbus)

Supply circuit: (terminals K11[+], K12[-])	<ul style="list-style-type: none"> ● $U = 8 \dots 32 \text{ V DC}$ ● $U_m = 253 \text{ V AC/DC}$
Signal circuit: (terminals MB[+], MB[-])	<ul style="list-style-type: none"> ● $U_{\max} = 5 \text{ V}$ with MODBUS signal (telegram) ● $U_m = 253 \text{ V AC/DC}$
USB connection: (6-pole mini USB socket)	<ul style="list-style-type: none"> ● $U_{\max} = 5 \text{ V}$ ● USB signal (USB protocol) ● $U_m = 253 \text{ V AC/DC}$

Intrinsically safe circuits

VEGABAR B8*(*)CD/V/P/I, VEGABAR B8*(*)VD with integrated electronics Z (4 ... 20 mA), H (4 ... 20 mA/HART) or U (Modbus)

Display and adjustment circuit: Terminals 5, 6, 7, 8 in the electronics compartment or plug connection in Housing version/Protection P (with M12 x 1 for VEGADIS), with electronics U only plug connection	<p>In ignition protection type intrinsic safety Ex ia IIC</p> <p>For connection to the intrinsically safe circuit of the corresponding external display unit VEGADIS 81 or for connection of a VEGABAR B80 with integrated electronics S or T intrinsically safe differential pressure measurement.</p> <p>The rules for the interconnection of intrinsically safe circuits between VEGABAR B8*(*)CD/V/P/I, VEGABAR B8*(*)VD and the external indicating unit VEGADIS 81 or VEGABAR B8* with electronics S or T are fulfilled, provided that the total inductance and total capacitance of the connection cable between VEGABAR B8*(*)CD/V/P/I, VEGABAR B8*(*)VD and the external indicating unit VEGADIS 81 or VEGABAR B8* with electronics S or T $L_{\text{cable}} = 330 \mu\text{H}$ and $C_{\text{cable}} = 2 \mu\text{F}$ are not exceeded.</p> <p>When using the delivered VEGA connection cable between VEGABAR B8*(*)CD/V/P/I, VEGABAR B8*(*)VD and the external indicating unit VEGADIS 81 or VEGABAR B8* with electronics S or T, the following listed cable inductances L_i and cable capacitances C_i must be taken into account with a cable length $\geq 50 \text{ m}$.</p> <ul style="list-style-type: none"> ● $L_i = 0.62 \mu\text{H/m}$ ● $C_{i \text{ wire/wire}} = 150 \text{ pF/m}$ ● $C_{i \text{ wire/screen}} = 270 \text{ pF/m}$
------------------------------------------------------------------------------------------------------------------------------------------------------------------------------------------------------------	-----------------------------------------------------------------------------------------------------------------------------------------------------------------------------------------------------------------------------------------------------------------------------------------------------------------------------------------------------------------------------------------------------------------------------------------------------------------------------------------------------------------------------------------------------------------------------------------------------------------------------------------------------------------------------------------------------------------------------------------------------------------------------------------------------------------------------------------------------------------------------------------------------------------------------------------------------------------------------------------------------------------------------------------------------------------------------------------------------------------------------------------------------------------------------------------------------------------------------------------------------------------------------------------------------------------------------------------------------------------------------------------------------------------------------------------------------------------------------------------

Intrinsically safe circuit for the display and adjustment module

VEGABAR B8*(*)CD/V/P/I, VEGABAR B8*(*)VD with integrated electronics Z (4 ... 20 mA), H (4 ... 20 mA/HART) or U (Modbus)

Circuit for the display and adjustment module: (spring contacts in the "Ex-i" electronics compartment)	<p>In ignition protection type intrinsic safety Ex ia IIC</p> <p>For connection to the display and adjustment module PLICSCOM or VEGACONNECT.</p>
--------------------------------------------------------------------------------------------------------	---------------------------------------------------------------------------------------------------------------------------------------------------

VEGABAR B8*(*)CD/V/P/I, VEGABAR B8*(*)VD Version with separate cable outlet

Circuit between sensor unit and external electronics (terminal 1 - yellow, terminal 2 - white, terminal 3 - red, terminal 4 - black)

In ignition protection type intrinsic safety Ex ia IIC
With VEGABAR B8*.ID in the version with fix mounted cable on the sensor unit and external electronics, the supplied cable between the external housing and the sensor unit must not exceed a length of 180 m.

The intrinsically safe circuits of the VEGABAR B8*(*)CD/V/P/I, VEGABAR B8*(*)VD with electronics Z or H are reliably galvanically separated from the non-intrinsically safe circuit up to a peak value of 375 V.

The intrinsically safe circuits of VEGABAR B8*(*)CD/V/P/I, VEGABAR B8*(*)VD with electronics U are galvanically connected with the non-intrinsically safe circuits via the internal and external ground connection terminal with ground potential.

All versions: The intrinsically safe circuits to the sensor are galvanically connected to ground potential.

4 Application conditions

VEGABAR B8*(*)CD/V/P/I, VEGABAR B8*(*)VD with integrated electronics Z (4 ... 20 mA), H (4 ... 20 mA/HART) or U (Modbus)

The max. permissible ambient temperatures depending on the temperature classes are specified in the following tables.

Installation at the separation between Zone 0 and Zone 1, Division 1 installations

Temperature class	Ambient temperature (electronics, zone 1)		Product temperature range (measuring sensor, zone 0)
	VEGABAR B8* with electronics Z, H	VEGABAR B8* with electronics U	
T6	-50 ... +46 °C	-40 ... +46 °C	-20 ... +23 °C
T5, T4, T3, T2, T1	-50 ... +60 °C	-40 ... +60 °C	-20 ... +60 °C

Installation at the separation between Zone 0 and Zone 1, Division 1 installation the process pressure of the media must be between 0.8 ... 1.1 bar. The 80% consideration of Sect. 6.4.2/EN 1127-1 is taken into account with the permissible ambient temperatures. If the VEGABAR B8*(*)CD/V/P/I, VEGABAR B8*(*)VD are operated at temperatures higher than those specified in the above table, please make sure by means of appropriate measures that there is no danger of ignition from the hot surfaces. The maximum temperature on the electronics/housing should not exceed the values stated in the above table. The application conditions in areas without hazardous mixtures are specified in the manufacturer information.

Div 1, Zone 1 installation, VEGABAR 82, VEGABAR 83 version with METEC measuring cell

Temperature class	Ambient temperature (electronics, zone 1)		Product temperature range (measuring sensor, zone 1)
	VEGABAR B8* with electronics Z, H	VEGABAR B8* with electronics U	
T6	-50 ... +46 °C	-40 ... +46 °C	-50 ... +39 °C
T5	-50 ... +60 °C	-40 ... +60 °C	-50 ... +100 °C

Temperature class	Ambient temperature (electronics, zone 1)		Product temperature range (measuring sensor, zone 1)
	VEGABAR B8* with electronics Z, H	VEGABAR B8* with electronics U	
T4	-50 ... +50 °C	-40 ... +50 °C	-50 ... +135 °C
T3, T2, T1	-50 ... +50 °C	-40 ... +50 °C	-50 ... +200 °C

Div 1, Zone 1 installation, VEGABAR 83 version with piezoresistive/strain gauge measuring cell, version without cooling element

Temperature class	Ambient temperature (electronics, zone 1)		Product temperature range (measuring sensor, zone 1)
	VEGABAR B8* with electronics Z, H	VEGABAR B8* with electronics U	
T6	-50 ... +46 °C	-40 ... +46 °C	-50 ... +39 °C
T5	-50 ... +60 °C	-40 ... +60 °C	-50 ... +85 °C
T4	-50 ... +40 °C	-40 ... +40 °C	-50 ... +105 °C
T4, T3, T2, T1	-50 ... +30 °C	-40 ... +30 °C	-50 ... +120 °C

Div 1, Zone 1 installation, VEGABAR 81, VEGABAR 83 version with piezoresistive/strain gauge measuring cell, version with cooling element

Temperature class	Ambient temperature (electronics, zone 1)		Product temperature range (measuring sensor, zone 1)
	VEGABAR B8* with electronics Z, H	VEGABAR B8* with electronics U	
T6	-50 ... +46 °C	-40 ... +46 °C	-50 ... +39 °C
T5	-50 ... +60 °C	-40 ... +60 °C	-50 ... +85 °C
T4	-50 ... +50 °C	-40 ... +50 °C	-50 ... +120 °C
T3, T2, T1	-50 ... +40 °C	-40 ... +40 °C	-50 ... +150 °C

If the VEGABAR B8*(*)..CD/V/P/I, VEGABAR B8*(*)..VD are operated at temperatures higher than those specified in the above table, please make sure through appropriate measures that there is no danger of ignition from the hot surfaces. The max. permissible temperature on the electronics/housing should not exceed the values specified in the above table. The application conditions during operation with no explosive mixtures present are stated in the manufacturer information.

Temperature derating

VEGABAR 82, version process temperature +130 °C

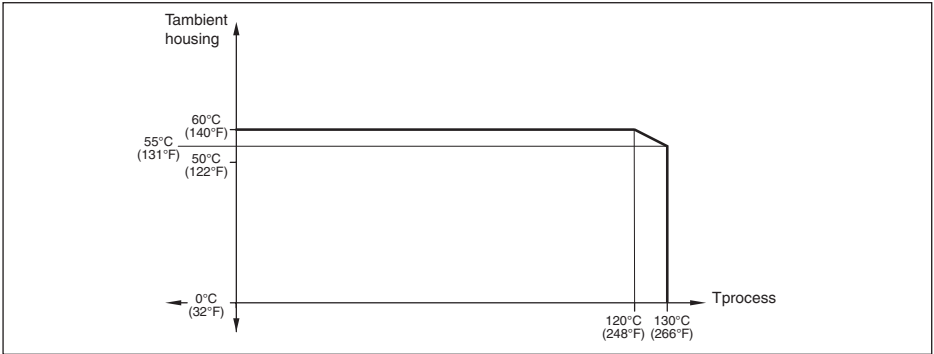

VEGABAR 82, version process temperature +150 °C

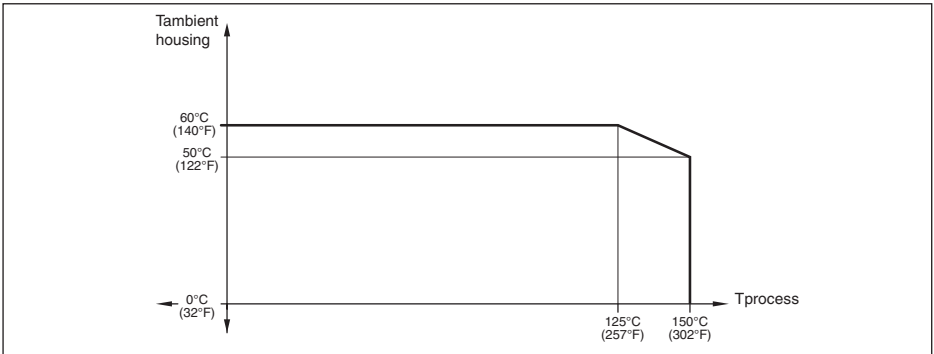

VEGABAR 83

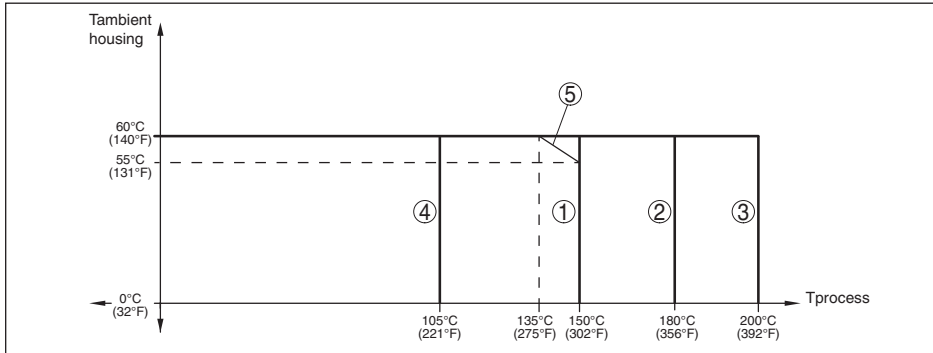

- 1 Version: METEC measuring cell, process temperature max. 150 °C
- 2 Version: METEC measuring cell, process temperature max. 180 °C
- 3 Version: METEC measuring cell, process temperature max. 200 °C
- 4 Version: Piezoresistive/strain gauge measuring cell, without cooling element
- 5 Version: Piezoresistive/strain gauge measuring cell, with cooling element

The temperature ranges for operation specified in the operating instruction must not be exceeded.

5 Protection against static electricity

The VEGABAR B8*(*)..CD/V/P/I, VEGABAR B8*(*)..VD in the version with chargeable plastic parts, like e.g. metal housing with inspection window or plastic-coated measuring sensor are provided with a caution label referring to the safety measures that must be taken in case of electrostatic charging during operation.

WARNING -- POTENTIAL ELECTROSTATIC CHARGING
HAZARD -- SEE INSTRUCTIONS

AVERTISSEMENT -- DANGER POTENTIEL DE CHARGES
ÉLECTROSTATIQUES -- VOIR INSTRUCTIONS

Caution: Plastic parts! Danger of electrostatic charging!

- Avoid friction
- No dry cleaning
- Do not mount in areas with flowing, non-conductive products

6 Use of an overvoltage arrester

If necessary, a suitable overvoltage arrester can be connected in front of the VEGABAR B8*(*)..CD/V/P/I, VEGABAR B8*(*)..VD.

A suitable overvoltage arrester must be connected in front as protection against voltage surges according to IEC 60079-14 chapter 12.3.

7 Grounding

The "Ex-d" connection compartment of VEGABAR B8*(*)..CD/V/P/I, VEGABAR B8*(*)..VD with electronics U (Modbus) contains a safety barrier without electrical isolation. The intrinsically safe circuits must be grounded due to safety reasons. The external and internal earth terminal on the housing of VEGABAR B8*(*)..CD/V/P/I, VEGABAR B8*(*)..VD is used for this purpose.

In order to avoid the danger of electrostatic charging of the metallic parts, the VEGABAR B8*(*) .CD/V/P/I, VEGABAR B8*(*) .VD, must be electrostatically connected to the local potential equalisation (transfer resistance $\leq 1 \text{ M}\Omega$), e.g. via the ground terminal.

8 Impact and friction sparks

VEGABAR B8*(*) .CD/V/P/I, VEGABAR B8*(*) .VD in aluminium/titanium versions must be mounted in such a way that sparks from impact and friction between aluminium/titanium and steel (except stainless steel, if the presence of rust particles can be excluded) cannot occur.

9 Material resistance

VEGABAR B8*(*) .CD/V/P/I, VEGABAR B8*(*) .VD should only be used in media against which the wetted materials are sufficiently resistant.

10 Mounting with external indicating unit VEGADIS 81

The intrinsically safe signal circuit between VEGABAR B8*(*) .CD/V/P/I, VEGABAR B8*(*) .VD and the external indicating unit VEGADIS 81 should be set up without grounding. The required insulation voltage is $> 500 \text{ V AC}$. When using the VEGA connection cable included with the delivery, this requirement is fulfilled. If grounding of the cable screen is required, it must be carried out according to IEC 60079-14 paragr. 12.2.2.3.

11 Installation/mounting

The VEGABAR B8*(*) .CD/V/P/I, VEGABAR B8*(*) .VD have to be mounted such that the sensor is effectively secured against touching the vessel wall, under consideration of other vessel installations and flow conditions in the vessel. This applies especially to suspension pressure transmitters and versions with distance tube lengths over 3 m.

The continuous operating temperature of the connection cable must be suitable for the temperature range of the application.

12 Installation of the VEGABAR B8*(*) .CD/V/P/I, VEGABAR B8*(*) .VD with separate housing

With the version with separate housing of the pressure transmitter VEGABAR B8*(*) .CD/V/P/I, VEGABAR B8*(*) .VD, the potential equalization must be provided in the complete range of the connection cable between electronics housing and transmitter housing.

13 Ignition protection type flameproof enclosure Ex "d"

The terminals for connecting to the operating voltage, i.e. signal circuits, are integrated in a compartment according to protection type explosion proof enclosure "d".

The gaps between housing and cover as well as between threaded fitting and container are ignition-proof gaps.

The explosions proof connection compartment is provided with a M20 x 1.5 or 1/2-14 NPT thread for connection to a certified "Conduit" system or for mounting of a certified explosion proof cable entry (only for zones applications). Cable entries of simple construction may not be used. When connecting to a "Conduit" system, the associated sealing facility must be located directly on the explosions proof connection compartment.

The factory-installed screw plug or blind plug (depending on the type ordered) is part of the "Ex-d" housing. If a non factory-installed screw plug is used, it must be suitable for the function and certified.

Before opening the lid of a "XP/Ex-d" compartment or in case it is already open (e. g. during con-

nection or service work), make sure that either the supply cable is completely voltage free or no explosive atmosphere is present.

When wiring the connection line to the explosion proof connection compartment, it must be sufficiently secured against damage.

The cover of the explosion proof housing must be screwed in completely before commissioning and secured by screwing out the lid locking screw all the way to the stop.

Unused openings must be sealed accordingly.

The cover of the "Ex-d" connection compartment is provided with the warning label "Do not open when an explosive gas atmosphere is present".

Double chamber housing with "Ex-d" connection compartment



- 1 "Ex-i" connection compartment with electronics module
- 2 Locking screw of the cover
- 3 "Ex d" connection compartment with integrated barrier
- 4 Screw plug

14 Type and size of the threads for the "Ex-d" cable entries

The "Ex-d" connection compartment of VEGABAR B8*(*)CD/V/P/I, VEGABAR B8*(*)VD with cable entry type D or 1 has cable entries M20 x 1.5.

The "Ex-d" connection compartment of VEGABAR B8*(*)CD/V/P/I, VEGABAR B8*(*)VD with cable entry type N or Q has cable entries 1/2-14 NPT.

15 Removing and replacing the red thread/dust cover

The red thread or/dust covers screwed in when the instrument is shipped (depending on the version) must be removed before setup. The openings must be closed before setup by a way approved for the flame proofing. Approved and suitable cable glands or blind plugs must be installed according to the supplied documents.

Before setting up VEGABAR B8*(*)CD/V/P/I, VEGABAR B8*(*)VD you have to check if all other openings are closed in a way approved for the ignition protection.

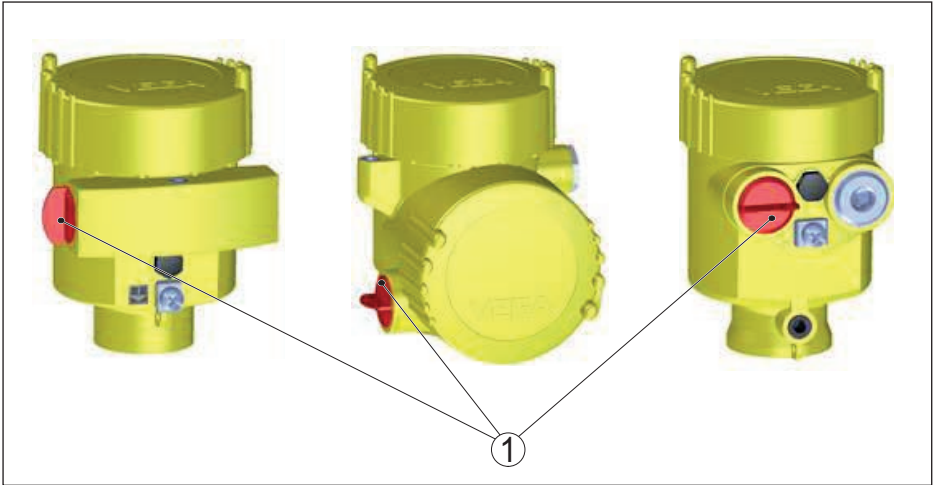

1 Red thread or dust cover must be removed before setup. The opening must be closed before setup by a way approved for the flame proofing.

16 Installation Diagram

Installation Control Diagram

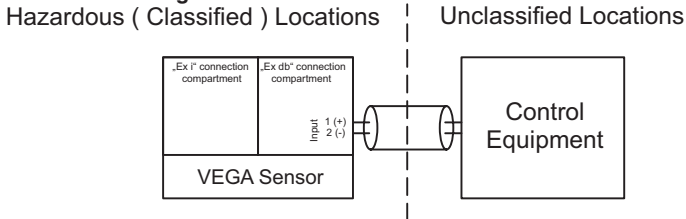

Fig. 1: VEGABAR B8*(*) .CD with electronics 4 ... 20 mA/HART

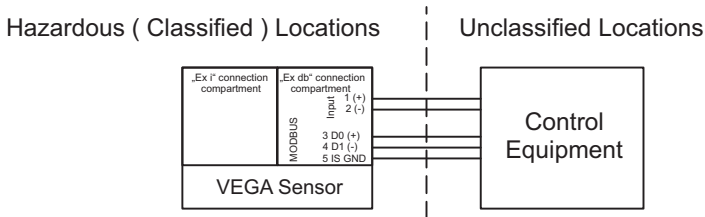

Fig. 2: VEGABAR B8*(*) .CD with electronics MODBUS

General

The Intrinsic Safety Entity concept allows the interconnection of two intrinsically safe devices FM Approved and CSA Certified when installed in Canada with entity parameters not specifically examined in combination as a system when:

$$U_o \text{ or } V_{oc} \text{ or } V_t \leq V_{\max}$$

$$I_o \text{ or } I_{SC} \text{ or } I_l \leq I_{max}$$

$$P_o \leq P_i$$

$$C_a \text{ or } C_o \geq C_{cable}$$

$$L_a \text{ or } L_o \geq L_{cable}$$

Dust-tight conduit seal shall be used when installed in Class II and Class III environments.

For Division 1 Installations the configuration of Field Device must be FM Approved / CSA Certified under Entity Concept.

The Field Device manufacturer's installation drawing shall be followed when installing this equipment.

Division 1 Installation requirements must be complied with if one or more of the following are located in a Division 1 hazardous location: Sensor, Probe or Field Device.

WARNING: Substitution of components may impair suitability for hazardous locations.

WARNING: Do not open when an explosive atmosphere is present.

Barriers and instruments to carry same Agency Approval.

Control Equipment

For Division 1 installations, Control equipment shall not use or generate more than 253 Vrms or Vdc.

Associated Apparatus

For Division 2 installations, the Sensor shall be installed in accordance with the National Electrical Code ® (ANSI/NFPA 70) or Canadian Electrical Code, CSA C22.1 Part 1 Appendix F for Division 2 wiring methods.

For Zone 1 Installations, the terminal marked sign "earth" shall be grounded per ANSI/NFPA 70 article 504.50 or CSA C22.1 Part 1 Appendix F F3.2.2 and the Field Device wiring shall be segregated from the supply wiring.

VEGA Sensor

For Division 2 Installations, the Sensor shall be installed in accordance with the National Electrical Code ® (ANSI/NFPA 70) or Canadian Electrical Code, CSA C22.1 Part 1 Appendix F for Zone 0/1 wiring methods.

The VEGA Sensor is a VEGABAR B8*(*)CD/V/P/I, VEGABAR B8*(*)VD.

For 2 wire: Pins 1 & 2 are for power supply / signal output.

VEGABAR B8*(*)CD with electronics 4 ... 20 mA/HART - Two-wire

Power supply and signal circuit: (terminals 1[+], 2[-] in the explosion proof connection compartment)

$$U = 15 \dots 35 \text{ V AC}$$

$$U_m = 253 \text{ V}$$

VEGABAR B8*(*)CD with electronics MODBUS

Power supply circuit: (terminals 1[+], 2[-] in the explosion proof connection compartment)

$$U = 8 \dots 32 \text{ V DC}$$

$$U_m = 253 \text{ V AC}$$

Signal circuit: (terminals MB[+], MB[-] in the explosion proof connection compartment)

$$U_{max} = 5 \text{ V DC}$$

$$U_m = 253 \text{ V AC/DC}$$

USB connection: (6-pole mini USB socket)

$$U_{max} = 5 \text{ V}$$

USB signal (USB protocol)

Um = 253 V AC/DC

Interconnection VEGABAR B8*(*)CD with implemented electronics H, Z (0 ... 20 mA/HART) U (MODBUS) with: Display VEGADIS 81; VEGABAR B8*(*)CC with implemented electronics S, T

The configuration of Field Device must be FM Approved / CSA Certified under Entity Concept.

The Field Device manufacturer's installation drawing shall be followed when installing this equipment.

For Division 2 Installations, the Sensor shall be installed in accordance with the National Electrical Code ® (ANSI/NFPA 70) or Canadian Electrical Code, CSA C22.1 Part 1 Appendix F for Division 2 wiring methods.

Division 1 installations should be in accordance with ANSI/ISA RP12.06.01 "Installation of Intrinsically Safe Systems for Hazardous (Classified) Locations" and the National Electrical Code ® (ANSI/NFPA 70) or Canadian Electrical Code.

For Division 1 Installations, the terminal marked sign "earth" shall be grounded per ANSI/NFPA 70 article 504.50 or CSA C22.1 Part 1 Appendix F F3.2.2 and the Field Device wiring shall be segregated from the supply wiring.

For Division 2 Installations, the Field Device shall be installed in accordance with the National Electrical Code ® (ANSI/NFPA 70) or Canadian Electrical Code, CSA C22.1 Part 1 Appendix F for Division 2 wiring methods including Nonincendive Field Wiring when using the parameters shown.

Cable between VEGABAR B8*(*)CD with implemented electronics H, Z (0 ... 20 mA/HART) U (MODBUS) with: Display VEGADIS 81; VEGABAR B8*(*)CC with implemented electronics S, T

The regulations for the interconnection of intrinsically safe circuits between VEGABAR B8*(*)CD with electronics 4 ... 20 mA/HART or MODBUS and the external indication and adjustment unit VEGADIS 81 or VEGABAR B8*(*)CC with implemented electronics S, T are complied with if the total inductance and total capacity of the connection cable between VEGABAR B8*(*)CD with electronics 4 ... 20 mA/HART or MODBUS and the external indication and adjustment unit VEGADIS 81 or VEGABAR B8*(*)CC with implemented electronics S, T, $L_{\text{cable}} = 330 \mu\text{H}$ and $C_{\text{cable}} = 2 \mu\text{F}$ are not exceeded.

The indication and adjustment module integrated in VEGABAR B8*(*)CD are taken into account.

In case of using the connection cable delivered from VEGA between the VEGABAR B8*(*)CD with electronics 4 ... 20 mA/HART or MODBUS and external indication or adjustment unit VEGADIS 81 or VEGABAR B8*(*)CC with implemented electronics S, T the following parameters have to be considered:

$$L'_i = 0.62 \mu\text{H/m}$$

$$C'_{i \text{ wire/wire}} = 150 \text{ pF/m}$$

$$C'_{i \text{ wire/screen}} = 270 \text{ pF/m}$$

VEGABAR Version with external housing

The cable between the external housing with implemented electronics and the process unit is an intrinsic safe circuit.

The regulations for the interconnection of intrinsically safe circuits between VEGABAR B8* housing and the process unit are complied with if the length of the cable between external housing and the process unit does not exceed 180 meter.

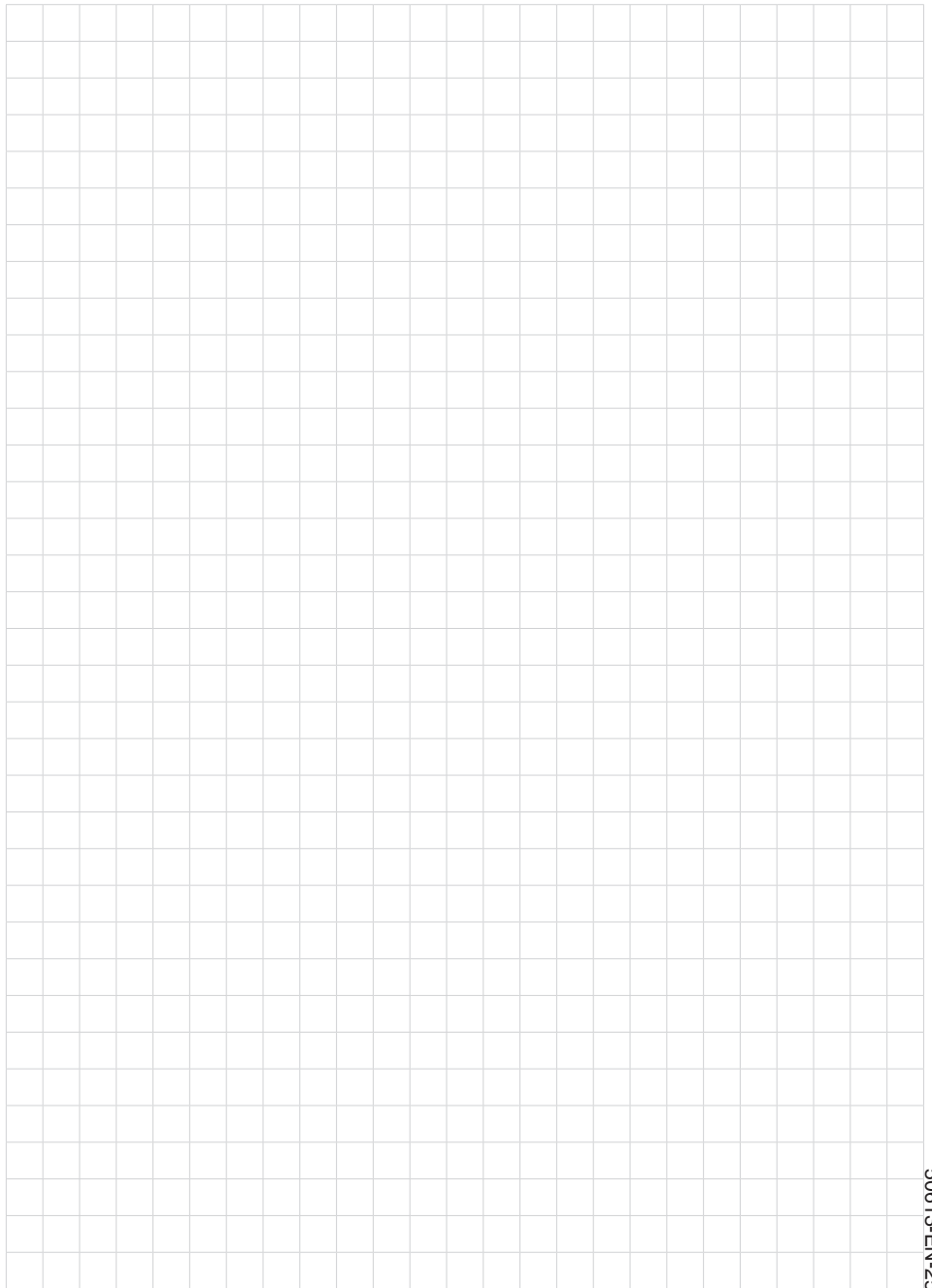

Printing date:

VEGA

All statements concerning scope of delivery, application, practical use and operating conditions of the sensors and processing systems correspond to the information available at the time of printing.

Subject to change without prior notice

© VEGA Grieshaber KG, Schiltach/Germany 2025

50613-EN-251118

VEGA Grieshaber KG
Am Hohenstein 113
77761 Schiltach
Germany

Phone +49 7836 50-0
E-mail: info.de@vega.com
www.vega.com