

# Quick setup guide

Differential pressure transmitter with  
metallic measuring cell

## VEGADIF 85

Foundation Fieldbus



Document ID: 53576



**VEGA**

# Contents

- 1 For your safety ..... 3**
  - 1.1 Authorised personnel ..... 3
  - 1.2 Appropriate use..... 3
  - 1.3 Warning about incorrect use..... 3
  - 1.4 General safety instructions ..... 3
  - 1.5 EU conformity..... 3
  - 1.6 NAMUR recommendations ..... 4
  - 1.7 Environmental instructions ..... 4
- 2 Product description ..... 5**
  - 2.1 Configuration..... 5
- 3 Mounting ..... 6**
  - 3.1 General instructions for use of the instrument ..... 6
- 4 Connecting to power supply..... 8**
  - 4.1 Connecting..... 8
  - 4.2 Single chamber housing..... 9
  - 4.3 Double chamber housing ..... 9
- 5 Set up with the display and adjustment module ..... 10**
  - 5.1 Insert display and adjustment module ..... 10
  - 5.2 Parameter adjustment - Quick setup ..... 11
  - 5.3 Parameter adjustment - Extended adjustment..... 14
  - 5.4 Menu overview ..... 15
- 6 Set up with smartphone/tablet, PC/notebook via Bluetooth..... 17**
  - 6.1 Preparations..... 17
  - 6.2 Connecting..... 18
  - 6.3 Sensor parameter adjustment..... 18
- 7 Supplement ..... 20**
  - 7.1 Technical data ..... 20



**Information:**

This quick setup guide enables quick setup and commissioning of your instrument.

You can find supplementary information in the corresponding, more detailed Operating Instructions Manual as well as the Safety Manual that comes with instruments with SIL qualification. These manuals are available on our homepage.

**Operating instructions VEGADIF 85 - Foundation Fieldbus:  
Document-ID 53570**

Editing status of the quick setup guide: 2020-09-22

## 1 For your safety

### 1.1 Authorised personnel

All operations described in this documentation must be carried out only by trained, qualified personnel authorised by the plant operator.

During work on and with the device, the required personal protective equipment must always be worn.

### 1.2 Appropriate use

VEGADIF 85 is an instrument for measurement of flow, level, differential pressure, density and interface.

You can find detailed information about the area of application in chapter "*Product description*".

Operational reliability is ensured only if the instrument is properly used according to the specifications in the operating instructions manual as well as possible supplementary instructions.

### 1.3 Warning about incorrect use

Inappropriate or incorrect use of this product can give rise to application-specific hazards, e.g. vessel overfill through incorrect mounting or adjustment. Damage to property and persons or environmental contamination can result. Also, the protective characteristics of the instrument can be impaired.

### 1.4 General safety instructions

This is a state-of-the-art instrument complying with all prevailing regulations and directives. The instrument must only be operated in a technically flawless and reliable condition. The operator is responsible for the trouble-free operation of the instrument. When measuring aggressive or corrosive media that can cause a dangerous situation if the instrument malfunctions, the operator has to implement suitable measures to make sure the instrument is functioning properly.

The safety instructions in this operating instructions manual, the national installation standards as well as the valid safety regulations and accident prevention rules must be observed by the user.

For safety and warranty reasons, any invasive work on the device beyond that described in the operating instructions manual may be carried out only by personnel authorised by the manufacturer. Arbitrary conversions or modifications are explicitly forbidden. For safety reasons, only the accessory specified by the manufacturer must be used.

To avoid any danger, the safety approval markings and safety tips on the device must also be observed.

### 1.5 EU conformity

The device fulfils the legal requirements of the applicable EU directives. By affixing the CE marking, we confirm the conformity of the instrument with these directives.

The EU conformity declaration can be found on our homepage.

## 1.6 NAMUR recommendations

NAMUR is the automation technology user association in the process industry in Germany. The published NAMUR recommendations are accepted as the standard in field instrumentation.

The device fulfils the requirements of the following NAMUR recommendations:

- NE 21 – Electromagnetic compatibility of equipment
- NE 43 – Signal level for fault information from measuring transducers
- NE 53 – Compatibility of field devices and display/adjustment components
- NE 107 – Self-monitoring and diagnosis of field devices

For further information see [www.namur.de](http://www.namur.de).

## 1.7 Environmental instructions

Protection of the environment is one of our most important duties. That is why we have introduced an environment management system with the goal of continuously improving company environmental protection. The environment management system is certified according to DIN EN ISO 14001.

Please help us fulfil this obligation by observing the environmental instructions in this manual:

- Chapter "*Packaging, transport and storage*"
- Chapter "*Disposal*"

## 2 Product description

### 2.1 Configuration

#### Type label

The type label contains the most important data for identification and use of the instrument:



Fig. 1: Layout of the type label (example)

- 1 Instrument type
- 2 Product code
- 3 Field for approvals
- 4 Technical data
- 5 Serial number of the instrument
- 6 Data matrix code for VEGA Tools app
- 7 Reminder to observe the instrument documentation

#### Serial number - Instrument search

The type label contains the serial number of the instrument. With it you can find the following instrument data on our homepage:

- Product code (HTML)
- Delivery date (HTML)
- Order-specific instrument features (HTML)
- Operating instructions and quick setup guide at the time of shipment (PDF)
- Order-specific sensor data for an electronics exchange (XML)
- Test certificate (PDF) - optional

Move to "[www.vega.com](http://www.vega.com)" and enter in the search field the serial number of your instrument.

Alternatively, you can access the data via your smartphone:

- Download the VEGA Tools app from the "*Apple App Store*" or the "*Google Play Store*"
- Scan the DataMatrix code on the type label of the instrument or
- Enter the serial number manually in the app

## 3 Mounting

### 3.1 General instructions for use of the instrument

#### Process conditions



**Note:**

For safety reasons, the instrument must only be operated within the permissible process conditions. You can find detailed information on the process conditions in chapter " *Technical data*" of the operating instructions or on the type label.

Hence make sure before mounting that all parts of the instrument exposed to the process are suitable for the existing process conditions.

These are mainly:

- Active measuring component
- Process fitting
- Process seal

Process conditions in particular are:

- Process pressure
- Process temperature
- Chemical properties of the medium
- Abrasion and mechanical influences

#### Protection against moisture

Protect your instrument against moisture ingress through the following measures:

- Use a suitable connection cable (see chapter " *Connecting to power supply*")
- Tighten the cable gland or plug connector
- Lead the connection cable downward in front of the cable entry or plug connector

This applies mainly to outdoor installations, in areas where high humidity is expected (e.g. through cleaning processes) and on cooled or heated vessels.



**Note:**

Make sure that during installation or maintenance no moisture or dirt can get inside the instrument.

To maintain the housing protection, make sure that the housing lid is closed during operation and locked, if necessary.

#### Ventilation

The ventilation for the electronics housing is realised via a filter element in the vicinity of the cable glands.

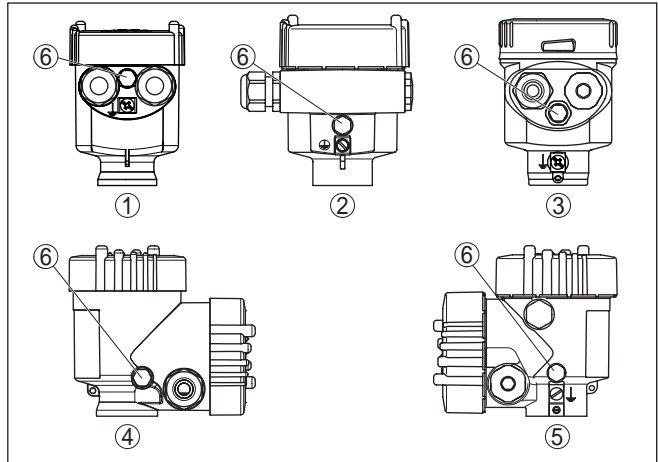

Fig. 2: Position of the filter element - non-Ex, Ex-ia and Ex-d-ia version

- 1 Plastic, stainless steel single chamber (precision casting)
- 2 Aluminium - single chamber
- 3 Stainless steel single chamber (electropolished)
- 4 Plastic double chamber
- 5 Aluminium, stainless steel double chamber housing (precision casting)
- 6 Filter element



**Information:**

Make sure that the filter element is always free of buildup during operation. A high-pressure cleaner may not be used for cleaning.

## 4 Connecting to power supply

### 4.1 Connecting

#### Connection technology

The voltage supply and signal output are connected via the spring-loaded terminals in the housing.

Connection to the display and adjustment module or to the interface adapter is carried out via contact pins in the housing.



#### Information:

The terminal block is pluggable and can be removed from the electronics. To do this, lift the terminal block with a small screwdriver and pull it out. When reinserting the terminal block, you should hear it snap in.

#### Connection procedure

Proceed as follows:

1. Unscrew the housing lid
2. If a display and adjustment module is installed, remove it by turning it slightly to the left
3. Loosen compression nut of the cable gland and remove blind plug
4. Remove approx. 10 cm (4 in) of the cable mantle, strip approx. 1 cm (0.4 in) of insulation from the ends of the individual wires
5. Insert the cable into the sensor through the cable entry



Fig. 3: Connection steps 5 and 6

- 1 Single chamber housing
- 2 Double chamber housing

6. Insert the wire ends into the terminals according to the wiring plan



#### Note:

Solid cores as well as flexible cores with wire end sleeves are inserted directly into the terminal openings. In case of flexible cores without end sleeves, press the terminal from above with a small screwdriver, the terminal opening is then free. When the screwdriver is released, the terminal closes again.

7. Check the hold of the wires in the terminals by lightly pulling on them
8. Connect the shielding to the internal ground terminal, connect the external ground terminal to potential equalisation



9. Tighten the compression nut of the cable entry gland. The seal ring must completely encircle the cable
  10. Reinsert the display and adjustment module, if one was installed
  11. Screw the housing lid back on
- The electrical connection is finished.

### 4.2 Single chamber housing



The following illustration applies to the non-Ex, Ex-ia and Ex-d version.

#### Electronics and connection compartment

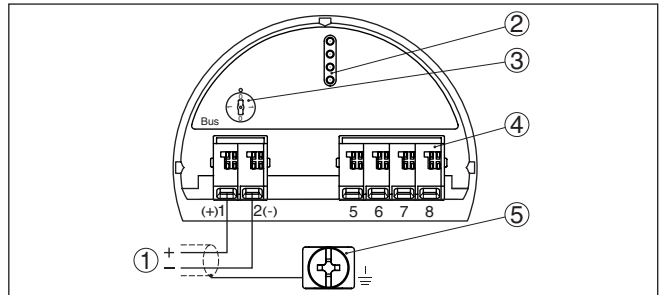

Fig. 4: Electronics and connection compartment - single chamber housing

- 1 Voltage supply, signal output
- 2 Contact pins for the display and adjustment module or interface adapter
- 3 Simulation switch ("1" = mode for simulation release)
- 4 For external display and adjustment unit
- 5 Ground terminal for connection of the cable screening

### 4.3 Double chamber housing



The following illustrations apply to the non-Ex as well as to the Ex-ia version.

#### Connection compartment

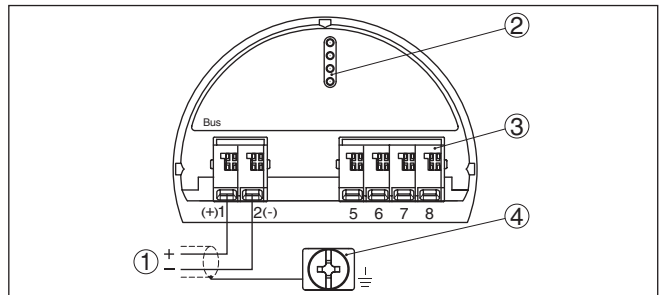

Fig. 5: Connection compartment - double chamber housing

- 1 Voltage supply, signal output
- 2 For display and adjustment module or interface adapter
- 3 For external display and adjustment unit
- 4 Ground terminal for connection of the cable screening

## 5 Set up with the display and adjustment module

### 5.1 Insert display and adjustment module

The display and adjustment module can be inserted into the sensor and removed again at any time. You can choose any one of four different positions - each displaced by 90°. It is not necessary to interrupt the power supply.

Proceed as follows:

1. Unscrew the housing lid
2. Place the display and adjustment module on the electronics in the desired position and turn it to the right until it snaps in.
3. Screw housing lid with inspection window tightly back on

Disassembly is carried out in reverse order.

The display and adjustment module is powered by the sensor, an additional connection is not necessary.



Fig. 6: Installing the display and adjustment module in the electronics compartment of the single chamber housing

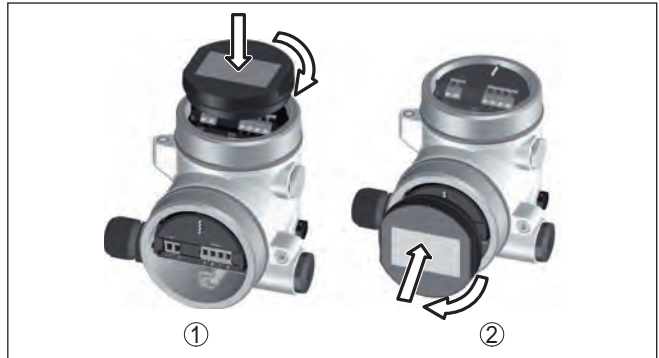

Fig. 7: Installing the display and adjustment module in the double chamber housing

- 1 In the electronics compartment
- 2 In the connection compartment



**Note:**

If you intend to retrofit the instrument with a display and adjustment module for continuous measured value indication, a higher lid with an inspection glass is required.

## 5.2 Parameter adjustment - Quick setup

To quickly and easily adapt the sensor to the application, select the menu item "Quick setup" in the start graphic on the display and adjustment module.



Carry out the following steps in the below sequence.

You can find "Extended adjustment" in the operating instructions VEGADIF 85.

### Quick setup - Presettings

#### Application

In this menu item, you select the application. The selection comprises level, flow, differential pressure, density and interface measurement.

#### Units

In this menu item you determine the adjustment and temperature unit as well as the unit of the static pressure of the instrument. Depending on the selected application in the menu item "Application", different adjustment units are available.

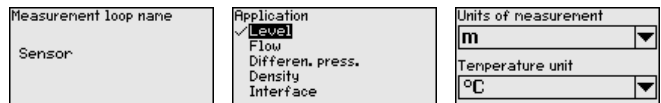

**Position correction**

In this menu item you compensate the influence of the installation position of the instrument (offset) on the measured value.

```
Differen. press.
Offset = 0,0000 bar
Act.    0,0071 bar
Static pressure
Offset = 0,0000 bar
Act.    0,0000 bar
```

```
Sensor mounting correction
Auto.correction
Edit differential pressure
Edit static pressure
```

**Quick setup - Level measurement****Min. adjustment**

In this menu item you carry out the min. adjustment for level.

Enter the percentage value and the corresponding pressure value for the min. level.

**Max. adjustment**

In this menu item you carry out the max. adjustment for level.

Enter the percentage value and the corresponding pressure value for the max. level.

```
Min. adjustment
0.00 %
≅
0.0500 bar
0.0000 bar
```



```
Max. adjustment
100.00 %
≅
1.0000 bar
-0.0001 bar
```

**Quick setup - Flow measurement****Min. adjustment**

In this menu item you carry out the min. adjustment for flow.

Enter the percentage value and the corresponding pressure value for the min. flow.

**Max. adjustment**

In this menu item you carry out the max. adjustment for flow.

Enter the percentage value and the corresponding pressure value for the max. flow.

**Linearisation**

In this menu item, you select the characteristics of the output signal.

```
Min. adjustment
0.00 %
≅
0.0500 bar
-0.0001 bar
```



```
Max. adjustment
100.00 %
≅
0.1000 bar
0.0000 bar
```



```
Linearization
✓ Linear
To square root
bi-directional linear
bi-directional square root
User prog.
```

**Quick setup - Differential pressure measurement****Zero adjustment**

In this menu item you carry out the Zero adjustment for the differential pressure.

Enter the corresponding pressure value for 0 %.

**Span adjustment**

In this menu item you carry out the Span adjustment for the differential pressure

Enter the corresponding pressure value for 100 %.

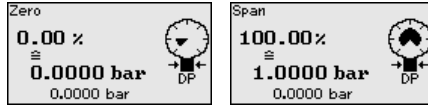

### Quick setup - Density measurement

#### Distance

In this menu item, you enter the installation distance between master and slave sensor.

#### Min. adjustment

In this menu item you carry out the min. adjustment for density.

Enter the percentage value and the corresponding density value for the min. density.

#### Max. adjustment

In this menu item you carry out the max. adjustment for density.

Enter the percentage value and the corresponding density value for the max. density.



### Quick setup - Interface measurement

#### Distance

In this menu item, you enter the installation distance between master and slave sensor.

#### Min. adjustment

In this menu item, you carry out the adjustment for the min. height of the interface.

Enter the percentage value and the corresponding height of the interface.

#### Max. adjustment

In this menu item, you carry out the adjustment for the max. height of the interface.

Enter the percentage value and the corresponding height of the interface.

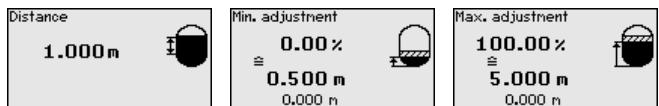

The quick setup is finished.

### Parameterization example

VEGADIF 85 always measures pressure independently of the process variable selected in the menu item "Application". To output the selected process variable correctly, an allocation of the output signal to 0 % and 100 % must be carried out (adjustment).

When using the application "Level", the hydrostatic pressure, e.g. with full and empty vessel, is entered as adjustment value. A superim-

posed pressure is detected by the minus side and automatically compensated. See the following example:

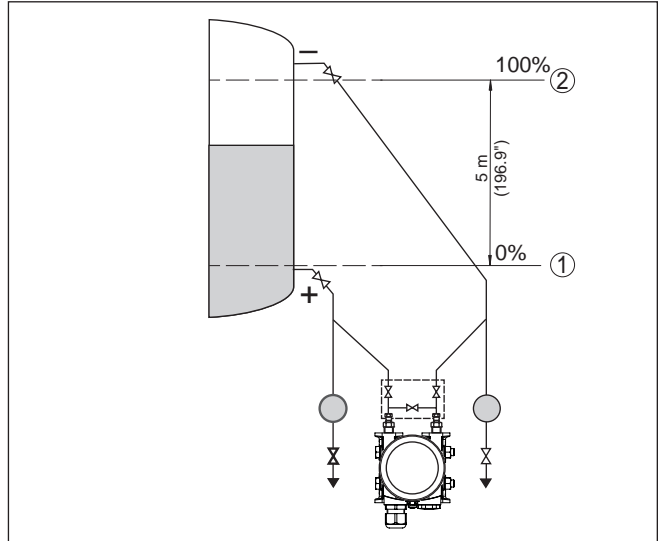

Fig. 8: Parameter adjustment example "Min./max. adjustment, level measurement"

- 1 Min. level = 0 % corresponds to 0.0 mbar
- 2 Max. level = 100 % corresponds to 490.5 mbar

If these values are not known, an adjustment with filling levels of e.g. 10 % and 90 % is also possible. By means of these settings, the real filling height is then calculated.

The actual product level during this adjustment is not important, because the min./max. adjustment is always carried out without changing the product level. These settings can be made ahead of time without the instrument having to be installed.

### 5.3 Parameter adjustment - Extended adjustment

For technically demanding measuring points, you can carry out extended settings in "Extended adjustment".

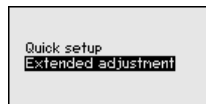

#### Main menu

The main menu is divided into five sections with the following functions:

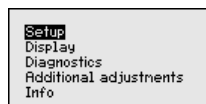

**Setup:** Settings, e.g., for measurement loop name, application, units, position correction, adjustment, signal output

**Display:** Settings, e.g., for language, measured value display, lighting

**Diagnosis:** Information, e.g. on instrument status, pointer, measurement reliability, simulation

**Additional adjustments:** PIN, date/time, reset, copy function

**Info:** Instrument name, hardware and software version, date of manufacture, device ID, sensor features



**Note:**

For optimum adjustment of the measuring point, the individual sub-menu items in the main menu item "Setup" should be selected one after the other and provided with the correct parameters. If possible, go through the items in the given sequence.

The procedure is described below.

The following submenu points are available:

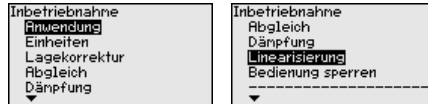

The submenu points are described below.

### 5.4 Menu overview

**Setup**

Menu item	Parameter	Default value
Application	Application	Level
Units	Unit of measurement	mbar (with nominal measuring range ≤ 400 mbar) bar (with nominal measuring ranges ≥ 1 bar)
	Temperature unit	°C
Position correction		0.00 bar
Adjustment	Zero/Min. adjustment	0.00 bar 0.00 %
	Span/Max. adjustment	Nominal measuring range in bar 100.00 %
Damping	Integration time	1 s
Linearisation		Linear
Lock adjustment		Released

**Display**

Menu item	Default value
Menu language	Order-specific
Displayed value 1	Signal output in %

Menu item	Default value
Displayed value 2	Measuring cell temperature in °C
Backlight	Switched on

## Diagnostics

Menu item	Parameter	Default value
Sensor status		-
Peak value, pressure		Actual measured value
Peak value, temperature		Actual temperature values from measuring cell, electronics
Simulation		Process pressure

## Additional adjustments

Menu item	Parameter	Default value
PIN		0000
Date/Time		Actual date/Actual time
Copy instrument settings		
Special parameters		No reset
Scaling	Scaling size	Volume in l
	Scaling format	0 % corresponds to 0 l 100 % corresponds to 0 l
DP flow element	Unit	kg/s
	Adjustment	0 % corresponds to 0 kg/s 100 % corresponds to 1 kg/s

## Info

Menu item	Parameter
Device name	Device name
Instrument version	Hardware and software version
Factory calibration date	Date
Device ID	Identification number of the instrument on a Foundation Fieldbus system
Sensor characteristics	Order-specific characteristics



## 6 Set up with smartphone/tablet, PC/ notebook via Bluetooth

### 6.1 Preparations

#### Activate Bluetooth

Make sure that the Bluetooth function of the display and adjustment module is activated. For this, the switch on the bottom side must be set to "On".

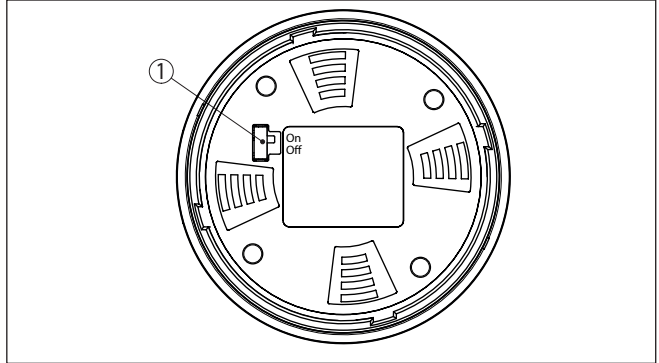

Fig. 9: Activate Bluetooth

1 Switch

On = Bluetooth active

Off = Bluetooth not active

#### Change sensor PIN

The security concept of Bluetooth operation absolutely requires that the default setting of the sensor PIN be changed. This prevents unauthorized access to the sensor.

The default setting of the sensor PIN is "0000". First of all you have to change the sensor PIN in the adjustment menu of the sensor, e.g. to "1111":

- Go to setup via the extended operation

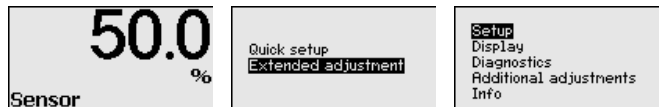

- Lock operation by changing sensor PIN

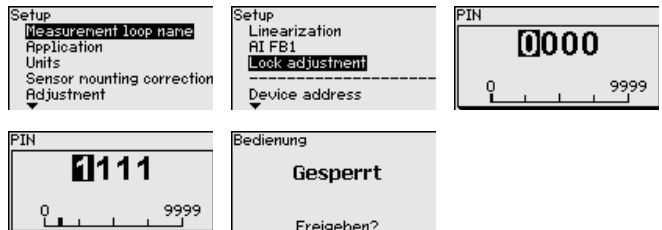

- Enable operation by entering the sensor PIN once more

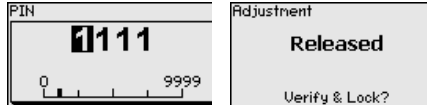

After entering the changed sensor PIN once again, sensor operation is enabled again. For access (authentication) with Bluetooth, the changed PIN is still effective.



**Information:**

Bluetooth communication functions only if the actual sensor PIN differs from the default setting "0000".

## 6.2 Connecting

### Preparations

#### Smartphone/Tablet

Start the adjustment app and select the function "Setup". The smartphone/tablet searches automatically for Bluetooth-capable instruments in the area.

#### PC/Notebook

Start PACTware and the VEGA project assistant. Select the device search via Bluetooth and start the search function. The device automatically searches for Bluetooth-capable devices in the vicinity.

### Connecting

The message "*Instrument search running*" is displayed. All devices found are listed in the operating window. The search is automatically continued continuously.

Select in the device list the requested device. The message "*Connecting*" is displayed.

### Authenticate

For the first connection, the operating device and the sensor must authenticate each other. After successful authentication, the next connection functions without authentication.

For authentication, enter in the next menu window the 4-digit sensor PIN.

## 6.3 Sensor parameter adjustment

The sensor parameterization is carried out via the adjustment app on the smartphone/tablet or the DTM on the PC/notebook.

App view

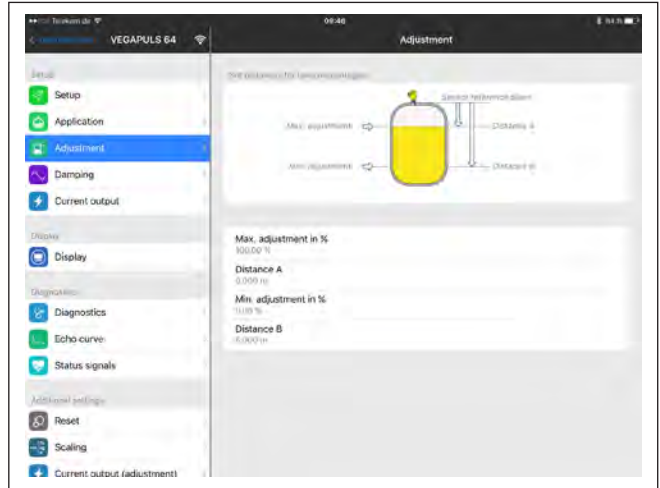

Fig. 10: Example of an app view - Setup sensor adjustment

## 7 Supplement

### 7.1 Technical data

#### Output variable

Output signal	digital output signal, Foundation Fieldbus protocol
Transmission rate	31.25 Kbit/s
Damping (63 % of the input variable)	0 ... 999 s, adjustable
Channel Numbers	
– Channel 1	Process value
– Channel 8	Electronics temperature
Current value	
– Non-Ex, Ex-ia and Ex-d instruments	12 mA, $\pm 0.5$ mA

#### Electromechanical data - version IP66/IP67 and IP66/IP68 (0.2 bar)<sup>1)</sup>

##### Options of the cable entry

– Cable entry	M20 x 1.5; ½ NPT
– Cable gland	M20 x 1.5, ½ NPT (cable $\varnothing$ see below table)
– Blind plug	M20 x 1.5; ½ NPT
– Closing cap	½ NPT

Material cable gland/Seal insert	Cable diameter			
	5 ... 9 mm	6 ... 12 mm	7 ... 12 mm	10 ... 14 mm
PA/NBR	●	●	–	●
Brass, nickel-plated/NBR	●	●	–	–
Stainless steel/NBR	–	–	●	–

##### Wire cross-section (spring-loaded terminals)

– Massive wire, stranded wire	0.2 ... 2.5 mm <sup>2</sup> (AWG 24 ... 14)
– Stranded wire with end sleeve	0.2 ... 1.5 mm <sup>2</sup> (AWG 24 ... 16)

#### Voltage supply

Operating voltage $U_B$	9 ... 32 V DC
Operating voltage $U_B$ with lighting switched on	13.5 ... 32 V DC
Power supply by/max. number of sensors	Fieldbus/32

<sup>1)</sup> IP66/IP68 (0.2 bar), only with absolute pressure.

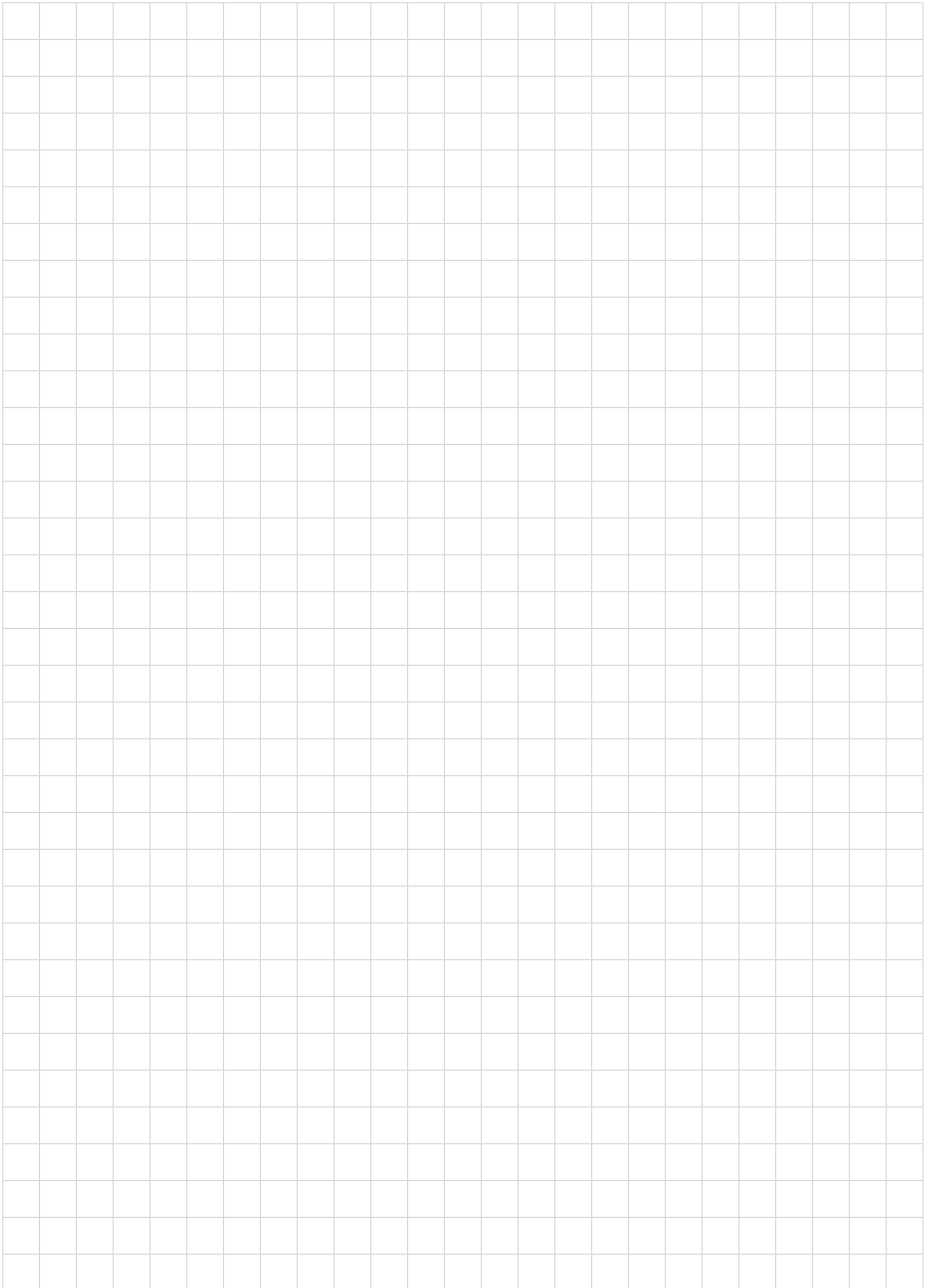



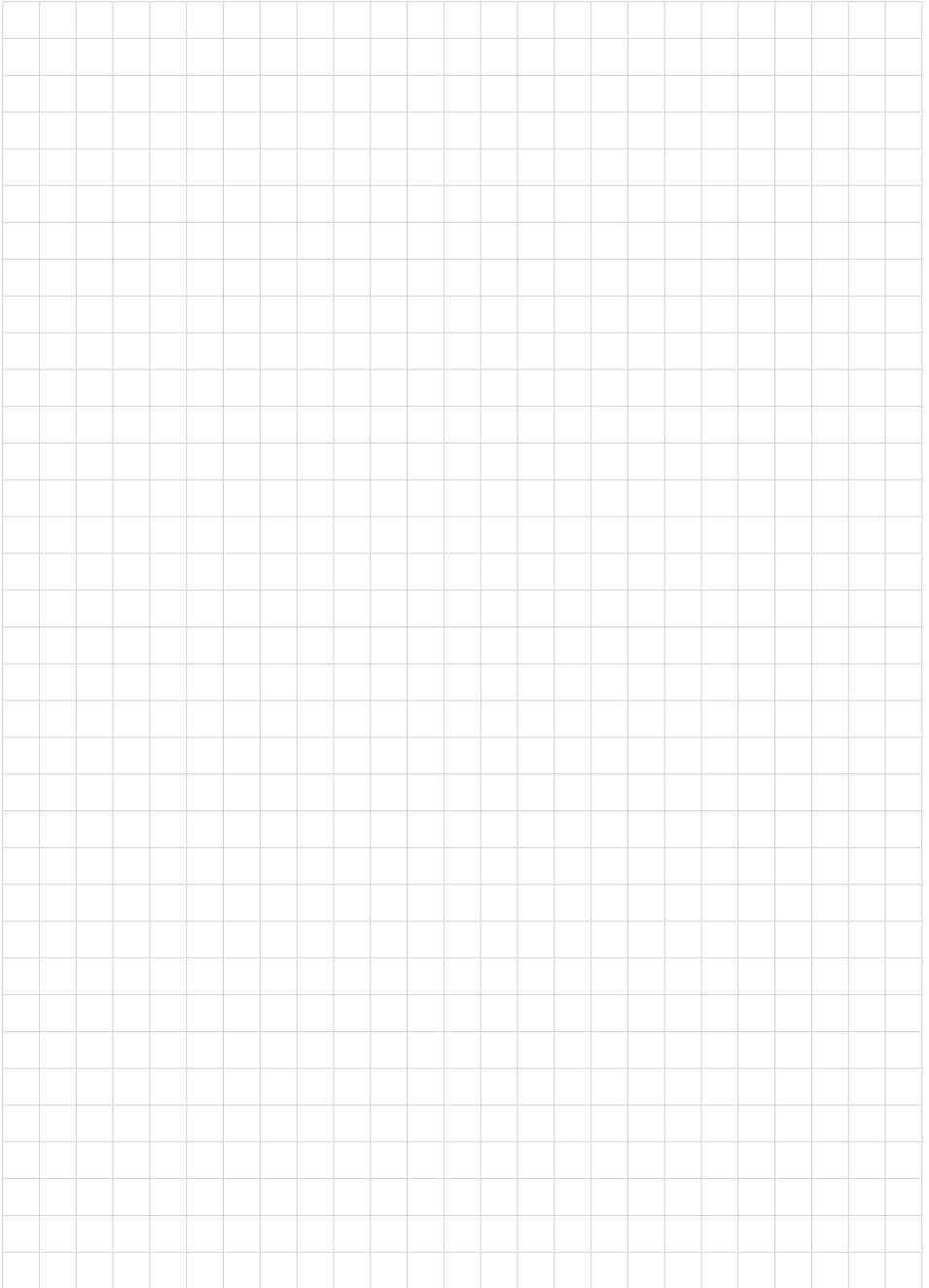

Printing date:

# VEGA

All statements concerning scope of delivery, application, practical use and operating conditions of the sensors and processing systems correspond to the information available at the time of printing.

Subject to change without prior notice

© VEGA Grieshaber KG, Schiltach/Germany 2020



53576-EN-200924

VEGA Grieshaber KG  
Am Hohenstein 113  
77761 Schiltach  
Germany

Phone +49 7836 50-0  
Fax +49 7836 50-201  
E-mail: [info.de@vega.com](mailto:info.de@vega.com)  
[www.vega.com](http://www.vega.com)