

## Safety instructions

### CCOE approval

### VEGABAR 81, 82, 83, 86, 87

Intrinsic safety

4 ... 20 mA

4 ... 20 mA/HART

4 ... 20 mA/HART SIL

Profibus PA

Foundation Fieldbus

Slave Sensor for electronic differential pressure measurement (SIL)

Additional current output



Document ID: 62627



# VEGA

## Contents

<b>1</b>	<b>Area of applicability.....</b>	<b>3</b>
<b>2</b>	<b>General information.....</b>	<b>3</b>
<b>3</b>	<b>Technical data .....</b>	<b>4</b>
<b>4</b>	<b>Application conditions .....</b>	<b>11</b>
<b>5</b>	<b>Protection against static electricity .....</b>	<b>14</b>
<b>6</b>	<b>Use of an overvoltage arrester .....</b>	<b>14</b>
<b>7</b>	<b>Grounding.....</b>	<b>14</b>
<b>8</b>	<b>Impact and friction sparks .....</b>	<b>15</b>
<b>9</b>	<b>Material resistance .....</b>	<b>15</b>
<b>10</b>	<b>Mounting with external display unit VEGADIS 61/81.....</b>	<b>15</b>
<b>11</b>	<b>Installation/construction .....</b>	<b>15</b>
<b>12</b>	<b>Installation of the VEGABAR series 80 with separate housing .....</b>	<b>15</b>

Supplementary documentation:

- Operating instructions VEGABAR 81, 82, 83, 86, 87
- Quick setup guide VEGABAR 81, 82, 83, 86, 87
- Letter P444445 By Government of India (Document ID: 62629)

Editing status: 2019-09-11

## **1 Area of applicability**

These safety instructions apply to the pressurer transmitters VEGABAR B81/82/83/86/87.DC/U/O with integrated electronics Z (4 ... 20 mA), H (4 ... 20 mA/HART), A (4 ... 20 mA/HART with SIL qualification), S, T (differential pressure measurement), P (Profibus PA), F (Foundation Fieldbus) without supplementary electronics (X) according to Letter P444445/1 By Government of India (certificate number on the type label) and for all instruments with the number of the safety instruction (62627) on the type label.

## **2 General information**

The pressure-based measuring instruments VEGABAR B8\*.DC/U/O are also used for pressure and level measurement in hazardous areas.

The measured products can also be combustible liquids, gases, mist or vapour.

The VEGABAR B8\*.DC/U/O consist of an electronics housing with integrated electronics module, a process connection element and a sensor, the pressure measuring cell with optionally connected chemical seal. As an option, the display and adjustment module can also be mounted.

The VEGABAR B8\*.DC/U/O are suitable for use in hazardous atmospheres of all combustible materials of explosion group IIA, IIB and IIC for applications requiring instruments of EPL Ga, EPL Ga/Gb or EPL Gb.

If the VEGABAR B8\*.DC/U/O are installed and operated in hazardous areas, the general Ex installation regulations IEC 60079-14 as well as these safety instructions must be observed.

The operating instructions as well as the installation regulations and standards that apply for explosion protection of electrical systems must always be observed.

The installation of explosion-endangered systems must always be carried out by qualified personnel.

### **EPL Ga instrument**

The VEGABAR B8\*.DC/U/O are installed in hazardous areas requiring EPL Ga instruments.

### **EPL Ga/Gb instrument**

The process connection element is installed in the separating wall, which separates areas in which EPL Ga or EPL Gb instruments are required. The electronics housing is installed in hazardous areas, requiring EPL Gb instruments. The sensor is installed in hazardous areas requiring EPL Ga instruments.

### **EPL Gb instrument**

The VEGABAR B8\*.DC/U/O are installed in hazardous areas requiring EPL Gb instruments.

### **Type of protection marking:**

Ex ia IIC T6 ... T1 Ga/Gb

### 3 Technical data

#### Electrical data

**VEGABAR B8\*.DC/U/O with integrated electronics Z (4 ... 20 mA), H (4 ... 20 mA/HART) or A (4 ... 20 mA/HART with SIL qualification), version with single chamber housing A, K, V or 8**

Supply and signal circuit: (terminals 1[+], 2[-] in the "Ex-i" electronics compartment or plug connection)	<p>In type of protection intrinsic safety Ex ia IIC/IIB</p> <p>Only for connection to a certified, intrinsically safe circuit.</p> <p>Maximum values:</p> <ul style="list-style-type: none"> <li>● <math>U_i = 30\text{ V}</math></li> <li>● <math>I_i = 131\text{ mA}</math></li> <li>● <math>P_i = 983\text{ mW}</math></li> </ul> <p>The effective internal capacitance <math>C_i</math> is negligibly small.</p> <p>In the version with permanently mounted connection cable, <math>C_{i\text{ wire/wire}} = 150\text{ pF/m}</math> and <math>C_{i\text{ wire/screen}} = 270\text{ pF/m}</math> must be taken into account.</p> <p>The effective inner inductance <math>L_i</math> is <math>L_i \leq 5\text{ }\mu\text{H}</math>. In the version with permanently mounted connection cable, <math>L_i = 0.62\text{ }\mu\text{H/m}</math> must also be taken into account.</p>
--	---

**VEGABAR B8\*.DC/U/O with integrated electronics Z (4 ... 20 mA), H (4 ... 20 mA/HART) or A (4 ... 20 mA/HART with SIL qualification), version with double chamber housing D, W or R**

Power supply and signal circuit: (terminal 1[+], 2[-] in the "Ex-i" connection compartment)	<p>In type of protection intrinsic safety Ex ia IIC/IIB</p> <p>Only for connection to a certified, intrinsically safe circuit.</p> <p>Maximum values:</p> <ul style="list-style-type: none"> <li>● <math>U_i = 30\text{ V}</math></li> <li>● <math>I_i = 131\text{ mA}</math></li> <li>● <math>P_i = 983\text{ mW}</math></li> </ul> <p>The effective internal capacitance <math>C_i</math> is negligibly small.</p> <p>In the version with permanently mounted connection cable, <math>C_{i\text{ wire/wire}} = 150\text{ pF/m}</math> and <math>C_{i\text{ wire/screen}} = 270\text{ pF/m}</math> must be taken into account.</p> <p>The effective inner inductance <math>L_i</math> with the double chamber version is <math>L_i \leq 10\text{ }\mu\text{H}</math>. In the version with permanently mounted connection cable, <math>L_i = 0.62\text{ }\mu\text{H/m}</math> must also be taken into account.</p>
---	--

---

## VEGABAR B8\*.DC/U/O with integrated electronics Z (4 ... 20 mA), H (4 ... 20 mA/HART) or A (4 ... 20 mA/HART with SIL qualification)

---

Indicating and adjustment circuit: (terminals 5, 6, 7, 8)<sup>1)2)3)</sup>

In type of protection intrinsic safety Ex ia IIC

For connection to the intrinsically safe circuit of the corresponding external display unit VEGADIS 61/81 or for connection of a VEGABAR B80 with integrated electronics S or T for differential pressure measurement.

The rules for the interconnection of intrinsically safe circuits between VEGABAR B8\*.DC/U/O and the external indicating unit VEGADIS 61/81 or VEGABAR B8\* with electronics S or T are fulfilled, provided that the total inductance and total capacitance of the connection cable between VEGABAR B8\*.DC/U/O and the external indicating unit VEGADIS 61/81 or VEGABAR B8\* with electronics S or T  $L_{\text{cable}} = 330 \mu\text{H}$  and  $C_{\text{cable}} = 1.98 \mu\text{F}$  are not exceeded.

When using the delivered VEGA connection cable between VEGABAR B8\*.DC/U/O and the external indicating unit VEGADIS 61/81 or VEGABAR B8\* with electronics S or T, the following listed cable inductances  $L_i$  and cable capacitances  $C_i$  must be taken into account with a cable length  $\geq 50$  m.

- $L_i = 0.62 \mu\text{H/m}$
- $C_{i \text{ wire/wire}} = 150 \text{ pF/m}$
- $C_{i \text{ wire/screen}} = 270 \text{ pF/m}$

### Intrinsically safe circuit for the display and adjustment module

## VEGABAR B8\*.DC/U/O with integrated electronics Z (4 ... 20 mA), H (4 ... 20 mA/HART) or A (4 ... 20 mA/HART with SIL qualification), version with single chamber housing A, K, V or 8

---

Circuit for the display and adjustment module: (spring contacts in the "Ex-ii" electronics compartment)

In type of protection intrinsic safety Ex ia IIC

Only for connection to the display and adjustment module PLICSCOM or VEGACONNECT.

---

## VEGABAR B8\*.DC/U/O with integrated electronics Z (4 ... 20 mA), H (4 ... 20 mA/HART) or A (4 ... 20 mA/HART with SIL qualification), version with double chamber housing D, W or R

---

Circuit for the display and adjustment module: (spring contacts in the "Ex-i" connection compartment)

In type of protection intrinsic safety Ex ia IIC

Only for connection to the display and adjustment module PLICSCOM or VEGACONNECT.

or

- 1) In the "Ex-ii" electronics compartment with VEGABAR in version with single chamber housing A, K, V or 8.
- 2) In the "Ex-i" connection compartment with VEGABAR in version with double chamber housing D, W or R.
- 3) Additional plug connection with VEGABAR in version with double chamber housing D, W, R and housing version/protection P (with M12 x 1 for VEGADIS).

Circuit for the display and adjustment module: (spring contacts in the "Ex-i" electronics compartment)

In type of protection intrinsic safety Ex ia IIC

Only for connection to the display and adjustment module PLICSCOM or VEGACONNECT.

In the double chamber version, the display and adjustment module PLICSCOM or VEGACONNECT must only be equipped in the connection compartment, if there is no external VEGA display unit VEGADIS 61/81 or VEGABAR B80 with electronics S, T connected.

---

**VEGABAR B8\*.DC/U/O with integrated electronics Z (4 ... 20 mA), H (4 ... 20 mA/HART) or A (4 ... 20 mA/HART with SIL qualification), version with double chamber housing D, W or R with housing version/protection P (with M12 x 1 for VEGADIS)**

---

Circuit for the display and adjustment module: (spring contacts in the "Ex-i" connection compartment)

In type of protection intrinsic safety Ex ia IIC

Only for connection to the display and adjustment module PLICSCOM or VEGACONNECT.

In the double chamber version, the display and adjustment module PLICSCOM or VEGACONNECT must only be equipped in the connection compartment, if there is no external VEGA display unit VEGADIS 61/81 or VEGABAR B80 with electronics S, T connected.

---

**VEGABAR B8\*.DC/U/O with integrated electronics P (Profibus PA), F (Foundation Fieldbus), version with single chamber housing A, K, V or 8**

---

Supply and signal circuit: (terminals 1[+], 2[-] in the "Ex-i" electronics compartment or plug connection)

In type of protection intrinsic safety Ex ia IIC

Only for connection to a certified, intrinsically safe circuit.

Maximum values:

- $U_i = 17.5 \text{ V}$
- $I_i = 500 \text{ mA}$
- $P_i = 5.5 \text{ W}$

The instrument is suitable for connection to a Fieldbus system according to the FISCO model (IEC 60079-11), e.g. Profibus PA.

or

- $U_i = 24 \text{ V}$
- $I_i = 250 \text{ mA}$
- $P_i = 1.2 \text{ W}$

The effective internal capacitance  $C_i$  is negligibly small.

The effective internal inductance  $L_i$  is negligibly small.

In the version with fix-mounted connection cable, the following cable inductances  $L_i'$  and cable capacitances  $C_i$  have to be taken into account.

- $L_i = 0.62 \text{ } \mu\text{H/m}$
- $C_{i \text{ wire/wire}} = 150 \text{ pF/m}$
- $C_{i \text{ wire/screen}} = 270 \text{ pF/m}$

---

## VEGABAR B8\*.DC/U/O with integrated electronics P (Profibus PA), F (Foundation Fieldbus), version with double chamber housing D, W or R

---

Power supply and signal circuit: (terminal 1[+], 2[-] in the "Ex-i" connection compartment)

In type of protection intrinsic safety Ex ia IIC

Only for connection to a certified, intrinsically safe circuit.

Maximum values:

- $U_i = 17.5 \text{ V}$
- $I_i = 500 \text{ mA}$
- $P_i = 5.5 \text{ W}$

The instrument is suitable for connection to a Fieldbus system according to the FISCO model (IEC 60079-11), e.g. Profibus PA.

or

- $U_i = 24 \text{ V}$
- $I_i = 250 \text{ mA}$
- $P_i = 1.2 \text{ W}$

The effective internal capacitance  $C_i$  is negligibly small.

The effective internal inductance is  $L_i \leq 5 \mu\text{H}$ .

In the version with fix-mounted connection cable, the following cable inductances  $L_i'$  and cable capacitances  $C_i$  have to be taken into account.

- $L_i = 0.62 \mu\text{H/m}$
- $C_{i \text{ wire/wire}} = 150 \text{ pF/m}$
- $C_{i \text{ wire/screen}} = 270 \text{ pF/m}$

---

**VEGABAR B8\*.DC/U/O with integrated electronics P (Profibus PA), F (Foundation Fieldbus)**

---

Indicating and adjustment circuit: (terminals 5, 6, 7, 8)<sup>4)5)6)</sup>

In type of protection intrinsic safety Ex ia IIC

For connection to the intrinsically safe circuit of the corresponding external display unit VEGADIS 61/81 or for connection of a VEGABAR B80 with integrated electronics S or T for differential pressure measurement.

The rules for the interconnection of intrinsically safe circuits between VEGABAR B8\*.DC/U/O and the external indicating unit VEGADIS 61/81 or VEGABAR B8\* with electronics S or T are fulfilled, provided that the total inductance and total capacitance of the connection cable between VEGABAR B8\*.DC/U/O and the external indicating unit VEGADIS 61/81 or VEGABAR B8\* with electronics S or T are not exceeded.

- $L_{\text{cable}} = 212 \mu\text{H}$
- $C_{\text{cable}} = 1.98 \mu\text{F}$

When using the delivered VEGA connection cable between VEGABAR B8\*.DC/U/O and the external indicating unit VEGADIS 61/81 or VEGABAR B8\* with electronics S or T, the following listed cable inductances  $L_i$  and cable capacitances  $C_i$  must be taken into account with a cable length  $\geq 50$  m.

- $L_i = 0.62 \mu\text{H/m}$
- $C_{i \text{ wire/wire}} = 150 \text{ pF/m}$
- $C_{i \text{ wire/screen}} = 270 \text{ pF/m}$

---

**VEGABAR B8\*.DC/U/O with integrated electronics P (Profibus PA), F (Foundation Fieldbus), version with single chamber housing A, K, V or 8**

---

Circuit for the display and adjustment module: (spring contacts in the "Ex-i" electronics compartment)

In type of protection intrinsic safety Ex ia IIC

Only for connection to the display and adjustment module PLICSCOM or VEGACONNECT.

---

**VEGABAR B8\*.DC/U/O with integrated electronics P (Profibus PA), F (Foundation Fieldbus), version with double chamber housing D, W or R**

---

Circuit for the display and adjustment module: (spring contacts in the "Ex-i" connection compartment)

In type of protection intrinsic safety Ex ia IIC

Only for connection to the display and adjustment module PLICSCOM or VEGACONNECT.

or

<sup>4)</sup> In the "Ex-i" electronics compartment with VEGABAR in version with single chamber housing A, K, V or 8.  
<sup>5)</sup> In the "Ex-i" connection compartment with VEGABAR in version with double chamber housing D, W or R.  
<sup>6)</sup> Additional plug connection with VEGABAR in version with double chamber housing D, W, R and housing version/protection P (with M12 x 1 for VEGADIS).



Circuit for the display and adjustment module: (spring contacts in the "Ex-i" electronics compartment)

In type of protection intrinsic safety Ex ia IIC

Only for connection to the display and adjustment module PLICSCOM or VEGACONNECT.

In the double chamber version, the display and adjustment module PLICSCOM or VEGACONNECT must only be equipped in the connection compartment, if there is no external VEGA display unit VEGADIS 61/81 or VEGABAR B80 with electronics S, T connected.

---

**VEGABAR B8\*.DC/U/O with integrated electronics Z (4 ... 20 mA), H (4 ... 20 mA/HART) or A (4 ... 20 mA/HART with SIL qualification), version with double chamber housing D, W or R with housing version/protection P (with M12 x 1 for VEGADIS)**

---

Circuit for the display and adjustment module: (spring contacts in the "Ex-i" connection compartment)

In type of protection intrinsic safety Ex ia IIC

Only for connection to the display and adjustment module PLICSCOM or VEGACONNECT.

In the double chamber version, the display and adjustment module PLICSCOM or VEGACONNECT must only be equipped in the connection compartment, if there is no external VEGA display unit VEGADIS 61/81 or VEGABAR B80 with electronics S, T connected.

---

**VEGABAR B8\*.DC/U/O with integrated electronics S or T, only version with single chamber housing**

---

Power supply and signal circuit: (terminals 5, 6, 7, 8 in the electronics compartment)

In type of protection intrinsic safety Ex ia IIC

For connection to the intrinsically safe circuit of a VEGABAR B8\*.C\*\*\*\*\* with integrated electronics H, A, P, F for differential pressure measurement.

The rules for the interconnection of intrinsically safe circuits between VEGABAR B80 with electronics S or T and VEGABAR B8\*.C\*\*\*\*\* are fulfilled, provided that the total inductance and total capacitance of the connection cable between VEGABAR B8\*.C\*\*\*\*\* and VEGABAR B8\* with electronics S or T,  $L_{\text{cable}} = 330 \mu\text{H}$  and  $C_{\text{cable}} = 2.00 \mu\text{F}$ , is not exceeded.

When using the delivered VEGA connection cable between VEGABAR B8\*.DC/U/O and the external indicating unit VEGADIS 61/81 or VEGABAR B8\* with electronics S or T, the following listed cable inductances  $L_i$  and cable capacitances  $C_i$  must be taken into account with a cable length  $\geq 50 \text{ m}$ .

- $L_i = 0.62 \mu\text{H/m}$
- $C_{i \text{ wire/wire}} = 150 \text{ pF/m}$
- $C_{i \text{ wire/screen}} = 270 \text{ pF/m}$

---

**VEGABAR B8\*.DC/U/O with integrated electronics H (4 ... 20 mA/HART) or A (4 ... 20 mA/HART with SIL qualification) and with supplementary electronics (Z)**

---

Supply and signal circuit I: (terminals 1[+], 2[-] in the "Ex-i" connection compartment or plug connection)

In type of protection intrinsic safety Ex ia IIC/IIB

Only for connection to a certified, intrinsically safe circuit.

Maximum values:

- $U_i = 30 \text{ V}$
- $I_i = 131 \text{ mA}$
- $P_i = 983 \text{ mW}$

The effective internal capacitance  $C_i$  is negligibly small.

In the version with permanently mounted connection cable,  $C_{i \text{ wire/wire}} = 150 \text{ pF/m}$  and  $C_{i \text{ wire/screen}} = 270 \text{ pF/m}$  must be taken into account.

The effective inner inductance  $L_i$  is  $L_i \leq 5 \text{ }\mu\text{H}$ . In the version with permanently mounted connection cable,  $L_i = 0.62 \text{ }\mu\text{H/m}$  must also be taken into account.

Power supply and signal circuit II: (terminal 7[+], 8[-] in the "Ex-i" connection compartment)

In type of protection intrinsic safety Ex ia IIC/IIB

Only for connection to a certified, intrinsically safe circuit.

Maximum values:

- $U_i = 30 \text{ V}$
- $I_i = 131 \text{ mA}$
- $P_i = 983 \text{ mW}$

The effective internal capacitance  $C_i$  is negligibly small.

In the version with permanently mounted connection cable,  $C_{i \text{ wire/wire}} = 150 \text{ pF/m}$  and  $C_{i \text{ wire/screen}} = 270 \text{ pF/m}$  must be taken into account.

The effective inner inductance  $L_i$  is  $L_i \leq 5 \text{ }\mu\text{H}$ . In the version with permanently mounted connection cable,  $L_i = 0.62 \text{ }\mu\text{H/m}$  must also be taken into account.

Display and adjustment circuit: (plug connection of the double chamber housing)

In type of protection intrinsic safety Ex ia IIC

For connection to the intrinsically safe circuit of the corresponding external display unit VEGADIS 61/81.

The rules for the interconnection of intrinsically safe circuits between VEGABAR B8\*.DC/U/O and the external indicating unit VEGADIS 61/81 are fulfilled, provided that the total inductance and total capacitance of the connection cable between VEGABAR B8\*.DC/U/O and the external indicating unit VEGADIS 61/81  $L_{\text{cable}} = 330 \text{ }\mu\text{H}$  and  $C_{\text{cable}} = 1.98 \text{ }\mu\text{F}$  are not exceeded.

When using the delivered VEGA connection cable between VEGABAR B8\*.DC/U/O and the external indicating unit VEGADIS 61/81, the following listed cable inductances  $L_i$  and cable capacitances  $C_i$  must be taken into account.

- $L_i = 0.62 \text{ }\mu\text{H/m}$
- $C_{i \text{ wire/wire}} = 150 \text{ pF/m}$
- $C_{i \text{ wire/screen}} = 270 \text{ pF/m}$

Circuit for the display and adjustment module: (spring contacts in the "Ex-i" electronics compartment)

In type of protection intrinsic safety Ex ia IIC

Only for connection to the display and adjustment module PLICSCOM or VEGACONNECT.

## VEGABAR B8\*.DC/U/OVersion with separate cable outlet

Circuit between sensor unit and external electronics (terminal 1- yellow, terminal 2 - white, terminal 3 - red, terminal 4 - black)

In type of protection intrinsic safety Ex ia IIC

With VEGABAR B8\*.AC in the version with fix mounted cable on the sensor unit and external electronics, the supplied cable between the external housing and the sensor unit must not exceed a length of 180 m.

The intrinsically safe circuits for external connections are electrically separated from parts which can be grounded.

The intrinsically safe circuits to the sensor are galvanically connected to ground potential.

The metallic parts of VEGABAR B8\*.DC/U/O are electrically connected with the earth terminals.

For applications requiring equipment of type EPL Ga or EPL Ga/Gb, the intrinsically safe power supply and signal circuit must correspond to protection class ia.

For applications requiring EPL Ga resp. EPL Ga/Gb instruments the VEGABAR B8\*.DC/U/O is preferably connected to appropriate instruments with electrically isolated, intrinsically safe circuits.

## 4 Application conditions

**VEGABAR B8\*.DC/U/O with integrated electronics Z (4 ... 20 mA), H (4 ... 20 mA/HART) or A (4 ... 20 mA/HART with SIL qualification), S, T (electronic differential pressure measurement), P (Profibus PA), F (Foundation Fieldbus)**

The max. permissible ambient temperatures depending on the temperature classes are specified in the following tables.

### EPL Ga instrument

Temperature class	Ambient temperature on the sensor and electronics
T6	-20 ... +23 °C
T5, T4, T3, T2, T1	-20 ... +60 °C

For applications requiring instruments of EPL Ga the process pressure of the media must be between 0.8 ... 1.1 bar. The prerequisites for operation in the absence of explosive mixtures can be found in the manufacturer information.

### EPL Ga/Gb instrument

Temperature class	Ambient temperature on the electronics	Product temperature on the sensor
T6	-50 ... +39 °C	-20 ... +23 °C
T5, T4, T3, T2, T1	-50 ... +70 °C	-20 ... +60 °C

For applications requiring EPL Ga/Gb instruments the process pressure of the media must be between 0.8 ... 1.1 bar. If the VEGABAR B8\*.DC/U/O are operated at temperatures higher than those specified in the above table, please make sure through appropriate measures that there is no danger of ignition from the hot surfaces. The maximum temperature on the electronics/housing should not exceed the values specified in the above table. The application conditions during operation in

areas with no explosive mixtures are stated in the manufacturer information.

**EPL Gb instrument, VEGABAR 82, VEGABAR 83 with METEC measuring cell**

Temperature class	Ambient temperature on the electronics (Zone 1)	Product temperature range (sensor, zone 1)
T6	-50 ... +39 °C	-50 ... +39 °C
T5	-50 ... +70 °C	-50 ... +100 °C
T4	-50 ... +50 °C	-50 ... +135 °C
T3, T2, T1	-50 ... +50 °C	-50 ... +200 °C

**EPL Gb instrument, VEGABAR 83 version with piezoresistive/strain gauge measuring cell, version without cooling element**

Temperature class	Ambient temperature on the electronics (Zone 1)	Product temperature range (sensor, zone 1)
T6	-50 ... +39 °C	-50 ... +39 °C
T5	-50 ... +70 °C	-50 ... +85 °C
T4	-50 ... +40 °C	-50 ... +105 °C
T4, T3, T2, T1	-50 ... +30 °C	-50 ... +120 °C

**EPL Gb instrument, VEGABAR 81, VEGABAR 83 version with piezoresistive/strain gauge measuring cell, version with cooling element**

Temperature class	Ambient temperature on the electronics (Zone 1)	Product temperature range (sensor, zone 1)
T6	-50 ... +39 °C	-50 ... +39 °C
T5	-50 ... +70 °C	-50 ... +85 °C
T4	-50 ... +50 °C	-50 ... +120 °C
T3, T2, T1	-50 ... +40 °C	-50 ... +150 °C

If the VEGABAR B8\*.DC/U/O are operated at temperatures higher than those specified in the above table, please make sure through appropriate measures that there is no danger of ignition from the hot surfaces. The max. permissible temperature on the electronics/housing should not exceed the values specified in the above table. The application conditions during operation with no explosive mixtures present are stated in the manufacturer information.

## Temperature derating

### VEGABAR 82, version process temperature +130 °C

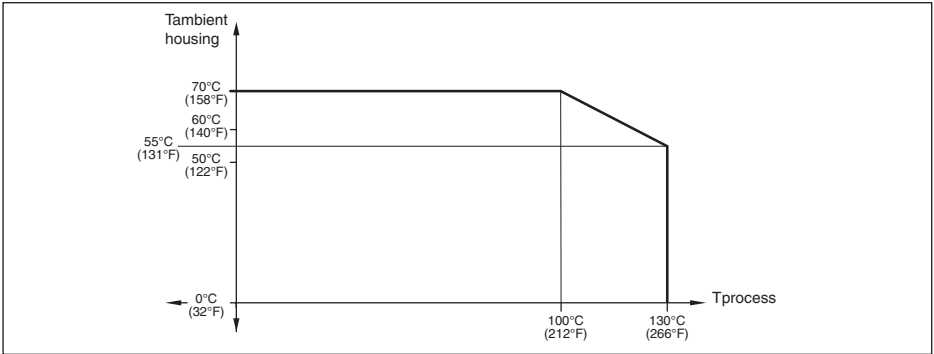

### VEGABAR 82, version process temperature +150 °C

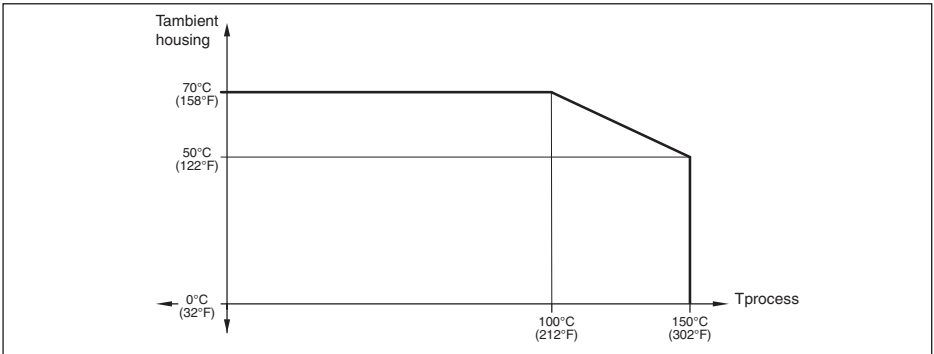

**VEGABAR 81, VEGABAR 83**

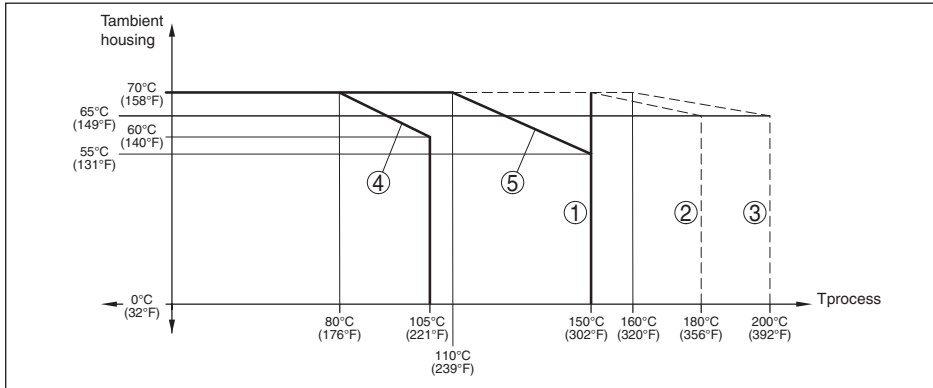

- 1 Version: METEC measuring cell, process temperature max. 150 °C
- 2 Version: METEC measuring cell, process temperature max. 180 °C
- 3 Version: METEC measuring cell, process temperature max. 200 °C
- 4 Version: Piezoresistive/strain gauge measuring cell, without cooling element
- 5 Version: Piezoresistive/strain gauge measuring cell, with cooling element

The temperature ranges for operation specified in the operating instruction must not be exceeded.

**5 Protection against static electricity**

The VEGABAR B8\*.DC/U/O in versions with electrostatically chargeable plastic parts, such as e.g. plastic housing, metal housing with inspection window, with plastic coated sensors, suspension cable or suspension hose, distance tube or connection cable with the separated version, a caution label points out the safety measures that must be taken with regard to electrostatic charges during operation.

WARNING - DO NOT OPEN WHEN AN  
EXPLOSIVE ATMOSPHERE IS PRESENT

Caution: Plastic parts! Danger of electrostatic charging!

- Avoid friction
- No dry cleaning
- Do not mount in areas with flowing, non-conductive products

**6 Use of an overvoltage arrester**

If necessary, a suitable overvoltage arrester can be connected in front of the VEGABAR B8\*.DC/U/O.

When used as EPL Ga or EPL Ga/Gb instrument, as far as necessary analogue, a suitable overvoltage arrester must be connected in front as protection against voltage surges according to IEC 60079-14.

**7 Grounding**

In order to avoid the danger of electrostatic charging of the metallic parts, the VEGABAR B8\*.DC/U/O, used as EPL Ga or EPL Ga/Gb instrument, must be electrostatically connected to the local potential equalisation (transfer resistance ≤ 1 MΩ), e.g. via the ground terminal.

## 8 Impact and friction sparks

When used as EPL Ga or EPL Ga/Gb instruments, the VEGABAR B8\*.DC/U/O in aluminium/titanium versions must be mounted in such a way that sparks from impact and friction between aluminium/titanium and steel (except stainless steel, if the presence of rust particles can be excluded) cannot occur.

## 9 Material resistance

For applications requiring instruments of type EPL Ga or EPL Ga/Gb the VEGABAR B8\*.DC/U/O must only be used in products against which the wetted materials are sufficiently resistant.

## 10 Mounting with external display unit VEGADIS 61/81

The intrinsically safe signal circuit between VEGABAR B8\*.DC/U/O and the external indicating unit VEGADIS 61/81 should be set up without grounding. The required insulation voltage is > 500 V AC. When using the VEGA connection cable included with the delivery, this requirement is fulfilled. If grounding of the cable screen is required, it must be carried out according to IEC 60079-14.

## 11 Installation/construction

The VEGABAR B8\*.DC/U/O have to be mounted such that the sensor is effectively secured against touching the vessel wall, under consideration of other vessel installations and flow conditions in the vessel. This applies especially to suspension pressure transmitters and versions with distance tube lengths over 3 m.

## 12 Installation of the VEGABAR series 80 with separate housing

With the version with separate housing of the pressure transmitter VEGABAR B8\*.DC/U/O, the potential equalization must be provided in the complete range of the connection cable between electronics housing and transmitter housing.

## Confirmation

Hereby the company VEGA Grieshaber KG declares that the approved CCOE devices have been manufactured in accordance with the ATEX approval mentioned in the attached CCOE certificate.

**VEGA Grieshaber KG**  
Am Hohenstein 113  
77761 Schiltach/Germany  
Tel. +49 7836 50-0  
E-mail: info@vega.com - www.vega.com

Printing date:

**VEGA**

All statements concerning scope of delivery, application, practical use and operating conditions of the sensors and processing systems correspond to the information available at the time of printing.

Subject to change without prior notice

© VEGA Grieshaber KG, Schiltach/Germany 2019

62627-EN-191129

VEGA Grieshaber KG  
Am Hohenstein 113  
77761 Schiltach  
Germany

Phone +49 7836 50-0  
Fax +49 7836 50-201  
E-mail: [info.de@vega.com](mailto:info.de@vega.com)  
[www.vega.com](http://www.vega.com)