

# Manufacturer declaration

## EHEDG and 3-A, Installation and Cleaning Instructions

Hygienic process fittings



Document ID: 63436



**VEGA**

## Contents

<b>1</b>	<b>About this document</b> .....	<b>3</b>
1.1	Function .....	3
1.2	Scope.....	3
<b>2</b>	<b>3-A-/EHEDG-Standards - Meaning and implementation</b> .....	<b>4</b>
<b>3</b>	<b>Instrument versions</b> .....	<b>5</b>
<b>4</b>	<b>Mounting</b> .....	<b>6</b>
<b>5</b>	<b>Maintenance, cleaning, appropriate use</b> .....	<b>8</b>
<b>6</b>	<b>Manufacturer declaration</b> .....	<b>9</b>
6.1	3-A .....	9
6.2	EHEDG .....	10
<b>7</b>	<b>3-A certificate</b> .....	<b>11</b>
<b>8</b>	<b>EHEDG certificate</b> .....	<b>16</b>

# 1 About this document

## 1.1 Function

This instructions manual provides the most important information needed for using of hygienic adapters.

**Hygienic adapter P in conjunction with VEGAPOINT 11, 21**  
according to "*EHEDG Doc. 2, Doc. 8, Doc. 10 and 3-A Sanitary Standard for Sensors and Sensor Fittings and Connections, Number 74*".

**Hygienic adapter P in conjunction with VEGAPOINT 31**  
according to "*EHEDG Doc. 2, Doc. 8, Doc. 10 and 3-A Sanitary Standard for Level Sensing Devices for Dry Products, Number 50*".

**Hygienic adapter L in conjunction with VEGAPOINT 11, 21, VEGABAR 29, 39 and VEGAPULS 42, 6X**  
according to "*EHEDG Doc. 2, Doc. 8, Doc. 10 and 3-A Sanitary Standard for Sensors and Sensor Fittings and Connections, Number 74*".

**Hygienic adapter L in conjunction with VEGAPOINT 31**  
according to "*EHEDG Doc. 2, Doc. 8, Doc. 10 and 3-A Sanitary Standard for Level Sensing Devices for Dry Products, Number 50*".

**Hygienic adapter X with VEGAPULS 6X:**  
according to "*EHEDG Doc. 2, Doc. 8, Doc. 10 and 3-A Sanitary Standard for Sensors and Sensor Fittings and Connections, Number 74*".

## 1.2 Scope

The instructions apply to the hygienic adapters L and P in conjunction with the respective sensors. The connections and seals are listed in the manufacturer declarations of the sensors and in this document.

## 2 3-A-/EHEDG-Standards - Meaning and implementation

### Meaning of 3-A

3-A Sanitary Standards Incorporation (SSI) in the USA sets standards for materials, design and manufacturing methods for components used in hygienic processes. The organization also monitors compliance with the hygienic design of these components. Conformity is verified by an independent third party CCE (Certified Conformance Evaluator). In the case of conformity, 3-A SSI issues a symbol license for the 3-A logo.

### Meaning of EHEDG

The European Hygienic Engineering & Design Group (EHEDG) is a consortium of equipment and food manufacturers, food industry suppliers, research institutes and universities. The main objective is to promote safe food by improving hygiene technology and design in all areas of food production (in the latest version). To this end, the EHEDG has drawn up guidelines for the hygienic design of machines and plants as well as the infrastructure of food production.

### Use of instruments according to EHEDG and 3-A

For use in the food sector according to EHEDG or 3-A, special requirements apply compared to standard applications. This applies in particular to:

- Version of the housing (e.g. easy cleaning)
- Configuration of the process fitting (e.g. visibility of possible leakage)
- Seals (e.g. according to FDA and EG1935/2004, or resistant to process and cleaning media)
- Installation position on the vessel (e.g. self-drainage)
- Cleaning and maintenance (e.g. intervals, methods)

The EHEDG and 3-A logos prove that the device version has been tested and certified. The certificate always refers to a combination of sensor and process fitting.

**Process fittings****3 Instrument versions**

Only process fittings listed in chapter "*Manufacturer declaration*" may be used for installations according to 3-A/EHEDG standards.

They meet the hygienic requirements of EHEDG Doc. 2, Doc. 8, Doc. 10 and the 3-A Standard No. 74 and No. 50, including the requirement for self-drainage in the event of a leak in the device seal.

## 4 Mounting

Note the following items for a measuring point according to EHEDG or 3-A standard:

- All parts of the measuring point must comply with 3-A/EHEDG
- The mounting position must allow the self-drainage of the sensor as well as the hole for leakage detection
- The hole for leakage detection in the process fitting must be visible after mounting and possibly point vertically downward
- Welded connections must have a surface roughness  $Ra \leq 0.8 \mu\text{m}$
- Welding sockets must be welded flush with the inside of the vessel. The welding standard AWS D18.3 must be observed for hygienic welding.

### Installation position

In horizontal pipelines, avoid mounting in the upper or lower area of the pipe (see exclusion and limitation in the figure below).

In the upper part of the pipe cavities can form due to air inclusions.

In horizontal pipelines, lateral installation is therefore recommended.

The sensor is optimized for CIP cleaning and does not have to be removed for cleaning.

If the sensor is cleaned manually, do not use tools that damage the active measuring part.

For vertical pipelines, make sure that the sensor is installed as flush as possible.

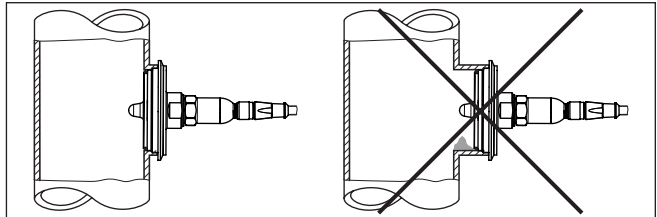

Fig. 1: Mounting in vertical pipeline on the example of VEGAPOINT

### Hygienic adapter

When installing the hygienic adapter, make sure that the hole for leakage detection in the process fitting is at the lowest possible point. See the figure below:

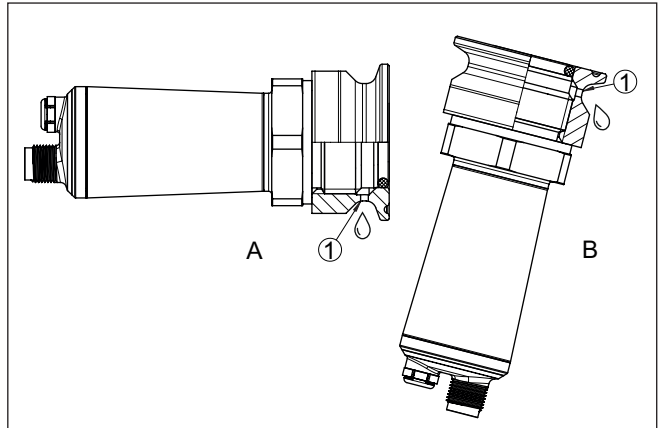

Fig. 2: Alignment of the leakage hole using VEGABAR as an example

1 Leakage hole in the hygienic adapter directed downwards

### Mounting the sensor

For sensor mounting proceed as follows:

1. Avoid contamination when mounting the sensor or the hygienic adapter.  
Therefore, only remove the sensor from its packaging shortly before mounting and, in particular, check the wetted surfaces for damage.
2. Grease the thread of the sensor thinly with a suitable grease (e.g. NSF H1 or according to FDA 21 CFR 178.3570).
3. Mount the hygienic adapter carefully on the intended facility.

For sensor mounting, the manufacturer declarations EHEDG and 3-A of the respective sensors must be observed.

## 5 Maintenance, cleaning, appropriate use

### Maintenance

It is the responsibility of the user to ensure the hygienically safe condition of the sensor during its entire service life.

Leaks in a gasket represent a hygienic risk. To avoid this, they should be checked regularly for damage. Sensor and process adapter form a unit and should be removed together during an inspection. The accessible surface of the sensor must be carefully cleaned.

The user plans the intervals according to the process conditions.

Further information on suitable seals can be found in the manufacturer declarations EHEDG and 3-A of the respective sensors.

### Cleaning

The sensor is optimized for CIP cleaning and does not have to be removed for the cleaning.

When installing in the tank, make sure that the cleaning fitting is positioned so that the connection as well as the sensor can be completely wetted and cleaned.

If a validation without removal is not possible, it is recommended to remove the unit to ensure successful cleaning.

It is the responsibility of the user to ensure the resistance of the sealing material and the sensor against the product and the cleaning process. This is based on resistance lists and the technical data of the respective sensor.

If the area behind the seal becomes dirty, soak this area with a suitable cleaner and then clean it with a suitable cleaning utensil that does not damage the stainless steel.

### Intended use

Salty and acidic foodstuffs such as seasoning concentrates, as well as strongly oxidizing or chlorine-containing cleaning agents, especially at high temperatures and longer exposure times, can also lead to corrosion of stainless steel.

In order to maintain hygienic integrity, regular visual inspection of the parts in contact with the medium and, if necessary, replacement are recommended.

## 6 Manufacturer declaration

### 6.1 3-A

#### Standard 74

We hereby declare that the instrument and process fitting combinations of the following versions of hygienic adapter P and L meet the requirements of 3-A standard 74.

#### Hygienic adapter P with VEGAPOINT 11, 21

In the version: HYGADAPT-P.D[AT, AR, U5, E2, E3, BA, AD, AC, KA, Q6, KW, FR, FS, FC or 7F]

- In conjunction with
  - VEGAPOINT 11 in version: P11(\*\*).[A or D][AC]\*
  - VEGAPOINT 21 in version: P21(\*\*).\*\*\*\*[A or D][AC]\*\*\*

#### Hygienic adapter L with VEGAPOINT 11, 21, VEGABAR 29, 39 and VEGAPULS 42, 6X

In version: HYGADAPT-L.D[AT, AR, E2, E3, AD, AC, Q6, KW, FR, FS or 7F]

- In conjunction with
  - VEGAPOINT 11 in version: P11(\*\*).[A or D][AF]\*
  - VEGAPOINT 21 in version: P21(\*\*).\*\*\*\*[A or D][AF]\*\*\*
  - VEGABAR 29 in version: B29(\*\*).\*\*\*\*[A or D][LX]\*\*\*
  - VEGABAR 39 in version: B39(\*\*).\*\*\*\*[A or D][LX]\*\*\*
  - VEGAPULS 42 in version: PS42(\*\*).\*\*DMaaA7\*\*\*\*
  - VEGAPULS 6X in version: PS6X(\*\*).\*\*\*XMbX

#### Hygienic adapter X with VEGAPULS 6X in version:

HYGADAPT-X-D[CA, CD, CB, CC, CE, DC, DD, EH, LV, L3, LF, LI, LP, LQ, LC, LK, DE, EA, LJ, EC, ED, LW, L7, LZ or VB]

#### Standard 50

We hereby declare that the instrument and process fitting combinations of the following versions of hygienic adapter P and L meet the requirements of 3-A standard 50.

#### Hygienic adapter P with VEGAPOINT 31

In the version: HYGADAPT-P.D[AT, AR, U5, E2, E3, BA, AD, AC, KA, Q6, KW, FR, FS, FC or 7F]

- In conjunction with
  - VEGAPOINT 31 in version: P31(\*\*).\*\*\*\*[A or D][AC]\*\*\*

#### Hygienic adapter L with VEGAPOINT 31

In version: HYGADAPT-L.D[AT, AR, E2, E3, AD, AC, Q6, KW, FR, FS or 7F]

- In conjunction with
  - VEGAPOINT 31 in version: P31(\*\*).\*\*\*\*[A or D][AF]\*\*\*

## 6.2 EHEDG

We hereby declare that the instrument and process fitting combinations of the following versions of hygienic adapter P meet the requirements of EHEDG Doc. 2, Doc. 8, Doc. 10.

### Hygienic adapter P with VEGAPOINT 11, 21, 31

In the version: HYGADAPT-P.D[U5, E2, E3, BA, AD, AC, KA, Q6, KW, FR, FS or 7F]

- In conjunction with
  - VEGAPOINT 11 in version: P11(\*\*).D[AC]\*
  - VEGAPOINT 21 in version: P21(\*\*).\*\*\*\*D[AC]\*\*\*
  - VEGAPOINT 31 in version: P31(\*\*).\*\*\*\*D[AC]\*\*\*

In version: HYGADAPT-P.D[AT or AR] only in combination with Clamp seals Combifit International B.V., The Netherlands

- In conjunction with
  - VEGAPOINT 11 in version: P11(\*\*).D[AC]\*
  - VEGAPOINT 21 in version: P21(\*\*).\*\*\*\*D[AC]\*\*\*
  - VEGAPOINT 31 in version: P31(\*\*).\*\*\*\*D[AC]\*\*\*

### Hygienic adapter X with VEGAPULS 6X in version:

HYGADAPT-X-D[CA, CD, CB, CC, CE, DC, DD, EH, LV, L3, LF, LI, LP, LQ, LC, LK, DE, EA, LJ, EC, ED, LW, L7, LZ or VB]

### Hygienic adapter L with VEGAPOINT 11, 21, 31, 24, VEGABAR 29, 39 and VEGAPULS 42, 6X

In version: HYGADAPT-L.D[AT, AR, E2, E3, AD, AC, Q6, KW, FR, FS or 7F]

- In conjunction with
- VEGAPOINT 11 in version: P11(\*\*).[D][AF]\*
- VEGAPOINT 21 in version: P21(\*\*).\*\*\*\*[D] [AF]\*\*\*
- VEGAPOINT 31 in version: P31(\*\*).\*\*\*\*[D] [AF]\*\*\*
- VEGABAR 29 in version: B29(\*\*).\*\*\*\*[D][LX]\*\*\*
- VEGABAR 39 in version: B39(\*\*).\*\*\*\*[D][LX]\*\*\*
- VEGAPULS 42 in version: PS42(\*\*).\*\*DMaaA7\*\*\*\*
- VEGAPULS 6X in version: PS6X(\*\*).\*\*\*XMBx

**7 3-A certificate**

ISSUE DATE: December 19, 2013

CERTIFICATE AUTHORIZATION NUMBER: 1731



THIS IS TO CERTIFY THAT

VEGA Grieshaber KG

Am Hohenstein 113, Schiltach 77761 , Germany

is hereby authorized to continue to apply the  
3-A Symbol to the models of equipment, conforming to 3-A Sanitary Standards for:

Number 74-07  
74-07 (Sensors and Sensor Fittings and Connections)

set forth below

CIP Models:

VEGAFLEX 83 model FX83(\*\*).\*\*abbC\*\*d\*\*M  
(a = F, H, G, I), (bb = LJ, LB, LC, LD, LA), (d = 8, Z)

VEGASWING 61 model SWING61(\*\*).\*\*bbbd\*\*(\*);  
VEGASWING 63 model SWING63(\*\*).\*\*bbbd\*\*  
(bbb = CAA, CB1, CAD, CFP, CDP, LFP, CEP, CAP, LDP, LCP, SGD, SHP,  
SKA, SK2, SK5, SK6, SLN, SLP, S7P, LAP, RAC, RBC, RCA, RDI, RFP, RDA,  
RDP, RSP, RWP, TAP, TAA, TAY, TNP, CA1, CAN, CDN, CG1, CEN, LAN, TAN,  
CBP, RGP, RCI, CA2, CBN, CBB, CBA, CAB, LHP)  
(d = X, T, G);

Weld-in sockets VEGA Hygienic Connection (code LAN and LAP for SWING61(\*\*). and  
SWING63(\*\*).) Weld-in socket ESTA.LA3\*\*\*

VEGABAR 82 model B/(\*)82.\*\*bbDc\*\*\*\*\*M  
(bb = AV, TD, AT, TE, TF, TV, 6C, PC, 4I, QV, KY, ES, UX, FR, FS, TG, TO, AR, AW, AS, E2, AD, AC,  
AX, KQ, FF, PS, VI, E3, UJ, U5, UQ, SD, SE, UP, VG, EI, EJ, EK, EL, 6H, 4D, UB, TW, G9, 7P, AY, 5F,  
8F, UO, US, UW, G9, 3Z);  
(c = E, G, P, Q, W)

VEGABAR 83 model B/(\*)83.\*\*bbc\*\*\*\*\*M  
(bb = E2, E3, FR, FS, AR, AT, TE, KY, AW, AS, AC, KW, ES, Q4, Q6, FF, LX),  
(c = S, 3, P, E, C, Q, F, N, H, T); where bb = LX, Hygadapt-L is to be used.  
Additional options for VEGABAR only: weld-in socket VEGA Hygienic Connection ES, model codes  
WDSB80.ESM\*G\*\*M and WDSB80.UXM\*G\*\*M;

VEGAPOINT 11 model P11(\*\*).aAC\* and VEGAPOINT 21, model P21(\*\*).\*\*\*\*aAC\*\*\*  
(a = A or D) with adapters:  
HYGADAPT-P.acc (a = A or D), (cc = AT, AR, U5, E2, E3, BA, AD, AC, KA, Q6, KW, FR, FS, 7F).

VEGAPOINT 21 model P21(\*\*).\*\*\*\*aAb\*\*\* (a = A, D), (b = C, N, P, Q, F);

63436-EN-260116

VEGAPOINT 24 model P24(\*\*).\*\*\*aAb\*\*\* where a = A or D and b = N, P, or Q;

VEGAPOINT 11 model P11(\*\*).aAF\*, VEGAPOINT 21 model P21(\*\*).\*\*\*\*aAF\*\*\* and  
VEGAPOINT 24 model P24(\*\*).\*\*\*[A or D]AF\*\*\*  
with adapters HYGADAPT-L.acc (a = A, D), (cc = AR, AS, AT, E2, E3, AD, AC, LV, Q6, KW, FR, FS,  
7F, 7G)

VEGABAR 29, model B29(\*\*).\*\*\*abb\*\*\*\* and  
VEGABAR 39, model B39(\*\*).\*\*\*abb\*\*\*\*  
(a = A or D), (bb = AV, AT, AR, FR, FS, E2, U5);

VEGABAR 29, model B29(\*\*).\*\*\*aLX\*\*\*\* and  
VEGABAR 39, model B39(\*\*).\*\*\*aLX\*\*\*\* (a = A, D);  
with HYGADAPT-L.acc (a = A or D), (cc = AR, AS, AT, E2, E3, AD, AC, LV, Q6, KW, FR, FS, 7F, 7G);

VEGAPULS 6X model PS6X(\*\*).\*\*\*aabXccd\*\*\*\*\*D\*\*;  
where b = T or H and cc = AJ, A6 or A7 and d = 8 or Z and  
where aa = process fitting code: XO for HYGADAPT-X G1 ½ “ and XM for HYGADAPT-L G1” adapters  
or aa = process fitting code for firmly connected adapters:  
CA, CD, CB, CC, CE, DC, DD, LV, EH, L3, LF, LI, LP, LC, LK, EC, ED, LW, L7, LZ, CG, LD, VA, VB,  
AR, E2, E3, AC, Q6, KW, FR or 7F;

Adapters for VEGAPULS 6X:

HYGADAPT-L.Dcc (cc = AR, AS, AT, E2, E3, AD, AC, LV, Q6, KW, FR, 7F, 7G);  
HYGADAPT-X.Dcc (cc = CA, CD, CB, CC, CE, DC, DD, EH, L3, LF, LI, LP, LC, LK, EC, ED, LW, L7,  
LZ or VB);

VEGAPULS 42 model PS42(\*\*).\*\*DMaaA7\*\*\*\*;  
where aa = XX (no adapter) or HYGADAPT-L.Dcc (cc = AR, AS, AT, FS, FR, E2, E3, AC, AD, LV, KW,  
Q6, 7F, 7G); A7 = material / seal / process temperature

VALID THROUGH: **December 31, 2026**

The issuance of this authorization for the use of the 3-A Symbol is based upon the voluntary certification, by the applicant for it, that the equipment listed above complies fully with the 3-A Sanitary Standard(s) designated. Legal responsibility for compliance is solely that of the holder of this Certificate of Authorization, and 3-A Sanitary Standards, Inc. does not warrant that the holder of an authorization at all times complies with the provisions of the said 3-A Sanitary Standards. This in no way affects the responsibility of 3-A Sanitary Standards, Inc. to take appropriate action in such cases in which evidence of nonconformance has been established.

NEXT TPV INSPECTION/REPORT DUE: **October 2028**

ISSUE DATE: June 04, 2003

CERTIFICATE AUTHORIZATION NUMBER: 1260



THIS IS TO CERTIFY THAT

VEGA Americas, Inc.

3877 Mason Research Pkwy, Mason, OH 45036

is hereby authorized to continue to apply the  
3-A Symbol to the models of equipment, conforming to 3-A Sanitary Standards for:

Number 74-07  
74-07 (Sensors and Sensor Fittings and Connections)

set forth below

CIP Model(s):

VEGAFLEX 83 model FX83(\*\*).\*\*abbC\*\*d\*\*M  
(a = F, H, G, I), (bb = LJ, LB, LC, LD, LA), (d = 8, Z)

VEGAPULS 63 model PS63(\*\*).\*\*Nbb\*d\*\*X  
(bb = CA, CB, CC, CD, DC, DD, LC, EC, LK), (d = 8, Z)

VEGAPULS 64 model PS64(\*\*).\*\*abc\*\*d\*\*\*M  
(a = H, I), (bb = CA, CB, CC, CD, DC, DD, LC, EC, LK), (c = I, J), (d = 8, Z)

VEGASWING 61 model SWING61(\*\*).\*\*bbbd\*\*(\*);  
VEGASWING 63 model SWING63(\*\*).\*\*bbbd\*\*  
(bbb = CAA, CB1, CAD, CFP, CDP, LFP, CEP, CAP, LDP, LCP, SGD, SHP,  
SKA, SK2, SK5, SK6, SLN, SLP, S7P, LAP, RAC, RBC, RCA, RDI, RFP, RDA,  
RDP, RSP, RWP, TAP, TAA, TAY, TNP, CA1, CAN, CDN, CG1, CEN, LAN, TAN,  
CBP, RGP, RCI, CA2, CBN, CBB, CBA, CAB, LHP)  
(d = X, T, G);  
Weld-in sockets VEGA Hygienic Connection (code LAN and LAP for SWING61(\*\*). and  
SWING63(\*\*).) Weld-in socket ESTA.LA3\*\*\*;

VEGABAR 82 model B/(\*)82.\*\*bbc\*\*\*\*\*M  
(bb = AV, TD, AT, TE, TF, TV, 6C, PC, 4I, QV, KY, ES, UX, FR, FS, TG, TO, AR, AW, AS, E2, AD, AC,  
AX, KQ, ES, FF, PS, VI, E3, UJ, U5, UQ, SD, SE, UP, VG, EI, EJ, EK, EL, 6H, 4D, UB, TW, G9, 7P,  
AY, 5F, 8F, UO, US, UW, G9, 3Z); (c = D, F, G, P, Q, V, W);

VEGABAR 83 model B/(\*)83.\*\*bbc\*\*\*\*\*M  
(bb = E2, E3, FR, FS, AR, AT, TE, KY, AW, AS, AC, KW, ES, Q4, Q6, FF, LX),  
(c = S, 3, P, E, C, Q, F, N, H, T)

Additional options for VEGABAR only: weld-in socket VEGA Hygienic Connection ES, model codes  
WDSB80.ESM\*G\*\*M and WDSB80.UXM\*G\*\*M;

VEGAPOINT 11 model P11(\*\*).aAC\* and VEGAPOINT 21, model P21(\*\*).\*\*\*\*aAC\*\*

63436-EN-260116

(a = A or D) with adapters:

HYGADAPT-P.acc (a = A or D), (cc = AT, AR, U5, E2, E3, BA, AD, AC, KA, Q6, KW, FR, FS, 7F);

VEGAPOINT 21 model P21(\*\*).\*\*\*aAb\*\*\* (a = A, D), (b = C, N, P, Q, F);

VEGAPOINT 24 model P24(\*\*).\*\*\*aAb\*\*\* where a = A or D and b = N, P, or Q;

VEGAPOINT 11 model P11(\*\*).aAF\*, VEGAPOINT 21 model P21(\*\*).\*\*\*aAF\*\*\* and

VEGAPOINT 24 model P24(\*\*).\*\*\*[A or D]AF\*\*\*

with adapters HYGADAPT-L.acc (a = A, D), (cc = AT, AR, E2, E3, AD, AC, Q6, KW, FR, FS, 7F, 7G);

VEGABAR 29, model B29(\*\*).\*\*\*abb\*\*\*\* and

VEGABAR 39, model B39(\*\*).\*\*\*abb\*\*\*\*

(a = A or D), (bb = AV, AT, AR, FR, FS, E2, U5);

VEGABAR 29, model B29(\*\*).\*\*\*aLX\*\*\*\* and

VEGABAR 39, model B39(\*\*).\*\*\*aLX\*\*\*\* (a = A, D);

with HYGADAPT-L.acc (a = A or D), (cc = AT, AR, E2, E3, AD, AC, Q6, KW, FR, FS, 7F).

VALID THROUGH: **December 31, 2026**

The issuance of this authorization for the use of the 3-A Symbol is based upon the voluntary certification, by the applicant for it, that the equipment listed above complies fully with the 3-A Sanitary Standard(s) designated. Legal responsibility for compliance is solely that of the holder of this Certificate of Authorization, and 3-A Sanitary Standards, Inc. does not warrant that the holder of an authorization at all times complies with the provisions of the said 3-A Sanitary Standards. This in no way affects the responsibility of 3-A Sanitary Standards, Inc. to take appropriate action in such cases in which evidence of nonconformance has been established.

NEXT TPV INSPECTION/REPORT DUE: **August 2027**

ISSUE DATE: February 11, 2021

CERTIFICATE AUTHORIZATION NUMBER: 3808



THIS IS TO CERTIFY THAT

VEGA Grieshaber KG

Am Hohenstein 113, Schiltach 77761 , Germany

is hereby authorized to continue to apply the  
3-A Symbol to the models of equipment, conforming to 3-A Sanitary Standards for:

Number 50-02

50-02 (Level Sensing Devices for Dry Products)

set forth below

CIP models:

VEGAPOINT 31 model P31(\*\*).\*\*\*aAC\*\*\* (a = A or D) with adapters:

HYGADAPT-P.acc (a = A or D), (cc = AT, AR, U5, E2, E3, BA, AD, AC, KA, Q6, KW, FR, FS, 7F);

VEGAPOINT 31 model P31(\*\*).\*\*\*aAb\*\*\* (a = A, D), (b = C, N, P, Q, F);

VEGAPOINT 31 model P31(\*\*).\*\*\*aAF\*\*\* with adapters:

HYGADAPT-L.acc (a = A, D), (cc = AT, AR, E2, E3, AD, AC, Q6, KW, FR, FS, 7F);

VEGAVIB 61 model VB61(\*).\*\*a[bb]\*\*\*X ;

VEGAVIB 63 model VB63(\*).\*\*a[bb]\*\*\*X

with version / process temperature a = A, B, C

and process connections bb = RD, C2, CV, CQ, CM, LV;

Weld-in socket VEGA Hygienic Connection ESTA.LA3\*\*\*

VALID THROUGH: **December 31, 2026**

The issuance of this authorization for the use of the 3-A Symbol is based upon the voluntary certification, by the applicant for it, that the equipment listed above complies fully with the 3-A Sanitary Standard(s) designated. Legal responsibility for compliance is solely that of the holder of this Certificate of Authorization, and 3-A Sanitary Standards, Inc. does not warrant that the holder of an authorization at all times complies with the provisions of the said 3-A Sanitary Standards. This in no way affects the responsibility of 3-A Sanitary Standards, Inc. to take appropriate action in such cases in which evidence of nonconformance has been established.

NEXT TPV INSPECTION/REPORT DUE: **January 2026**

# 8 EHEDG certificate

CERTIFICATE OF COMPLIANCE



EL Class I

Date of issue: 22 May 2025

Valid until: 31 December 2026

*EHEDG hereby declares that the product*

***level switch VEGAPOINT, type 11, 21 and 31 with PEEK cap and G1/2" process connection HYGADAPT-P.Dxx or G1" process adapter HYGADAPT-L.Dxx with EPDM O-ring***

*from*

*VEGA Grieshaber KG, Am Hohenstein 113, 77761 Schiltach, Germany*

*has/have been evaluated for compliance and meets/meet the current criteria for Hygienic Equipment Design of closed and open process applications of the EHEDG*

**Certificate No. EHEDG-C2500022**

Signed Hein Timmerman President EHEDG

Signed Karlijn Faber EHEDG Certification Officer

EHEDG  
Karspeldreef 8  
1101 CJ Amsterdam  
Netherlands

©EHEDG



European Hygienic Engineering & Design Group

### APPENDIX 3 EHEDG Certification – Equipment Evaluation Form

Design Evaluation Date: 16.12.2024  
EHEDG File Number: EHEDG-R2500021  
Certification Type: EL CLASS I

Applicant: VEGA Grieshaber KG

Equipment: level switch VEGAPOINT, type 11, 21 and 31 with PEEK cap and G1/2" process connection HYGADAPT-P.Dxx or G1" process adapter HYGADAPT-L.Dxx with EPDM O-ring

Other essential identification:

**Evaluated by:**

Name: Dr. Jürgen Hofmann

Date, Signature: 12.05.2025

**Approved by:**

Name: Dr. Nicolas Rossi

Date, Signature: 15/05/2025

The use of the EHEDG Certification logo is justified based on the results of the design evaluation, inspection, and testing (as applicable) of the equipment for compliance with the current EHEDG Hygienic Design Criteria (HDC):

Criteria	Certification for use in Closed Processes
<input type="checkbox"/>	The equipment complies with all applicable HDC in the Guidelines.
<input checked="" type="checkbox"/>	Evidence for compliance required and provided by in-place cleanability test method according to EHEDG Doc. 2.
<input type="checkbox"/>	Evidence for compliance required and provided by in-place cleanability test method according to EHEDG Doc. 2, in-place sterilisability test method according to EHEDG Doc. 5, and bacteria tightness test according to EHEDG Doc. 7 for EL ASEPTIC Certification.
Criteria	Certification for use in Open Processes
<input type="checkbox"/>	The equipment complies with all applicable HDC in the Guidelines.
<input type="checkbox"/>	Evidence for compliance required and provided by OPC cleanability test method according to EHEDG Doc. 57.

*The original of this form will be kept by EHEDG together with the application, the evaluation report, the evidence provided and any other relevant documentation, as listed on the back.*



### APPENDIX 3

No.	Description
1.	EHEDG Certificate of Compliance
2.	Contract to use the EHEDG Certification Logo for equipment
3.	Appendix 1: Equipment intended for cleaning-in-place with liquids without dismantling
4.	Appendix 2: conditions for use of the EHEDG Certification Logo
5.	Appendix 3: Equipment evaluation form
6.	Evaluation report of the design of the level switch VEGAPOINT, type 11, 21 and 31 with PEEK cap and G1/2" process connection HYGADAPT-P.Dxx or G1" process adapter HYGADAPT-L.Dxx with EPDM O-ring, no. 808TUM2025
7.	Drawings of the level switch VEGAPOINT, type 11, 21 and 31 with PEEK cap and G1/2" process connection HYGADAPT-P.Dxx or G1" process adapter HYGADAPT-L.Dxx with EPDM O-ring, drawing nos. GE4153, GE4028, 1087403, ZT57657,1040693; original stamped
8.	Test reports of the in-place cleanability test method according to Doc. 2, Test nos. 666/22.02.2019 and 808/14.02.2025.
9.	Cleaning and Installation manual no. 62398 supplied by the manufacturer
10.	Example of EHEDG Certified Logo Type EL CLASS I



Printing date:

**VEGA**

All statements concerning scope of delivery, application, practical use and operating conditions of the sensors and processing systems correspond to the information available at the time of printing.

Subject to change without prior notice

© VEGA Grieshaber KG, Schiltach/Germany 2026

63436-EN-260116

VEGA Grieshaber KG  
Am Hohenstein 113  
77761 Schiltach  
Germany

Phone +49 7836 50-0  
E-mail: [info.de@vega.com](mailto:info.de@vega.com)  
[www.vega.com](http://www.vega.com)