

Safety instructions

VEGATRENN 141, 142

Installation in Zone 2
with output intrinsic safety "i"



Document ID: 64575



VEGA

Contents

1	Area of applicability.....	3
2	Device configuration/-properties	3
3	General information.....	3
4	Application area, use in gas and dust atmospheres.....	3
5	Special operating conditions.....	3
6	Safe operating mode	5
7	Important information for mounting and maintenance.....	5
8	Electrostatic charging (ESD).....	6
9	Electrical data.....	6
10	Mechanical data.....	7
11	Thermal data	8
12	Installation.....	8

Supplementary documentation:

- Operating Instructions VEGATRENN 141, 142
- Certificate of Conformity IECEx ULD 20.0018X (Document ID: 64576)

Editing status: 2021-01-28

1 Area of applicability

These safety instructions apply to the devices:

- VEGATRENN 141
- VEGATRENN 142

In accordance with the Certificate of Conformity IECEx ULD 20.0018X, as associated equipment for installation in Zone 2 (certificate number on type plate) and for all devices with safety instruction 64575.

The classification as well as the respective standards are stated in the above certificates:

Type of protection marking:

- Ex ec [ja Ga] IIC T4 Gc
- Ex ec [ja IIIC Da] IIC T4 Gc
- Ex ec [ja I Ma] IIC T4 Gc

2 Device configuration/-properties

The detailed device configurations can be retrieved using the serial number search on our homepage.

Move to "www.vega.com" and enter in the search field the serial number of your instrument.

Alternatively, you can find all via your smartphone:

- Download the VEGA Tools app from the "*Apple App Store*", "*Google Play Store*" or "*Baidu Store*"
- Scan the DataMatrix code on the type label of the instrument or
- Enter the serial number manually in the app

3 General information

The single and double channel separators VEGATRENN 141, 142 are used for galvanic separation, intrinsically safe power supply as well as signal transmission of Ex approved 4 ... 20 mA sensors in hazardous areas.

The separators are ideal in conjunction with signal conditioning instruments, e.g. PLC, having no own Ex-approval and have to allow bidirectional HART transmission.

The instruments are used for separation of intrinsically safe and non-intrinsically safe circuits and intrinsically safe supply of field sensors.

The VEGATRENN 141, 142 are active separators, detecting the intrinsically safe current of a sensor in Ex area and making it available to a non-intrinsically safe, passive output.

The operating instructions as well as the installation regulations or standards that apply for explosion protection of electrical systems must generally be observed.

The installation of explosion-protected systems must always be carried out by qualified personnel.

4 Application area, use in gas and dust atmospheres

EPL Gc instrument

The VEGATRENN 141, 142 may be installed and operated inside of hazardous areas as associated equipment for installation in zone 2.

5 Special operating conditions

The following overview is listing all special properties of VEGATRENN 141, 142, which make a labelling with the symbol "X" behind the certificate number necessary.

Ambient temperature

You can find the details in chapter " *Thermal data*" of these safety instructions.

The installer must ensure that the rated ambient temperature range of the device is not exceeded when it is installed in a housing together with other devices and that adequate separation is provided around the device.

Zone 2 applications

The device must be installed in a protective housing or a switching cabinet with IP54 according to IEC 60079-0.

The device may only be used in an area with a minimum pollution level of 2 or better, as defined in IEC 60664-1.

Mounting options

The VEGATRENN 141, 142 must be mounted horizontally or vertically on a wall mounting rail (DIN rail).

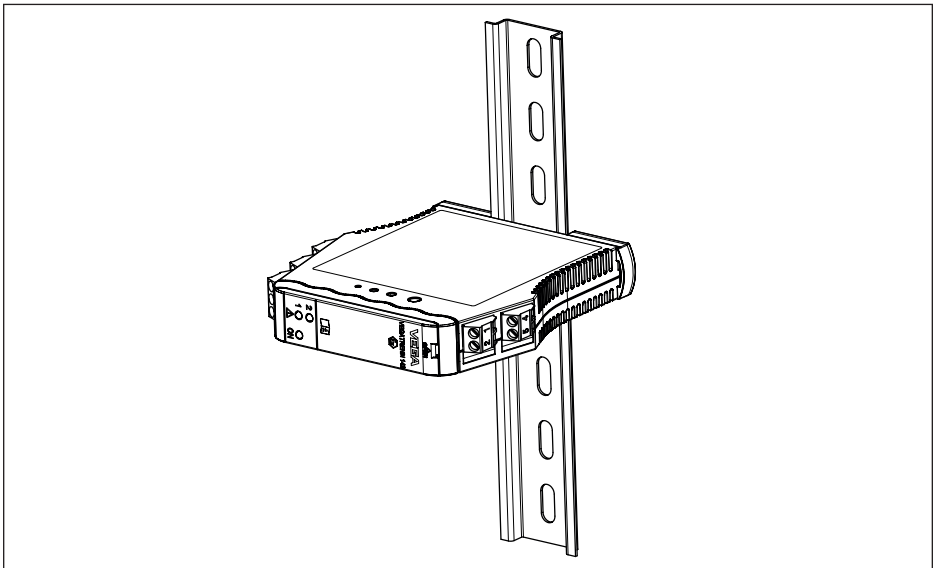
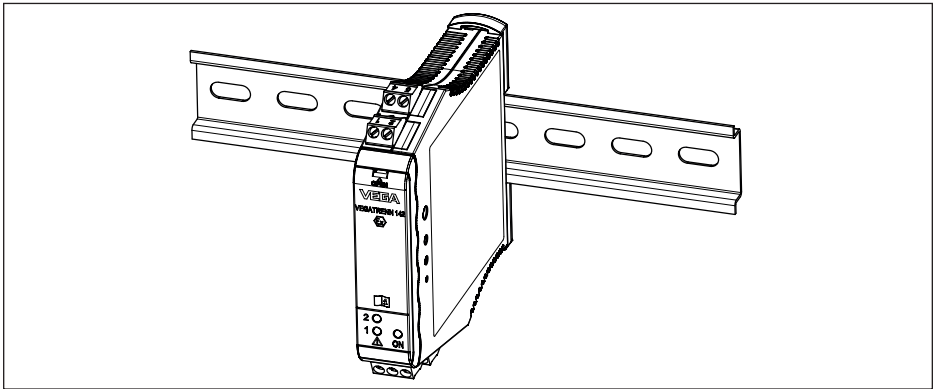

6 Safe operating mode

General operating conditions

- Do not operate the instrument outside the electrical, thermal and mechanical specifications of the manufacturer

Connection conditions

- The connection cable of VEGATRENN 141, 142 has to be wired fix and in such a way that damages can be excluded
- If the temperature at the entry parts exceeds 70 °C, temperature-resistant connection cables must be used

7 Important information for mounting and maintenance

General instructions

The following requirements must be fulfilled for mounting, electrical installation, setup and maintenance of the instrument:

- The staff must be qualified according the respective tasks
- The staff must be trained in explosion protection
- The staff must be familiar with the respectively valid regulations, e.g. planning and installation acc. to IEC 60079-14
- Make sure when working on the instrument (mounting, installation, maintenance) that there is no explosive atmosphere present, the supply circuits should be voltage-free, if possible.
- The instrument has to be mounted according to the manufacturer specifications, the Certificate of Conformity and the valid regulations and standards
- Modifications on the instrument can influence the explosion protection and hence the safety, therefore repairs are not permitted to be conducted by the end user
- Modifications must only be carried out by employees authorized by VEGA company
- Use only approved spare parts
- Components for installation and connection not included in the approval documents are only permitted if these correspond technically to the latest standard mentioned on the cover sheet. They must be suitable for the application conditions and have a separate certificate. The special conditions of the components must be noted and if necessary, the components must be integrated in the type test. This applies also to the components already mentioned in the technical description.

Mounting

Keep in mind for instrument mounting

- Mechanical damage on the instrument must be avoided
- Mechanical friction must be avoided

Maintenance

To ensure the functionality of the device, periodic visual inspection is recommended for:

- Secure mounting
- No mechanical damages or corrosion
- Worn or otherwise damaged cables
- No loose connections of the line connections, equipotential bonding connections
- Correct and clearly marked cable connections

Intrinsic safety "i"

- Observe the valid regulations for the interconnection of intrinsically safe circuits.
- The instrument is only suitable for connection to certified, intrinsically safe instruments

- If the intrinsically safe circuit is lead into dust-explosive areas of zone 20 or 21, please make sure that the instruments which are connected to these circuits meet the requirements of EPL Da or EPL Db and are certified respectively

8 Electrostatic charging (ESD)

In case of instrument versions with electrostatically chargeable plastic parts, the danger of electrostatic charging and discharging must be taken into account!

The following parts can charge and discharge:

- Lacquered housing version or alternative special lacquering
- Plastic housing, plastic housing parts
- Metal housing with inspection window
- Plastic process fittings
- Plastic-coated process fittings and/or plastic-coated sensors
- Connection cable for separate versions
- Type label
- Isolated metallic labels (measuring point identification plate)

Take note in case of danger of electrostatic charges:

- Avoid friction on the surfaces
- Do not dry clean the surfaces

The instruments must be mounted/installed in such a way that the following can be ruled out:

- electrostatic charges during operation, maintenance and cleaning.
- process-related electrostatic charges, e.g. by measuring media flowing past

The warning label indicates danger:

WARNING - POTENTIAL ELECTROSTATIC CHARGING HAZARD - SEE INSTRUCTIONS

9 Electrical data

VEGATRENN 141, 142

Non-intrinsically safe circuit

Supply circuit:	VEGATRENN 141
Terminals 16[+, L], 17[-, N]	U = 24 ... 65 V DC (-15 ... +10 %) P = 3 W U = 24 ... 230 V AC (-15 ... +10 %), 50/60 Hz P = 15 VA U _m = 253 V AC
Supply circuit:	VEGATRENN 142
Terminals 16[+, L], 17[-, N]	U = 24 ... 31 V DC (-15 ... +10 %) P = 5 W U _m = 253 V AC

Current output circuit:	
$I_{out 1}$, terminals 10, 11, 12[-] In addition only VEGATRENN 142: $I_{out 2}$, terminals 13, 14, 15[-]	$I = 4 \dots 20 \text{ mA/HART aktiv}$ $U \leq 16.5 \text{ V DC}$ Load $\leq 600 \text{ Ohm}$ (without integrated HART resistor) $U_m = 253 \text{ V AC}$

Intrinsically safe circuit

Supply and signal circuit:	
4 ... 20 mA sensor 1: Terminals 1[+], 2[-] In addition only VEGATRENN 142: 4 ... 20 mA sensor 2: Terminals 4[+], 5[-]	In type of protection intrinsic safety Ex ia IIC, IIB/IIC, I. For connection to a certified, intrinsically safe circuit. $U_o \leq 26.3 \text{ V DC}$ $I_o \leq 100 \text{ mA}$ $P_o \leq 658 \text{ mW}$ Characteristics: linear $C_i = 1.2 \text{ nF}$ L_i negligibly small The maximum values given in the table can be used as concentrated capacitances and concentrated inductances. The values for IIC and IIB are also permissible for dust explosive areas.

Ex ia	IIC		IIB, IIC		IIA	I
Permissible external inductance L_o	0.2 mH	1 mH	0.2 mH	2 mH	10 mH	5 mH
Permissible external capacitance C_o	95.8 nF	54.8 nF	618.8 nF	328.8 nF	508.8 nF	708.8 nF
Permissible outer L_o/R_o -ratio	-	-	216 $\mu\text{H}/\text{Ohm}$	216 $\mu\text{H}/\text{Ohm}$	433 $\mu\text{H}/\text{Ohm}$	710 $\mu\text{H}/\text{Ohm}$

The intrinsically safe circuits of VEGATRENN 141, 142 are galvanically separated from ground.

The intrinsically safe circuits of the VEGATRENN 141, 142 are reliably separated from the non-intrinsically safe circuit up to a peak value of 375 V.

The maximum voltage on the non-intrinsically safe circuits must not exceed 253 Vrms in the event of a fault.

10 Mechanical data

The following mechanical data are valid for all housing and electronics versions.

Mechanical data	
Protection (IEC/EN 60529)	IP20
Connection cross-section:	0.25 ... 2.5 mm ²
Stripping length	7 mm
Overvoltage category	II
Pollution degree	2

11 Thermal data

Permissible ambient temperatures

Permissible ambient temperature at the installation location of an instrument	Ambient temperature (Ta)
as associated apparatus for installation in zone 2	-20 ... +60 °C (-4 ... +140 °F)

12 Installation

The VEGATRENN 141, 142 as associated equipment for installation in zone 2 can be mounted and operated within hazardous areas of zone 2.

For zone 2: The equipment must be mounted in a housing that has been tested according to IEC 60079-0 and meets the requirements of protection class IP54.

The device may then only be installed in locations that offer adequate protection against the ingress of solid foreign objects or liquids.

The suitability of the housing is subject to the approval of the local authorities responsible at the time of installation.

The device may only be used in an area with a pollution degree of 2 or better.

With zone 2 applications, the torque of the terminals should be between 0.4 Nm and 0.5 Nm.

The wire cross-section can be used between 0.25 mm² and 2.5 mm².

The housing used must be labelled with the following warning:

WARNING – EXPLOSION HAZARD: DO NOT CONNECT OR DISCONNECT WHEN ENERGIZED

If the intrinsically safe circuit is led into dust-explosive areas of zone 20 or 21, please make sure that the instruments connected to these circuits meet the requirements of the device protection level (EPL) Da or Db and are certified respectively.

If the intrinsically safe circuit is led into firedamp endangered areas of group I category M1 (EPL Ma instruments) or M2 (EPL Mb instruments), please make sure that the instruments connected to these circuits meet the requirements of the device protection level (EPL) Ma or Mb and are certified respectively.



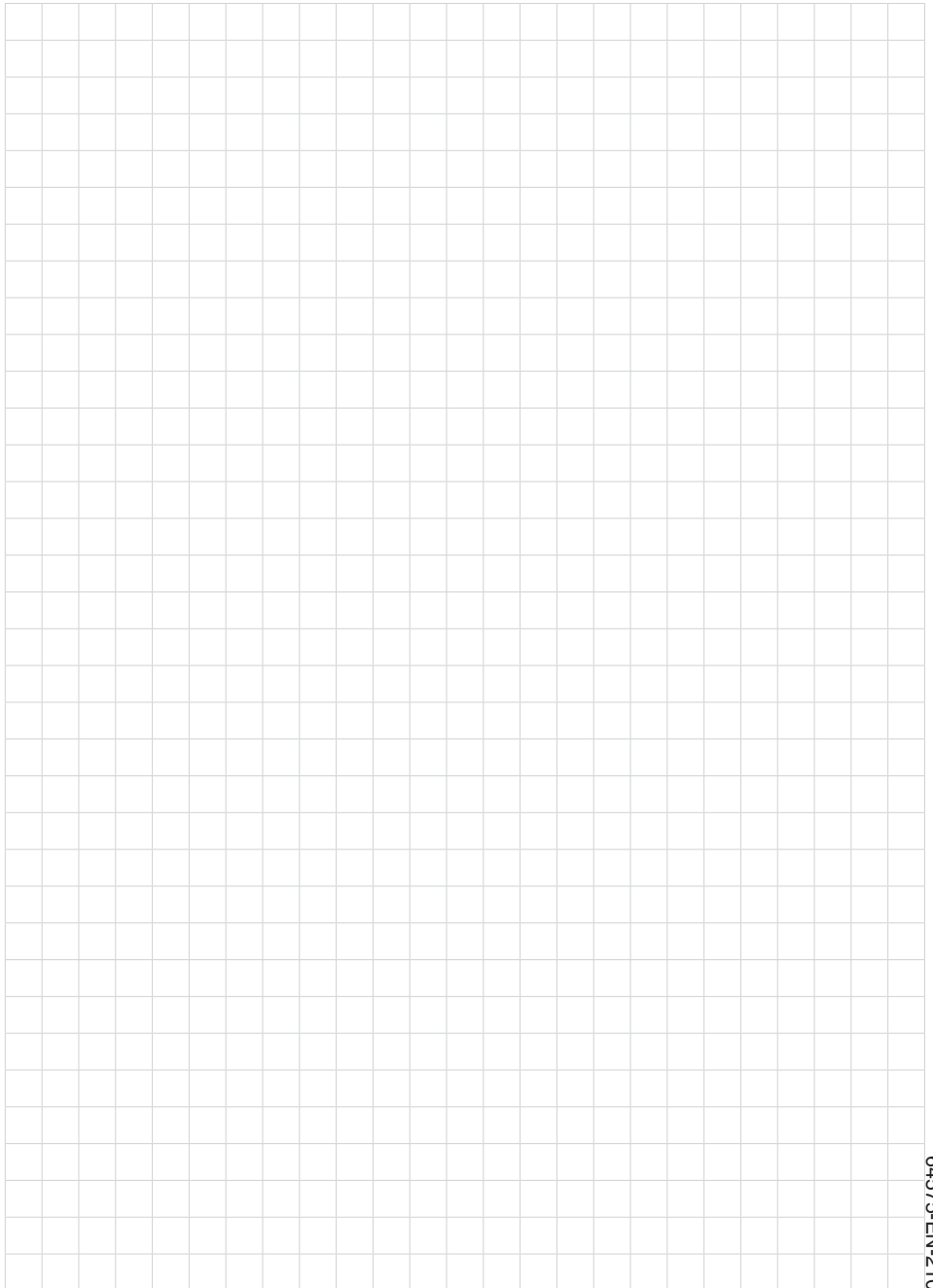



Printing date:

VEGA

All statements concerning scope of delivery, application, practical use and operating conditions of the sensors and processing systems correspond to the information available at the time of printing.

Subject to change without prior notice

© VEGA Grieshaber KG, Schiltach/Germany 2021

64575-EN-210223

VEGA Grieshaber KG
Am Hohenstein 113
77761 Schiltach
Germany

Phone +49 7836 50-0
E-mail: info.de@vega.com
www.vega.com