

Operating Instructions

Radar sensor for continuous level measurement

VEGAPULS 42

Three-wire: IO-Link, transistor, 4 ... 20 mA (active)



Document ID: 1016153



VEGA

Contents

1	About this document	4
1.1	Function	4
1.2	Target group	4
1.3	Symbols used.....	4
2	For your safety	5
2.1	Authorised personnel	5
2.2	Intended use	5
2.3	Warning about incorrect use.....	5
2.4	General safety instructions	5
2.5	Mode of operation - Radar signal	6
2.6	Installation and operation in the USA and Canada	6
2.7	Safety instructions for Ex areas	6
3	Product description	7
3.1	Configuration.....	7
3.2	Principle of operation.....	8
3.3	Adjustment	9
3.4	Packaging, transport and storage.....	9
3.5	Accessories.....	10
4	Mounting	11
4.1	General instructions	11
4.2	Mounting instructions	12
5	Connecting to power supply	18
5.1	Preparing the connection	18
5.2	Connection procedure.....	18
5.3	Wiring plan	19
5.4	Switch-on phase.....	19
6	Access protection	20
6.1	Bluetooth radio interface	20
6.2	Protection of the parameterization.....	20
6.3	Storing the codes in myVEGA	21
7	Set up with the integrated display and adjustment unit	22
7.1	Adjustment system	22
7.2	Measured value and menu item display	23
7.3	Parameter adjustment	24
8	Setup with smartphone/tablet (Bluetooth)	36
8.1	Preparations.....	36
8.2	Connecting.....	36
8.3	Parameter adjustment	37
9	Setup with PC/notebook (Bluetooth)	38
9.1	Preparations.....	38
9.2	Connecting.....	38
9.3	Parameter adjustment	39
10	Menu overview	40
10.1	Functions and adjustment possibilities	40
10.2	Explanation special parameters	43

11	Diagnostics and servicing	45
11.1	Maintenance	45
11.2	Rectify faults	45
11.3	Diagnosis, fault messages	46
11.4	Status messages according to NE 107	47
11.5	Treatment of measurement errors	49
11.6	Software update	51
11.7	How to proceed if a repair is necessary	51
12	Dismount.....	53
12.1	Dismounting steps.....	53
12.2	Disposal	53
13	Certificates and approvals	54
13.1	Radio licenses.....	54
13.2	Food and pharmaceutical certificates.....	54
13.3	Conformity.....	54
13.4	NAMUR recommendations	54
13.5	Environment management system	54
14	Supplement	56
14.1	Technical data	56
14.2	IO-Link	62
14.3	Dimensions	71
14.4	Industrial property rights.....	73
14.5	Licensing information for open source software	73
14.6	Trademark.....	73

1 About this document

1.1 Function

This instruction provides all the information you need for mounting, connection and setup as well as important instructions for maintenance, fault rectification, safety and the exchange of parts. Please read this information before putting the instrument into operation and keep this manual accessible in the immediate vicinity of the device.

1.2 Target group

This instruction manual is directed to trained personnel. The contents of this manual must be made available to the qualified personnel and implemented.

1.3 Symbols used



Document ID

This symbol on the front page of this instruction refers to the Document ID. By entering the Document ID on www.vega.com you will reach the document download.



Information, note, tip: This symbol indicates helpful additional information and tips for successful work.



Note: This symbol indicates notes to prevent failures, malfunctions, damage to devices or plants.



Caution: Non-observance of the information marked with this symbol may result in personal injury.



Warning: Non-observance of the information marked with this symbol may result in serious or fatal personal injury.



Danger: Non-observance of the information marked with this symbol results in serious or fatal personal injury.



Ex applications

This symbol indicates special instructions for Ex applications.



List

The dot set in front indicates a list with no implied sequence.



Sequence of actions

Numbers set in front indicate successive steps in a procedure.



Disposal

This symbol indicates special instructions for disposal.

2 For your safety

2.1 Authorised personnel

All operations described in this documentation must be carried out only by trained and authorized personnel.

During work on and with the device, the required personal protective equipment must always be worn.

2.2 Intended use

VEGAPULS 42 is a sensor for continuous level measurement.

You can find detailed information about the area of application in chapter "*Product description*".

Operational reliability is ensured only if the instrument is properly used according to the specifications in this document as well as possible supplementary instructions.

2.3 Warning about incorrect use

Inappropriate or incorrect use of this product can give rise to application-specific hazards, e.g. vessel overfill through incorrect mounting or adjustment. Damage to property and persons or environmental contamination can result. Also, the protective characteristics of the instrument can be impaired.

2.4 General safety instructions

This is a state-of-the-art instrument complying with all prevailing regulations and directives. The instrument must only be operated in a technically flawless and reliable condition. The operating company is responsible for the trouble-free operation of the instrument. When measuring aggressive or corrosive media that can cause a dangerous situation if the instrument malfunctions, the operating company has to implement suitable measures to make sure the instrument is functioning properly.

The safety instructions in this instructions manual, the national installation standards as well as the valid safety regulations and accident prevention rules must be observed.

For safety and warranty reasons, any invasive work on the device beyond that described in this instructions manual may be carried out only by personnel authorised by us. Arbitrary conversions or modifications are explicitly forbidden. For safety reasons, only the accessory specified by us must be used.

To avoid any danger, the safety approval markings and safety tips on the device must also be observed.

The low transmitting power of the radar sensor is far below the internationally approved limits. No health impairments are to be expected with intended use. The band range of the measuring frequency can be found in chapter "*Technical data*".

2.5 Mode of operation - Radar signal

Country or region specific settings for the radar signals are determined via the mode. The operating mode must be set in the operating menu via the respective operating tool at the beginning of the setup.



Caution:

Operating the device without selecting the relevant mode constitutes a violation of the regulations of the radio approvals of the respective country or region.

2.6 Installation and operation in the USA and Canada

This information is only valid for USA and Canada. Hence the following text is only available in the English language.

Installations in the US shall comply with the relevant requirements of the National Electrical Code (NEC - NFPA 70) (USA).

Installations in Canada shall comply with the relevant requirements of the Canadian Electrical Code (CEC Part I) (Canada).

2.7 Safety instructions for Ex areas

For applications in hazardous areas (Ex), only devices with corresponding Ex approval may be used. Observe the Ex-specific safety instructions. These are an integral part of the device documentation and are enclosed with every device with Ex approval.

3 Product description

3.1 Configuration

Scope of delivery

The scope of delivery encompasses:

- Radar sensor
- Information sheet "*Documents and software*" with:
 - Instrument serial number
 - QR code with link for direct scanning
- Information sheet "*PINs and Codes*" (with Bluetooth versions) with:
 - Bluetooth access code
- Information sheet "*Access protection*" (with Bluetooth versions) with:
 - Bluetooth access code
 - Emergency Bluetooth unlock code
 - Emergency device code

The further scope of delivery encompasses:

- Documentation
 - Ex-specific "*Safety instructions*" (with Ex versions)
 - Radio licenses
 - If necessary, further certificates



Information:

Optional instrument features are also described in this instructions. The respective scope of delivery results from the order specification.

Constituent parts

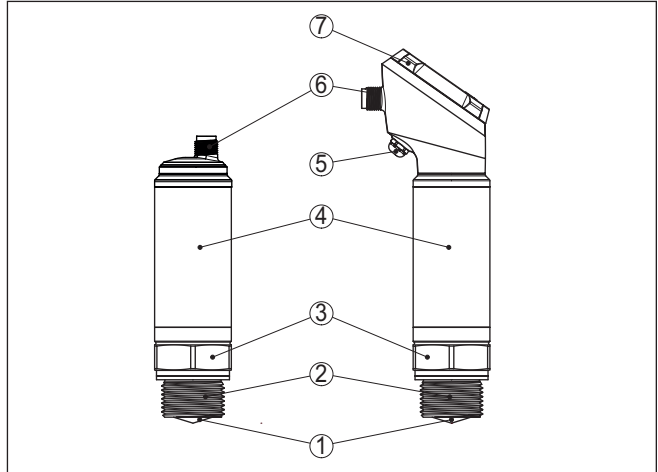

Fig. 1: Components of VEGAPULS 42

- 1 Radar antenna
- 2 Process fitting
- 3 Process seal
- 4 Electronics housing
- 5 Ventilation/pressure compensation
- 6 Round plug connector
- 7 Display and adjustment unit

Type label

The type label contains the most important data for identification and use of the instrument:

- Instrument type
- Information about approvals
- Configuration information
- Technical data
- Serial number of the instrument
- QR code for device identification
- Numerical code for Bluetooth access (optional)
- Manufacturer information

Documents and software

To find order data, documents or software related to your device, you have the following options:

- Move to "www.vega.com" and enter in the search field the serial number of your instrument.
- Scan the QR code on the type label.
- Open the VEGA Tools app and enter the serial number under "**Documentation**".

3.2 Principle of operation

Application area

VEGAPULS 42 is a radar sensor for non-contact, continuous level measurement of liquids and bulk solids.

Functional principle The instrument emits a frequency-modulated continuous radar signal (FMCW) through its antenna. The emitted signal is reflected by the medium and received by the antenna as an echo with modified frequency. The frequency change is proportional to the distance and is converted into the level.

3.3 Adjustment

IO-Link The sensor must be connected to the IO-Link control via the IO-Link master. The associated IODD (IO Device Description) is required for operation and can be found using IODDfinder. Alternatively, a PLC can communicate directly with the sensor using the device-specific IO-Link parameters.

Bluetooth Requirement: The sensor has an integrated Bluetooth module.

- The sensor can be operated with a smartphone/tablet (iOS or Android operating system). The required VEGA Tools app can be downloaded and installed free of charge in the respective store.
- The sensor can be adjusted with a PC/notebook (Windows operating system). The necessary adjustment software PACTware (with corresponding DTM) can be downloaded and installed free of charge on the VEGA website.

Integrated display and adjustment unit The sensor can be adjusted via the optionally integrated display and adjustment unit.



Note:

The housing with display and adjustment unit can be rotated 330° for optimum readability and operability without tools.

3.4 Packaging, transport and storage

Packaging Your instrument was protected by packaging during transport. Its capacity to handle normal loads during transport is assured by a test based on ISO 4180.

The packaging consists of environment-friendly, recyclable cardboard. For special versions, PE foam or PE foil is also used. Dispose of the packaging material via specialised recycling companies.

Transport Transport must be carried out in due consideration of the notes on the transport packaging. Nonobservance of these instructions can cause damage to the device.

Transport inspection The delivery must be checked for completeness and possible transit damage immediately at receipt. Ascertained transit damage or concealed defects must be appropriately dealt with.

Storage Up to the time of installation, the packages must be left closed and stored according to the orientation and storage markings on the outside.

Unless otherwise indicated, the packages must be stored only under the following conditions:

Storage and transport temperature

- Not in the open
- Dry and dust free
- Not exposed to corrosive media
- Protected against solar radiation
- Avoiding mechanical shock and vibration
- Storage and transport temperature see chapter "*Technical data - Ambient conditions*"
- Relative moisture 20 ... 85 %

3.5 Accessories

Accessories and related instructions can be found on our homepage.

4 Mounting

4.1 General instructions

Ambient conditions

The instrument is suitable for standard and extended ambient conditions acc. to DIN/EN/BS EN/IEC/ANSI/ISA/UL/CSA 61010-1. It can be used indoors as well as outdoors.

Process conditions



Note:

For safety reasons, the instrument must only be operated within the permissible process conditions. You can find detailed information on the process conditions in chapter "Technical data" of the operating instructions or on the type label.

Hence make sure before mounting that all parts of the instrument exposed to the process are suitable for the existing process conditions.

These are mainly:

- Active measuring component
- Process fitting
- Process seal

Process conditions in particular are:

- Process pressure
- Process temperature
- Chemical properties of the medium
- Abrasion and mechanical influences

Permissible process pressure (MWP) - Device

The permissible process pressure range is specified on the type label with "MWP" (Maximum Working Pressure). The MWP takes into account the component with the lowest pressure and may be applied permanently. This specification refers to a reference temperature of +20 °C (+68 °F).

In addition, a temperature derating of the process fitting, e. g. with flanges, can limit the permissible process pressure range according to the respective standard.



Note:

To prevent damage to the device, a test pressure may only briefly exceed the specified MWP by 1.5 times at reference temperature.

Permissible process pressure (MWP) - Mounting accessory

The permissible process pressure range is stated on the type label. The instrument should only be operated with these pressures if the mounting accessory used also fulfils these values. This should be ensured by suitable flanges, welded sockets, tension rings with Clamp connections, sealings, etc.

Protection against moisture

Protect your instrument against moisture ingress through the following measures:

- Use a suitable connection cable (see chapter "Connecting to power supply")
- Tighten the cable gland or plug connector

- Lead the connection cable downward in front of the cable entry or plug connector

This applies mainly to outdoor installations, in areas where high humidity is expected (e.g. through cleaning processes) and on cooled or heated vessels.



Note:

Make sure that during installation or maintenance no moisture or dirt can get inside the instrument.

To maintain the housing protection, make sure that the housing lid is closed during operation and locked, if necessary.

4.2 Mounting instructions

Polarisation

Radar sensors for level measurement emit electromagnetic waves. The polarization is the direction of the electrical component of these waves.

The polarisation is indicated by the position of the logo on the housing, see drawing below:

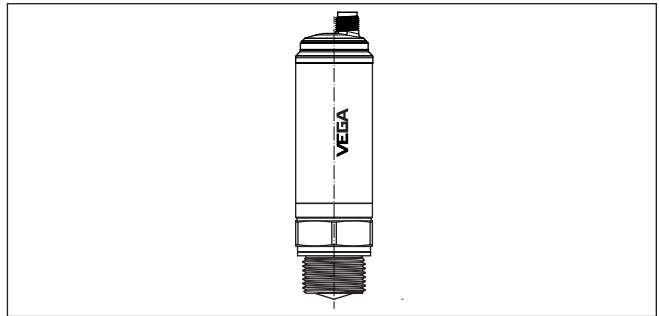

Fig. 2: Position of the polarisation



Note:

When the housing is rotated, the direction of polarization changes and hence the influence of the false echo on the measured value. Please keep this in mind when mounting or making changes later.

Reference plane

The measuring range of the VEGAPULS 42 physically begins with the antenna end.

However, the min./max. adjustment begins mathematically with the reference plane, which is located differently depending on the sensor version.

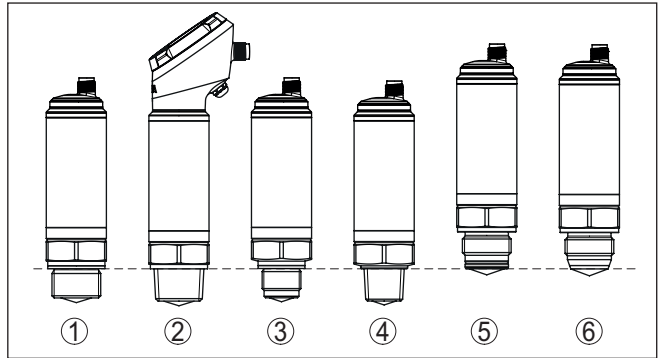

Fig. 3: Reference plane

1-4 VEGAPULS 42 with thread: The reference plane is the sealing surface at the bottom of the hexagon.

5-6 VEGAPULS 42 with hygienic fitting: The reference plane is the highest contact point between sensor process fitting and welded socket.

Installation position

When mounting the device, keep a distance of at least 200 mm (7.874 in) from the vessel wall. If the device is installed in the center of dished or round vessel tops, multiple echoes can arise. However, these can be suppressed by an appropriate adjustment (see chapter "Set up").

If you cannot maintain this distance, you should carry out a false signal suppression during setup. This applies particularly if buildup on the vessel wall is expected. In such cases, we recommend repeating the false signal suppression at a later date with existing buildup.

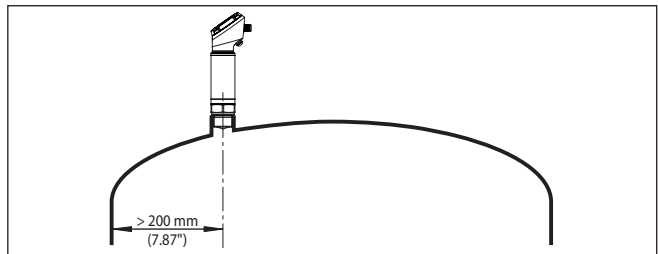

Fig. 4: Mounting of the radar sensor on round vessel tops

In vessels with conical bottom it can be advantageous to mount the device in the centre of the vessel, as measurement is then possible down to the lowest point of the bottom.

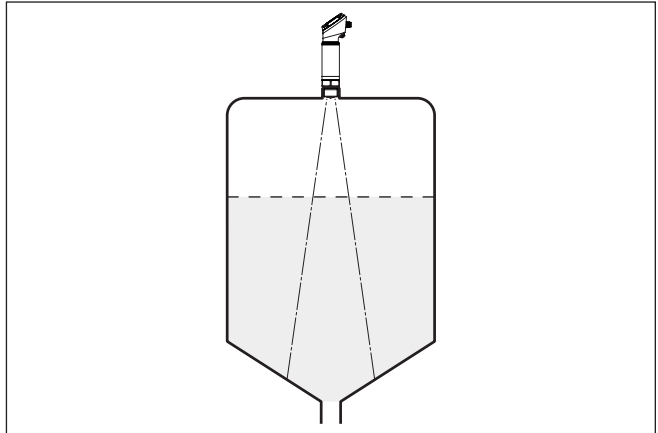

Fig. 5: Mounting of the radar sensor on vessels with conical bottom

Inflowing medium

Do not mount the instruments in or above the filling stream. Make sure that you detect the medium surface, not the inflowing product.

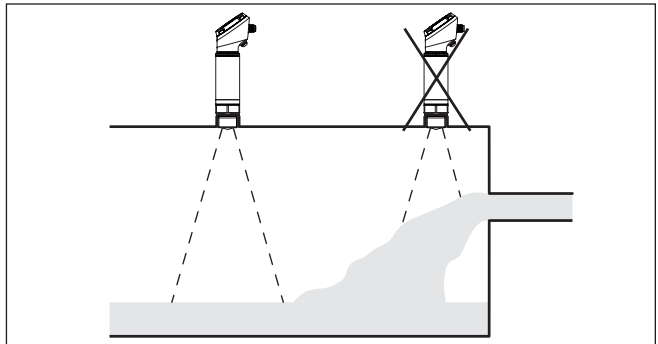

Fig. 6: Mounting of the radar sensor with inflowing medium

Threaded socket und socket piece

With threaded connection, the antenna end should protrude at least 5 mm (0.2 in) out of the nozzle.

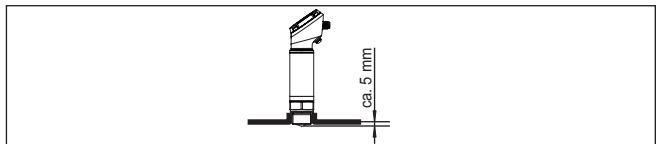

Fig. 7: Thread mounting

If the reflective properties of the medium are good, you can mount VEGAPULS 42 on sockets longer than the antenna. The socket end should be smooth and burr-free, if possible also rounded.

You will find recommended values for socket heights in the following illustration or the tables. The values come from typical applications. Deviating from the proposed dimensions, also longer sockets are possible, however the local conditions must be taken into account.

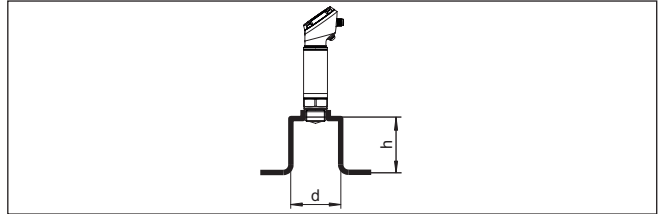

Fig. 8: Socket mounting

Socket diameter "d"		Socket length "h"	
20 mm	¾"	≤ 50 mm	≤ 2.0 in
25.4 mm	1"	≤ 100 mm	≤ 3.9 in
40 mm	1½"	≤ 150 mm	≤ 5.9 in
50 mm	2"	≤ 200 mm	≤ 7.9 in
80 mm	3"	≤ 300 mm	≤ 11.8 in
100 mm	4"	≤ 400 mm	≤ 15.8 in
150 mm	6"	≤ 600 mm	≤ 23.6 in

Tab. 1: Antenna diameter G¾, ¾ NPT

Socket diameter "d"		Socket length "h"	
25.4 mm	1"	≤ 100 mm	≤ 3.9 in
40 mm	1½"	≤ 150 mm	≤ 5.9 in
50 mm	2"	≤ 200 mm	≤ 7.9 in
80 mm	3"	≤ 300 mm	≤ 11.8 in
100 mm	4"	≤ 400 mm	≤ 15.8 in
150 mm	6"	≤ 600 mm	≤ 23.6 in

Tab. 2: Antenna diameter G1, 1 NPT



Note:

When mounting on longer nozzles, we recommend carrying out a false signal suppression (see chapter "Parameter adjustment").

Vessel installations

The mounting location of the radar sensor should be a place where no other equipment or fixtures cross the path of the radar signals.

Vessel installations, such as e.g. ladders, limit switches, heating spirals, struts, etc., can cause false echoes and impair the useful echo. Make sure when planning your measuring point that the radar sensor has a "clear view" to the measured product.

In case of existing vessel installations, a false signal suppression should be carried out during setup.

If large vessel installations such as struts or supports cause false echoes, these can be attenuated through supplementary measures. Small, inclined sheet metal baffles above the installations "scatter" the radar signals and prevent direct interfering reflections.



Fig. 9: Cover flat, large-area profiles with deflectors

Alignment - Liquids

In liquids, direct the device as perpendicular as possible to the medium surface to achieve optimum measurement results.

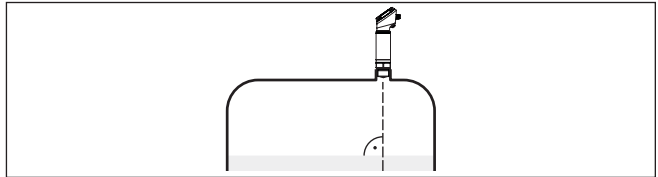

Fig. 10: Alignment in liquids

Agitators

If there are agitators in the vessel, a false signal suppression should be carried out with the agitators in motion. This ensures that the interfering reflections from the agitators are saved with the blades in different positions.

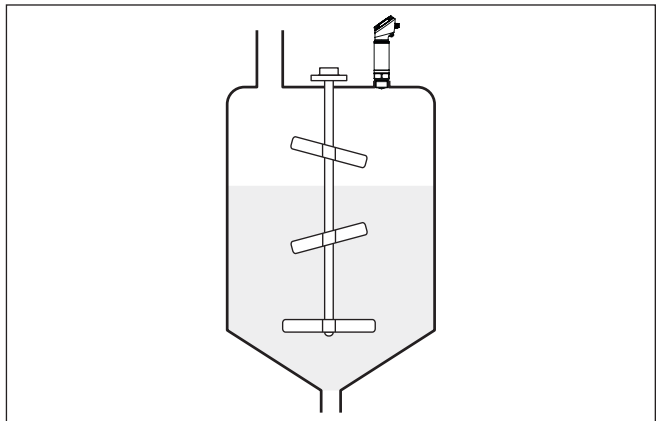

Fig. 11: Agitators

Foam generation

Through the action of filling, stirring and other processes in the vessel, compact foams which considerably damp the emitted signals may form on the medium surface.

**Note:**

If foams lead to measurement errors, you should use the biggest possible radar antennas or as an alternative, sensors with guided radar.

5 Connecting to power supply

5.1 Preparing the connection

Safety instructions

Always keep in mind the following safety instructions:

- Carry out electrical connection by trained, qualified personnel authorised by the plant operator
- If overvoltage surges are expected, overvoltage arresters should be installed



Warning:

Only connect or disconnect in de-energized state.

Voltage supply

The data for power supply are specified in chapter "*Technical data*".



Note:

Power the instrument via an energy-limited circuit (power max. 100 W) acc. to IEC 61010-1, e.g.:

- Class 2 power supply unit (acc. to UL1310)
- SELV power supply unit (safety extra-low voltage) with suitable internal or external limitation of the output current
- PELV power supply unit (protective low voltage) with suitable internal or external limitation of the output current

Keep in mind the following additional factors that influence the operating voltage:

- Lower output voltage of the power supply unit under nominal load (e.g. with a sensor current of 20.5 mA or 22 mA in case of fault signal)
- Influence of additional instruments in the circuit (see load values in chapter "*Technical data*")

Connection cable

Use cable with round cross section. Depending on the plug connection, you have to select the outer diameter of the cable respectively so that the seal effect of the cable gland is ensured.

Depending on the connection method or signal output, the device is connected with standard three or four-wire cable without shielding.

5.2 Connection procedure

M12 x 1 plug

This plug connection requires a complete confectioned cable with counter plug.

M12 x 1 plug

5.3 Wiring plan

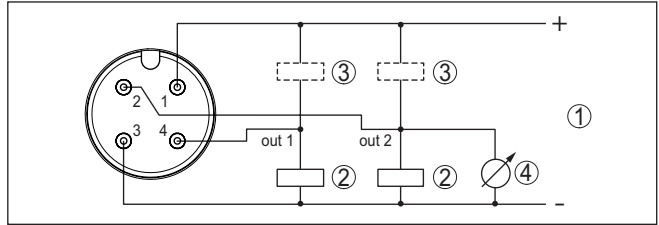

Fig. 12: Wiring plan - Three-wire with IO-Link (2 x transistor or 4 ... 20 mA plus 1 x transistor)

- 1 Voltage supply
- 2 PNP switching
- 3 NPN switching
- 4 Current output

Contact, plug connector	Function/Polarity
1	Voltage supply/Plus
2	Transistor output 2 or current output
3	Voltage supply/Minus
4	Transistor output 1 or IO-Link port

In IO-Link mode, output 2 has no function

5.4 Switch-on phase

After switching on, the device first carries out a self-check:

- Internal check of the electronics
- The output signal jumps to the set fault current¹⁾
- Switching outputs are controlled

The current measured value is then output on the signal cable.

¹⁾ With current output activated

6 Access protection

6.1 Bluetooth radio interface

Devices with a Bluetooth radio interface are protected against unwanted access from outside. This means that only authorized persons can receive measured and status values and change device settings via this interface.

Bluetooth access code

A Bluetooth access code is required to establish Bluetooth communication via the adjustment tool (smartphone/tablet/notebook). This code must be entered once when Bluetooth communication is established for the first time in the adjustment tool. It is then stored in the adjustment tool and does not have to be entered again.

The Bluetooth access code is individual for each device. It is printed on the device housing with Bluetooth. In addition, it is supplied with the device in the information sheet "*PINs and Codes*". In addition, the Bluetooth access code can be read out via the display and adjustment unit, depending on the device version.

The Bluetooth access code can be changed by the user after the first connection is established. If the Bluetooth access code is entered incorrectly, the new entry is only possible after a waiting period has elapsed. The waiting time increases with each further incorrect entry.

Emergency Bluetooth unlock code

The emergency Bluetooth access code enables Bluetooth communication to be established in the event that the Bluetooth access code is no longer known. It can't be changed. The emergency Bluetooth access code can be found in information sheet "*Access protection*". If this document is lost, the emergency Bluetooth access code can be retrieved from your personal contact person after legitimation. The storage and transmission of Bluetooth access codes is always encrypted (SHA 256 algorithm).

6.2 Protection of the parameterization

The settings (parameters) of the device can be protected against unwanted changes. The parameter protection is deactivated on delivery, all settings can be made.

Device code

To protect the parameterization, the device can be locked by the user with the aid of a freely selectable device code. The settings (parameters) can then only be read out, but not changed. The device code is also stored in the adjustment tool. However, unlike the Bluetooth access code, it must be re-entered for each unlock. When using the adjustment app or DTM, the stored device code is then suggested to the user for unlocking.

Emergency device code

The emergency device code allows unlocking the device in case the device code is no longer known. It can't be changed. The emergency device code can also be found on the supplied information sheet "*Access protection*". If this document is lost, the emergency device code can be retrieved from your personal contact person after legitimation.

The storage and transmission of the device codes is always encrypted (SHA 256 algorithm).

6.3 Storing the codes in myVEGA

If the user has a "myVEGA" account, then the Bluetooth access code as well as the device code are additionally stored in his account under "*PINs and Codes*". This greatly simplifies the use of additional adjustment tools, as all Bluetooth access and device codes are automatically synchronized when connected to the "myVEGA" account

7 Set up with the integrated display and adjustment unit

7.1 Adjustment system

Function

The instrument is operated via the three keys of the integrated display and adjustment unit. The respective menu items are shown on the LC display. You can find the function of the individual keys in the below overview.

Certain settings are only possible to a limited extent or not possible with the integrated display and adjustment unit. For these settings, we recommend using the adjustment app or PACTware with corresponding DTM.

Display and adjustment elements

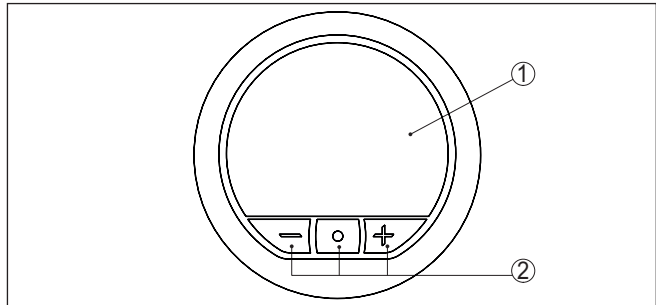

Fig. 13: Integrated display and adjustment unit

- 1 LC display
2 Adjustment keys

Key functions

Key	Function
[*]	Entry to the menu level Jump to selected menu item Edit parameter Select editing position Save value
[+]	Switching between the individual measured value windows Navigation in the menu items, forwards Change parameter values upwards
[-]	Switching between the individual measured value windows Navigation in the menu items, backwards Change parameter values downwards
[+] and [-] simultaneously	Jump to next higher menu Interrupt input

Time functions

When the **[+]** and **[-]** keys are pressed quickly, the edited value, or the cursor, changes one value or position at a time. If the key is pressed longer than 1 s, the value or position changes continuously.

Simultaneous pressing of the **[+]** and **[-]** keys causes a return to the measured value indication.

Approx. 60 minutes after the last pressing of a key, an automatic reset to measured value indication is triggered. Any values not confirmed with **[•]** will not be saved.

Measured value indication

7.2 Measured value and menu item display

Measured values are displayed according to the following presentation:

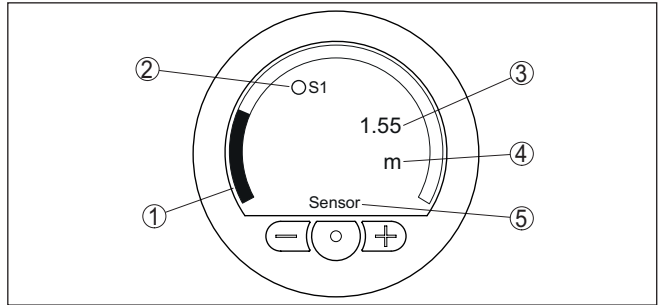

Fig. 14: Measured value, switching status and sensor TAG

- 1 Measured value as bargraph
- 2 Switching status
- 3 Measured value as digital value with unit
- 4 Unit
- 5 Sensor-TAG

Menu item display

The menu items are displayed according to the following diagram:

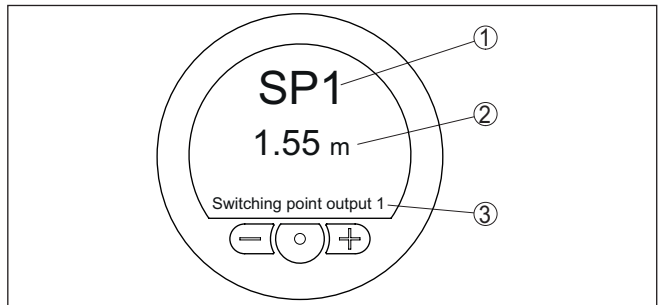

Fig. 15: Display menu item (example)

- 1 Menu item code acc. to VDMA 24574-1
- 2 Actual parameter value
- 3 Menu item name

7.3 Parameter adjustment

7.3.1 Main menu

Selection language	With the first setup, the instrument offers you a selection of the menu languages. The selection you are making here can be changed any time under " <i>Extended functions</i> ", " <i>Menu language</i> ".
Length unit	<p>In this menu item the length unit of the device is defined. The selection made determines the unit for the measuring cell temperature shown on the distance.</p> <p>Menu item code:</p> <ul style="list-style-type: none"> ● UNI <p>Parameter:</p> <ul style="list-style-type: none"> ● m ● mm ● in ● ft
Medium	This menu item enables you to adapt the sensor to the different measuring conditions of the media " <i>Liquid</i> " or " <i>Bulk solid</i> ". This selection adapts the signal processing to the expected reflections.
Application	<p>This menu item enables you to optimally adapt the sensor to the application, the place of use and the measuring conditions. The adjustment possibilities depend on the selection made under "<i>Medium</i>", "<i>Liquid</i>" or "<i>Bulk solid</i>".</p> <p>The vessels as well as the measuring and process conditions are described in the following as an overview.</p>
Application - liquid	<p>With "<i>Liquid</i>", the applications are based on the following features, to which the measuring characteristic of the sensor is adjusted in particular:</p> <p>Storage tank</p> <ul style="list-style-type: none"> ● Vessel: <ul style="list-style-type: none"> – Large volume – Upright cylindrical, horizontal round ● Process/measurement conditions: <ul style="list-style-type: none"> – Slow filling and emptying – Smooth medium surface – Multiple reflections through dished vessel ceiling – Condensation <p>Stirrer vessel</p> <ul style="list-style-type: none"> ● Vessel: <ul style="list-style-type: none"> – Large agitator blades of metal – Installations like flow breakers, heating spirals – Nozzle ● Process/measurement conditions: <ul style="list-style-type: none"> – Frequent, fast to slow filling and emptying

- Strongly agitated surface, foam and strong vortex generation
- Multiple reflections through dished vessel ceiling
- Condensation, buildup on the sensor
- Further recommendations
 - False signal suppression when the agitator is running via the operating tool

Dosing vessel

- Vessel:
 - Small vessels
- Process/measurement conditions:
 - Frequent and fast filling/emptying
 - Tight installation situation
 - Multiple reflections through dished vessel ceiling
 - Product buildup, condensate and foam generation

Demonstration

- Applications that are not typical level measurements, e.g. device tests
 - Instrument demonstration
 - Object recognition/monitoring
 - Fast position changes of a measuring plate during functional test

Application - bulk solid

With "*Bulk solid*", the applications are based on the following features, to which the measuring characteristic of the sensor is adjusted in particular:

Silo (slender and high)

- Process/measurement conditions:
 - Interfering reflections due to weld seams on the vessel
 - Multiple echoes/diffuse reflections due to unfavourable pouring positions with fine grain
 - Varying pouring positions due to outlet funnel and filling cone
- Further recommendations
 - False signal suppression via the operating tool
 - Alignment of the measurement to the silo outlet

Demonstration

- Applications that are not typical level measurements
 - Instrument demonstration
 - Object recognition/monitoring
 - Measured value verification with higher measuring accuracy with reflection without bulk solids, e.g. via a measuring plate

Vessel height

In this menu item, the vessel height can be adjusted. The adjustable max. vessel height is 15 m (49.21 ft).

Menu item code:

- VH

Switching points

In this menu item, the switching points are defined depending on the selected mode (output function).

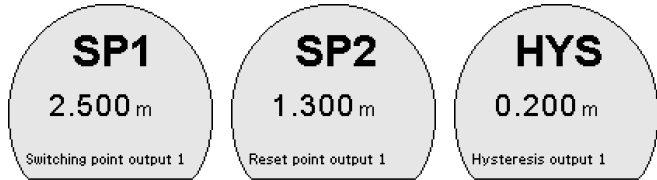

Menu item code:

- SP1
- SP2

Parameter:

- Level

Mode "Two-point"

In this mode the output (NO or NC) changes its state when the measured variable has reached the switching point (SP1). If the measured variable falls below the reset point (SP2), the output returns to its previous state.

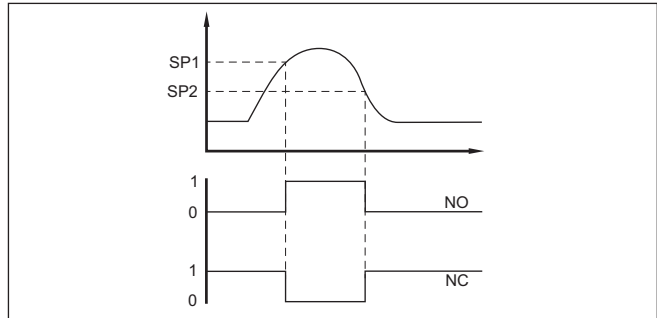

Fig. 16: Switching points in mode "Two-point" (example)

If the measured variable moves between switching and reset point, the state of the output does not change.

Mode "Single point"

In the mode "single point", the output (NO or NC) changes its state when the measured value reaches the switching point (SP1). If the measured value falls below the switching point (SP1) again, the output returns to its previous state. Optionally, a hysteresis (HYS1) can also be set. The hysteresis is subtracted from the switching point SP1.

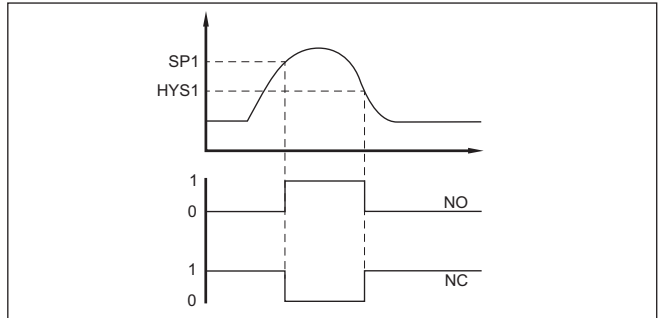

Fig. 17: Switching points in mode "Single point" (example)

If the measured value moves between switching point 1 and hysteresis (value from switching point 1 minus hysteresis), the state of the output does not change.

Mode "Window"

The output (NO or NC) changes its state when the measured variable enters the window between the switching point 1 (SP1) and switching point 2 (SP2). If the measured variable leaves the window, the output returns to its previous state.

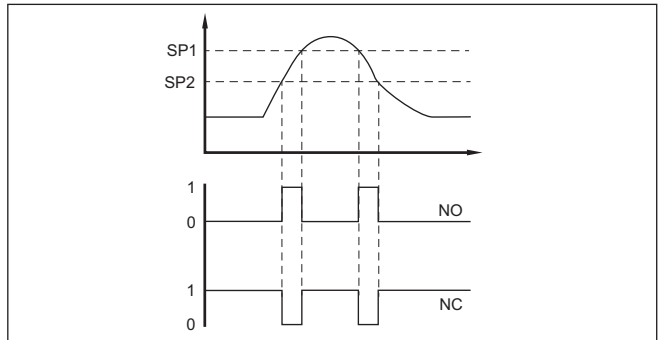
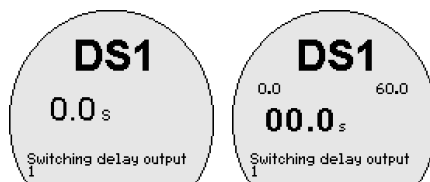

Fig. 18: Switching points in mode "Window" (example)

If the measured variable moves within the window, the state of the output does not change.

Switching delay

The switch-on and switch-off delay times are set in this menu item. The set times influence the switching points depending on the selected mode (output function).



Menu item code:

- DS
- DR

Parameter:

- Time value

Function in mode "Single point" and "Two-point"

If the measured variable has reached the set switching point 1 (SP1), the state of the output (NO or NC) does not change until the set delay time has elapsed. If the measured variable falls below the switching point again after this time has elapsed, the state of the output does not change.

If the measured variable has dropped to the reset point (SP2) or below for the duration of the reset delay time, the output switches back to its previous state.

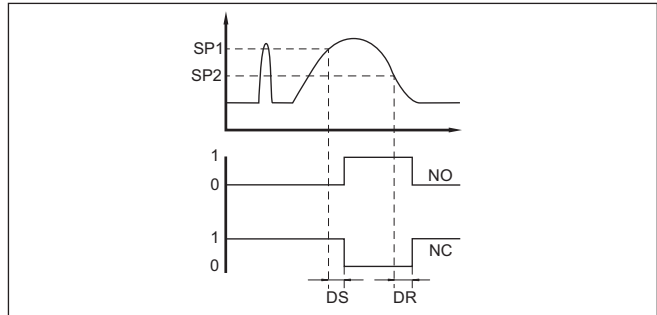

Fig. 19: Effect of the delay time in mode "Two-point" (example)

Function in mode "Window"

If the measured variable has reached the lower value of the window (SP2), the state of the output (NO or NC) does not change until this time has elapsed when the delay time has been set. If the measured value falls below the lower value of the window again after this time has elapsed, the state of the output does not change.

If the measured variable has exceeded the upper value of the window (SP1) for the duration of the reset delay time, the output switches back to its previous state.

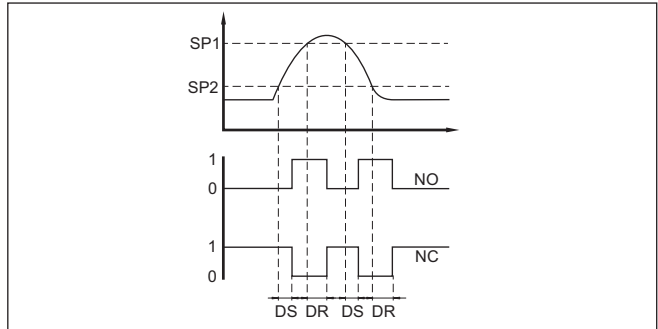

Fig. 20: Effect of the delay time in mode "Window" (example)

Access protection

In this menu item, the access to the device can be protected.

Menu item code:

- ZGS

The submenus "Bluetooth communication", "Bluetooth access code" and "Protection of the parameter adjustment" were described in the following.

Bluetooth communication

In this menu item you can activate/deactivate the Bluetooth communication of the device.

Menu item code:

- BTA

Bluetooth access code

In this menu item, you can change the factory-preset Bluetooth access code to your personal Bluetooth access code.



Note:

The individual preset Bluetooth access code of the device can be found on the supplied information sheet "PINs and Codes". If this is changed by the user and is no longer available, access is only possible via the emergency Bluetooth unlock code on the information sheet "Emergency unlock codes" also supplied.

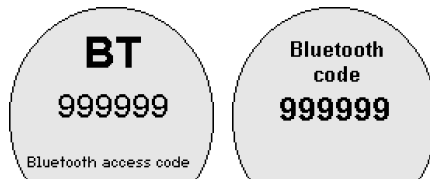

Menu item code:

- BT

Protection of the parameterization

In this menu item you safeguard the sensor parameters by entering a 6-digit device code against unauthorized or unintentional modifications.

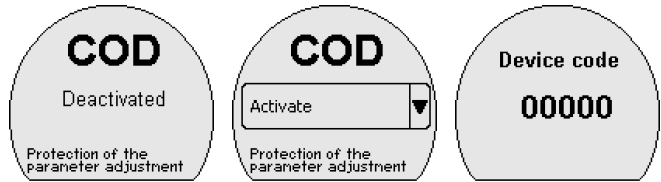

With protected parameter adjustment, the individual menu items can be selected and displayed, however the parameters can no longer be modified.

The sensor operation can also be enabled in any menu item by entering the device code. The parameter adjustment remains open until you return to the measured value display. This takes place automatically after 60 min.

Menu item code:

- COD

Parameter:

- Numerical value



Note:

The factory set device code is "000000". If this is changed by the user and is no longer available, access is only possible via the emergency device unlock code on the information sheet "*Emergency unlock codes*" also supplied.



Note:

With protected parameter adjustment, adjustment via the VEGA Tools app as well as PACTware/DTM and other systems is also blocked.

Reset

During a reset, parameter settings made by the user are reset to the values of the delivery status (see chapter "*Menu overview*"). The menu language and the Bluetooth access code are not reset.

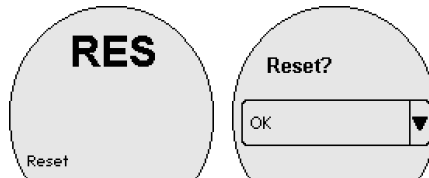

Menu item code:

- RES

Parameter:

- Reset to factory settings (Application)

Factory setting: Resets the parameter settings to the delivery status.



Information:

The current status of the access protection, the Bluetooth access code and the device code are not reset.

Extended functions, diagnosis

These menu items allow access to the menu areas "Extended functions" or "Diagnosis".

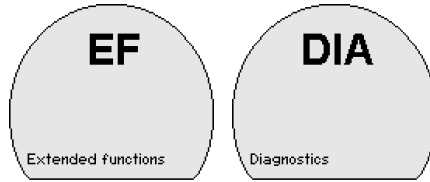

Menu item code:

- EF
- DIA

Damping

7.3.2 Extended functions

To damp process-dependent measured value fluctuations, set an integration time in this menu item.

Due to the set damping, the 4 ... 20 mA output as well as the switching output react in case of a sudden increased of the measured variable with a time-delayed slope curve.

Menu item code:

- DAM

Parameter:

- Time value

Transistor function

In this menu item the switching function of the transistor output is defined. With the PNP function, the connected load is switched against the negative cable, with the NPN function against the positive cable of the power supply (see chapter "Wiring plan").

Menu item code:

- P-N

Parameter:

- PNP
- NPN

Function outputs

In this menu item the function of the signal outputs is defined.

M12 x 1 plug:

- Two transistor outputs or
- One 4 ... 20 mA output and one transistor output



Note:

The IO-Link function is only available with "OU1".

With active IO-Link function, "OU2" is not available.

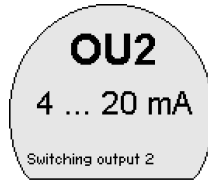

Menu item code:

- OU1
- OU2

Parameter:

- SSC
- 4 ... 20 mA

Reaction when malfunction occurs

In this menu item you define the behaviour of the current output in the event of failures.

Menu item code:

- FER

Parameter:

- ≤ 3.6 mA
- ≥ 21 mA

Display lighting

In this menu item you switch the backlight for the display off or on.

Menu item code:

- DIS

Parameter

- On
- Off

Displayed value

In the menu item "*Display value*" you define the indication of the measured values on the indication as filling height, distance, or scaled.

Menu item code:

- DVL

Scaling

In the menu items for scaling, you define how the measured value is displayed on the screen. This includes the scaling size, scaling unit and scaling format, as well as the scaling of the minimum and maximum measured values.

Menu item code:

- SCU
- SCF
- MAV
- MIV

Mode of operation

Country or region-specific settings for the radar signals are determined via the operating mode (see chapter "Technical data, Mode of operation").

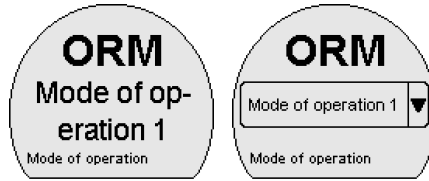

Depending on the operating mode, metrological properties of the device can change (see chapter "Technical data, input variable").

Menu item code:

- ORM

Indication of the switching status

In this menu item you define the brightness of the LED illuminated ring for the switching status display.

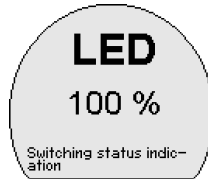

Menu item code:

- LED

Parameter

- Off
- 10 %
- 20 %
- ...
- 100 %

Menu language

This menu item enables the setting of the requested national language for the display.

Menu item code:

- LG

Parameter:

- Deutsch, Englisch, Französisch, Spanisch, Portugiesisch, Italienisch, Niederländisch, Russisch, Chinesisch, Japanisch, Koreanisch, Türkisch, Polnisch, Tschechisch

7.3.3 Diagnostics

In this menu item, the device status is displayed.

Status



Menu item code:

- STA

In the event of an error, the error code, e.g. F017, and an error description, e.g. "Adjustment span too small" are displayed.

Parameter modification counter

This menu item displays the number of parameter changes made.

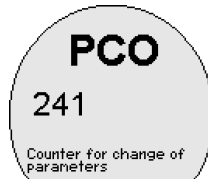

Menu item code:

- PCO

Sensor information

This menu item displays the hardware and software status as well as the serial number of the device.

Menu item code:

- INF

Parameter:

- HW
- SW
- SN

Simulation

In this menu item you simulate switching states of the transistor outputs or current values of the 4 ... 20 mA output. This allows the signal path to be tested, e.g. via downstream display instruments or the input card of the control system. The simulation values are: Distance, current value, switching status.



Note:

Make sure the connected downstream devices are activated during the simulation.

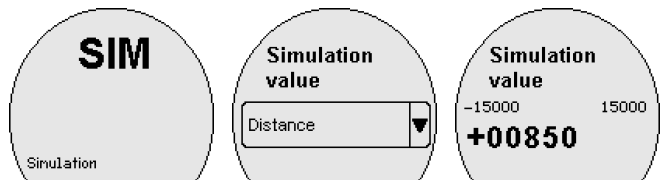

Menu item code:

- SIM

Parameter:

- Numerical value for distance or current
- Open or closed for switching output



Note:

Without manual deactivation, the sensor terminates the simulation automatically after 60 minutes.

8 Setup with smartphone/tablet (Bluetooth)

8.1 Preparations

System requirements

Make sure that your smartphone/tablet meets the following system requirements:

- Operating system: iOS 13 or newer
- Operating system: Android 5.1 or newer
- Bluetooth 4.0 LE or newer

Download the VEGA Tools app from the "Apple App Store", "Google Play Store" or "Baidu Store" to your smartphone or tablet.

8.2 Connecting

Connecting

Start the adjustment app and select the function "Setup". The smartphone/tablet searches automatically for Bluetooth-capable instruments in the area.

The message "Connecting ..." is displayed.

The devices found are listed and the search is automatically continued.

Select the requested instrument in the device list.

Authenticate

When establishing the connection for the first time, the operating tool and the sensor must authenticate each other. After the first correct authentication, each subsequent connection is made without a new authentication query.

Enter Bluetooth access code

For authentication, enter the 6-digit Bluetooth access code in the next menu window. You can find the code on the outside of the device housing and on the information sheet "Pins and Codes" in the device packaging.

For the very first connection, the adjustment unit and the sensor must authenticate each other.

Bluetooth access code OK

Enter the 6 digit Bluetooth access code of your Bluetooth instrument.

Fig. 21: Enter Bluetooth access code



Note:

If an incorrect code is entered, the code can only be entered again after a delay time. This time gets longer after each incorrect entry.

The message "Waiting for authentication" is displayed on the smartphone/tablet.

Connected

After connection, the sensor adjustment menu is displayed on the respective adjustment tool.

If the Bluetooth connection is interrupted, e.g. due to a too large distance between the two devices, this is displayed on the adjustment tool. The message disappears when the connection is restored.

Change device code

Parameter adjustment of the device is only possible if the parameter protection is deactivated. When delivered, parameter protection is deactivated by default and can be activated at any time.

It is recommended to enter a personal 6-digit device code. To do this, go to menu "Extended functions", "Access protection", menu item "Protection of the parameter adjustment".

8.3 Parameter adjustment

Enter parameters

The sensor adjustment menu is divided into two areas, which are arranged next to each other or one below the other, depending on the adjustment tool.

- Navigation section
- Menu item display

The selected menu item can be recognized by the colour change.

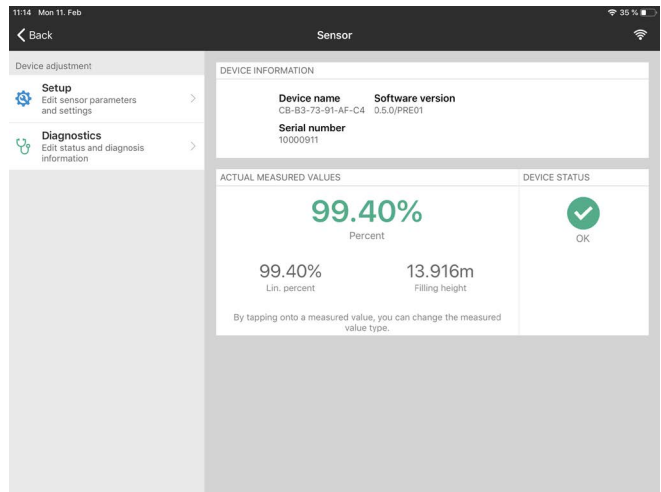

Fig. 22: Example of an app view - Setup measured values

Enter the requested parameters and confirm via the keyboard or the editing field. The settings are then active in the sensor.

Close the app to terminate connection.

9 Setup with PC/notebook (Bluetooth)

9.1 Preparations

System requirements

Make sure that your PC/notebook meets the following system requirements:

- Operating system Windows 10 or newer
- DTM Collection 10/2020 or newer
- Bluetooth 4.0 LE or newer

Activate Bluetooth connection

Activate the Bluetooth connection via the project assistant.



Note:

Older systems do not always have an integrated Bluetooth LE. In these cases, a Bluetooth USB adapter is required. Activate the Bluetooth USB adapter using the Project Wizard.

After activating the integrated Bluetooth or the Bluetooth USB adapter, devices with Bluetooth are found and created in the project tree.

9.2 Connecting

Connecting

Select the requested device for the online parameter adjustment in the project tree.

Authenticate

When establishing the connection for the first time, the operating tool and the device must authenticate each other. After the first correct authentication, each subsequent connection is made without a new authentication query.

Enter Bluetooth access code

For authentication, enter in the next menu window the 6-digit Bluetooth access code:

Fig. 23: Enter Bluetooth access code

You can find the code on the outside of the device housing and on the information sheet "PINs and Codes" in the device packaging.



Note:

If an incorrect code is entered, the code can only be entered again after a delay time. This time gets longer after each incorrect entry.

The message "Waiting for authentication" is displayed on the PC/notebook.

Connected

After connection, the device DTM appears.

If the connection is interrupted, e.g. due to a too large distance between device and adjustment tool, this is displayed on the adjustment tool. The message disappears when the connection is restored.

Change device code

Parameter adjustment of the device is only possible if the parameter protection is deactivated. When delivered, parameter protection is deactivated by default and can be activated at any time.

It is recommended to enter a personal 6-digit device code. To do this, go to menu "Extended functions", "Access protection", menu item "Protection of the parameter adjustment".

Prerequisites

9.3 Parameter adjustment

For parameter adjustment of the instrument via a Windows PC, the configuration software PACTware and a suitable instrument driver (DTM) according to FDT standard are required. The latest PACTware version as well as all available DTMs are compiled in a DTM Collection. The DTMs can also be integrated into other frame applications according to FDT standard.

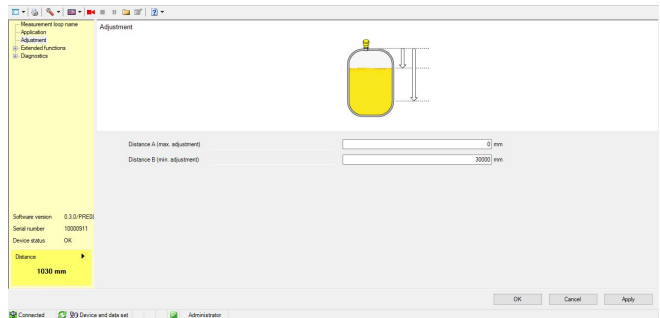

Fig. 24: Example of a DTM view - Setup, sensor adjustment

10 Menu overview

10.1 Functions and adjustment possibilities

The displayed menu points can be vary depending on the device version and adjustment tool.

The adjustment tools are:

- Display and adjustment unit
- VEGA Tools app or PACtware/DTM

Measured value indication

Naming	Menu item	Measured value window	Device status or measured value window 2
Start image	Device information, device name, software version, serial number	Filling height, distance, measurement reliability, electronics temperature, meas. rate etc.	OK, error indication
Measured value indication		Filling height digitally and analogue, switching status	Filling height digitally and analogue, switching status, sensor TAG

Basic functions

Menu item	Submenu	Selection
Setup	Measurement loop name	Sensor
	Length unit	mm, m, in, ft
	Type of medium	Liquid, bulk solid
	Application	Storage tank, stirrer vessel, dosing vessel, demonstration Silo (slender and high), demonstration
	Vessel height	0 m ... 15 m
Settings switching output 1 (SSC 1.1)	Mode of operation	Deactivated, single point, window, double point
Settings switching output 2 (SSC 1.2)	Switching point 1 (SP1)	0 m ... 15 m
	Switching point 2 (SP2)	0 m ... 15 m
Switching output 2 or SSC 1.2 can only be selected if output 2 is defined as a switching output.	Logic	Closing contact (NO), opening contact (NC)
	Switching delay (DS1, DS2)	0.000 s ... 10 s
	Reset delay (DR1, DR2)	0.000 s ... 10 s
Current output	Filling height A, max. value (20 mA)	0 m ... 15 m
	Filling height B, min. value (4 mA)	0 m ... 15 m
Access protection	Change Bluetooth access code	
	Change protection of the parameterization	
	Activate/deactivate Bluetooth	

Menu item	Submenu	Selection
Reset	Reset to default	
	Restart	

Extended functions

Menu item	Selection	Adjustment options
Units	Temperature unit of the instrument	°C, °F, K
Damping	Integration time (DAM) in s	0 ... 999 s
Output	Transistor function (P-N)	PNP, NPN
	Function output 2 (OU2)	Switching output (SSC 1.2) Current output: 4 ... 20 mA
	Reaction when malfunctions occur Function current output	≤ 3.6 mA ≥ 21 mA Last valid measured value
Adjustment with medium	Switching output selection	Output 1 (SSC 1.1) Output 1 (SSC 1.2)
	Switching point 1 (SP1)	Accept current measured value
	Switching point 2 (SP2)	Accept current measured value
	Status	SP1 success SP2 success idle
	Current output distance A (max. value)	Accept current measured value
	Current output distance B (min. value)	Accept current measured value
360° status indication	Brightness illuminated ring (LED) Indication of the switching status	0 %, 10 %, 20 %, ... 100 %
	Signalling illuminated ring	Acc. to NAMUR NE 107 Switching output Free signalling
360° status indication Switching output	Switching output	Colour selection, flashing yes/no
	Operating status	Colour selection, flashing yes/no
	Fault	Colour selection, flashing yes/no
360° status indication Free signalling	Fault	Colour selection, flashing yes/no
	Operating states	1, 2, 3, 4, 5
		For each operating status: Colour selection, flashing yes/no

Menu item	Selection	Adjustment options
False signal suppression	Create new, expand, delete	
	Sounded distance to the medium from the antenna edge	0 ... 15 m
Mode of operation	Selection of the mode according to the country of use (see chapter " <i>Technical data, Mode of operation</i> ").	Mode of operation 1 Mode of operation 2 Mode of operation 3 Mode of operation 4
Special parameters	Activate limitation of the measuring range	Activate, deactivate
	Manual limiting of measuring range	0 ... 15 m
	Factor for noise averaging rising	0 ... 10
	Factor for noise averaging falling	0 ... 10
	Activate function measurement of the " <i>first large echo</i> "	Activate, deactivate
	Amplitude difference function " <i>First large echo</i> "	0 ... 120 dB
	Adjustment in	Distance, level
Indication	Display lighting	ON, OFF
	Menu language	Deutsch, Englisch, Französisch, Spanisch, Portugiesisch, Italienisch, Niederländisch, Russisch, Chinesisch, Japanisch, Koreanisch, Türkisch, Polnisch, Tschechisch
	Displayed value	Distance, scaled
Scaling	Scaling size	Others, mass, volume, height
	Scaling unit	Unit selection depending on scaling size, user-defined
	Name of the unit	
	Scaling format	#####, ####.#, ###.##, ##.###
	Scaling	Minimum value Maximum value

Diagnostics

Menu item	Selection	Adjustment options
Status	Device status Status parameter adjustment Measured value status Status outputs Status additional measured values	
Echo curve	Indication of echo curve	

Menu item	Selection	Adjustment options
Peak indicator	Peak indicator distance, measurement reliability, meas. rate, electronic temperature	
Measured values	Measured values Additional measured values Outputs	
Simulation	Distance, current value, ... Measured value Simulation value	
Diagnostic behaviour	Behaviour with echo loss	Last valid measured value Fault message Maintenance message
	Time until fault signal	0 ... 3600 s
	Status signals: Function check Out of specification Maintenance required	Activate, deactivate
Sensor information	Device name, order number, serial number, hardware/software version, factory calibration	
Sensor characteristics	Sensor features from order text	
Parameter modification counter		

10.2 Explanation special parameters

SP01 - Activate measuring range start limiting

Measuring range start limiting is activated here. The appropriate distance value is set in the special parameter SP02.

→ Jumps in the measured value to a changing false signal in the close range can thus be prevented.



Note:

However, activation also means that the sensor no longer accepts the level echo in the event of overfilling above the measuring range begin. A measured value jump to a multiple echo may occur here.

SP02 - Manual limitation of the measuring range begin

Here, an individual limitation of the measuring range begin takes place independent of the 100 % adjustment. The entered distance value in "m" must always be between the reference plane and the maximum level.

→ Echoes between the reference plane and this value will not be detected.

SP05/06 - Factor for noise averaging rising/falling

The noise averaging is a temporal, floating average value formation of all signals received by the sensor. The set factor determines the number of averaged echo curves as a Basis 2 exponent (example: factor 2 corresponds to the averaging of 2^2 [= 4] echo curves).

→ Used for false signals caused by sporadic echoes, e.g. from agitator blades. The false signals are given a lower relevance or amplitude by a larger value of SP05. They are thus more strongly suppressed in their evaluation.

→ Use for level echoes with changing amplitude, e.g. due to a turbulent medium surface. The level echoes receive a greater relevance or constant amplitude through a larger value of SP06. They are thus increased in their evaluation.



Note:

A higher factor for noise averaging can lead to a longer reaction time or a delay of the measured value update.

SP15 - Activate "First large echo" function

When this parameter is activated, the first echo not saved as a false echo with sufficiently great amplitude is selected as a product echo.

→ This is useful for very large multiple reflections by e.g. a round vessel lid.

SP16 - Minimum amplitude "First large echo"

This parameter in "dB" determines how much smaller the useful echo amplitude may be compared to the largest echo so that it is evaluated as the first large echo and thus as a product echo

→ Up to this value, a relatively weak reflection signal of the medium is thus output as a measured value.

SP25 - Adjustment

Here you can switch over if the adjustment and the measured value output is carried out in "Distance" or "Filling height".

11 Diagnostics and servicing

11.1 Maintenance

Maintenance

If the device is used properly, no special maintenance is required in normal operation.

Precaution measures against buildup

In some applications, buildup on the antenna system can influence the measuring result. Depending on the sensor and application, take measures to avoid heavy soiling of the antenna system. If necessary, clean the antenna system in certain intervals.

Cleaning

The cleaning helps that the type label and markings on the instrument are visible.

Take note of the following:

- Use only cleaning agents which do not corrode the housings, type label and seals
- Use only cleaning methods corresponding to the housing protection rating

11.2 Rectify faults

Reaction when malfunction occurs

The operator of the system is responsible for taking suitable measures to rectify faults.

Causes of malfunction

The device offers maximum reliability. Nevertheless, faults can occur during operation. These may be caused by the following, e.g.:

- Sensor
- Process
- Voltage supply
- Signal processing

Fault rectification

The first measures are:

- Evaluation of fault messages
- Checking the output signal
- Treatment of measurement errors

A smartphone/tablet with the adjustment app or a PC/notebook with the software PACTware and the suitable DTM offer you further comprehensive diagnostic possibilities. In many cases, the causes can be determined in this way and the faults eliminated.

Reaction after fault rectification

Depending on the reason for the fault and the measures taken, the steps described in chapter "Setup" must be carried out again or must be checked for plausibility and completeness.

24 hour service hotline

Should these measures not be successful, please call in urgent cases the VEGA service hotline under the phone no. **+49 1805 858550**.

The hotline is also available outside normal working hours, seven days a week around the clock.

Since we offer this service worldwide, the support is provided in English. The service itself is free of charge, the only costs involved are the normal call charges.

11.3 Diagnosis, fault messages

4 ... 20 mA signal

Connect a multimeter in the suitable measuring range according to the wiring plan. The following table describes possible errors in the current signal and helps to eliminate them:

Error	Cause	Rectification
4 ... 20 mA signal not stable	Fluctuating measured value	Set damping
4 ... 20 mA signal missing	Electrical connection faulty	Check connection, correct, if necessary
	Voltage supply missing	Check cables for breaks; repair if necessary
	Operating voltage too low, load resistance too high	Check, adapt if necessary
Current signal greater than 22 mA, less than 3.6 mA	Sensor electronics defective	Replace device or send in for repair depending on device version

LED illuminated ring

The 360° status indication on the device (see chapter "*Configuration*") shows the following:

- Device status
- Switching status of the transistor output
- Operating status²⁾

This enables simple on-site diagnosis without tools, see the following table:

LED illuminated ring			Transistor output
Colour ³⁾	Permanent light	Flashing	
Green	voltage supply on, operation without failure	Message acc. to NE 107 " <i>Maintenance required</i> " available	open (high-resistance)
Yellow		-	closed (low-resistance)
Red	voltage supply on, operation with failure	Message acc. to to NE 107 " <i>Function check</i> ", " <i>Out of specification</i> " or " <i>Simulation state</i> " is displayed	open (high-resistance)



Note:

For devices with M12 x 1 stainless steel plug, the 360° status indication is not available.

²⁾ Signalling of level ranges by colour and flashing, adjustable via VEGA Tools app or PACTware/DTM.

³⁾ Delivery status; adjustable via VEGA Tools app or PACTware/DTM

11.4 Status messages according to NE 107

The instrument features self-monitoring and diagnostics according to NE 107 and VDI/VDE 2650. In addition to the status messages in the following tables there are more detailed error messages available under the menu item "Diagnostics" via the respective adjustment module.

Status messages

The status messages are divided into the following categories:

- Failure
- Function check
- Out of specification
- Maintenance required

and explained by pictographs:

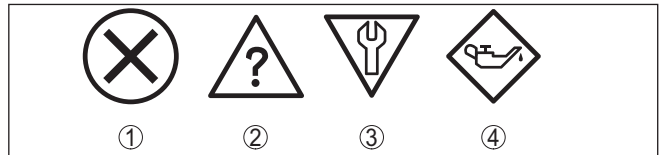

Fig. 25: Pictographs of the status messages

- 1 Failure - red
- 2 Out of specification - yellow
- 3 Function check - orange
- 4 Maintenance required - blue

Malfunction (Failure):

Due to a malfunction in the instrument, a fault signal is output.

This status message is always active. It cannot be deactivated by the user.

Function check:

The instrument is being worked on, the measured value is temporarily invalid (for example during simulation).

This status message is inactive by default.

Out of specification:

The measured value is unreliable because an instrument specification was exceeded (e.g. electronics temperature).

This status message is inactive by default.

Maintenance required:

Due to external influences, the instrument function is limited. The measurement is affected, but the measured value is still valid. Plan in maintenance for the instrument because a failure is expected in the near future (e.g. due to buildup).

This status message is inactive by default.

Failure

Code Text message	Cause	Rectification
F013 no measured value available	No measured value in the switch-on phase or during operation	Check or correct installation and/or parameter settings Clean the antenna system
F017 Adjustment span too small	Adjustment not within specification	Change adjustment according to the limit values (difference between min. and max. ≥ 10 mm)
F040 Error in the electronics	Limit value exceeded in signal processing Hardware error	Restart instrument Send instrument for repair
F080 General software error	General software error	Restart instrument
F111 Switching points interchanged	Switching point 1 is smaller than switching point 2	Select switching point 1 to greater than switching point 2

Function check

Code Text message	Cause	Rectification
C700 Simulation active	A simulation is active	Finish simulation Wait for the automatic end after 60 mins.

Out of specification

Code Text message	Cause	Rectification
S600 Impermissible electronics temperature	Temperature of the electronics in the non-specified range	Check ambient temperature Insulate electronics
S601 Overfilling	Danger of vessel overfilling	Make sure that there is no further filling Check level in the vessel

Maintenance

Code Text message	Cause	Rectification
M500 Error in the delivery status	The data could not be restored during the reset to delivery status	Repeat reset Load XML file with sensor data into the sensor
M504 Error at a device interface	Interference of the internal communication to Bluetooth	Restart Send instrument for repair
M507 Error in the instrument settings	Error during setup Error when carrying out a reset False signal suppression faulty	Carry out reset and repeat setup

Code Text message	Cause	Rectification
M508 No executable Bluetooth software	Checksum error in Bluetooth software	Carry out software update

11.5 Treatment of measurement errors

The tables below give typical examples of application-related measurement errors.

The images in column "Error description" show the actual level as a dashed line and the output level as a solid line.

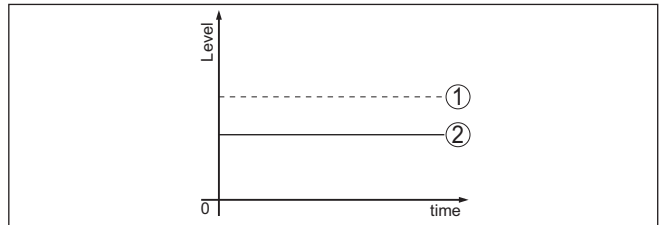

- 1 Real level
- 2 Level displayed by the sensor





Note:

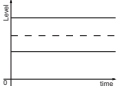

If the output level is constant, the cause could also be the fault setting of the current output to "Hold value".

If the level is too low, the reason could be a line resistance that is too high

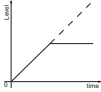
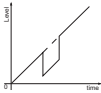
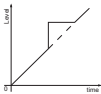

Liquids: Measurement error at constant level

Fault description	Cause	Rectification
Measured value shows a too low or too high level 	Min./max. adjustment not correct	Adapt min./max. adjustment
Measured value jumps towards 100 % 	Due to the process, the amplitude of the level echo sinks A false signal suppression was not carried out	Carry out a false signal suppression
	Amplitude or position of a false signal has changed (e.g. condensation, build-up); false signal suppression no longer matches actual conditions	Determine the reason for the changed false signals, carry out false signal suppression, e.g. with condensation.

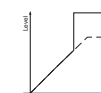
Liquids: Measurement error during filling

Fault description	Cause	Rectification
<p>Measured value remains unchanged during filling</p> 	<p>False signals in the close range too big or level echo too small</p> <p>Strong foam or vortex generation</p> <p>Max. adjustment not correct</p>	<p>Eliminate false signals in the close range</p> <p>Check measuring point: Antenna should protrude out of the threaded mounting socket, possible false echoes through flange socket?</p> <p>Remove contamination on the antenna</p> <p>In case of interferences due to installations in the close range, change polarisation direction</p> <p>Create a new false signal suppression</p> <p>Adapt max. adjustment</p>
<p>Measured value jumps towards 0 % during filling</p> 	<p>The level echo cannot be distinguished from the false signal at a false signal position (jumps to multiple echo)</p>	<p>In case of interferences due to installations in the close range: Change polarisation direction</p> <p>Chose a more suitable installation position</p>
<p>Measured value jumps towards 100 % during filling</p> 	<p>Due to strong turbulence and foam generation during filling, the amplitude of the level echo sinks. Measured value jumps to false signal</p>	<p>Carry out a false signal suppression</p>
<p>Measured value jumps sporadically to 100 % during filling</p> 	<p>Varying condensation or contamination on the antenna</p>	<p>Carry out a false signal suppression or increase false signal suppression with condensation/contamination in the close range by editing</p>
<p>Measured value jumps to $\geq 100\%$ or 0 m distance</p> 	<p>Level echo is no longer detected in the close range due to foam generation or false signals in the close range. The sensor goes into overflow protection mode. The max. level (0 m distance) as well as the status message "Overflow protection" are output.</p>	<p>Check measuring point: Antenna should protrude out of the threaded mounting socket, possible false echoes through flange socket?</p> <p>Remove contamination on the antenna</p>

Liquids: Measurement error during emptying

Fault description	Cause	Rectification
<p>Measured value remains unchanged in the close range during emptying</p> 	<p>False signal larger than the level echo Level echo too small</p>	<p>Check measuring point: Antenna should protrude out of the threaded mounting socket, possible false echoes through flange socket?</p> <p>Remove contamination on the antenna</p> <p>In case of interferences due to installations in the close range: Change polarisation direction</p> <p>After eliminating the false signals, the false signal suppression must be deleted. Carry out a new false signal suppression</p>
<p>Measured value jumps sporadically towards 100 % during emptying</p> 	<p>Varying condensation or contamination on the antenna</p>	<p>Carry out false signal suppression or increase false signal suppression in the close range by editing</p> <p>With bulk solids, use radar sensor with purging air connection</p>

11.6 Software update

The device software is updated via Bluetooth.

The following components are required:

- Instrument
- Voltage supply
- PC/notebook with PACTware/DTM and Bluetooth USB adapter
- Current instrument software as file

You can find the current instrument software as well as detailed information on the procedure in the download area of our homepage: www.vega.com.



Caution:

Instruments with approvals can be bound to certain software versions. Therefore make sure that the approval is still effective after a software update is carried out.

You can find detailed information in the download area at www.vega.com.

11.7 How to proceed if a repair is necessary

On our homepage you will find detailed information on how to proceed in the event of a repair.

So that we can carry out the repair quickly and without queries, generate a instrument return form there with the data of your device.

The following is required:

- The serial number of the instrument
- A short description of the fault

- Details of the medium, if applicable

Print the generated instrument return form.

Clean the instrument and pack it damage-proof.

Send the printed instrument return form and possibly a safety data sheet together with the device.

You will find the address for the return on the generated instrument return form.

12 Dismount

12.1 Dismounting steps

To remove the device, carry out the steps in chapters "*Mounting*" and "*Connecting to power supply*" in reverse.



Warning:

When dismantling, pay attention to the process conditions in vessels or pipelines. There is a risk of injury, e.g. due to high pressures or temperatures as well as aggressive or toxic media. Avoid this by taking appropriate protective measures.

12.2 Disposal



Pass the instrument on to a specialised recycling company and do not use the municipal collecting points.

Remove any batteries in advance, if they can be removed from the device, and dispose of them separately.

If personal data is stored on the old device to be disposed of, delete it before disposal.

If you have no way to dispose of the old instrument properly, please contact us concerning return and disposal.

13 Certificates and approvals

13.1 Radio licenses

Radar

The device has been tested and approved in accordance with the current edition of the applicable country-specific norms or standards.

The confirmations as well as regulations for use can be found in the information sheet "*Radio licenses*" supplied or on our homepage.

Bluetooth

The Bluetooth radio module in the device has been tested and approved according to the current edition of the applicable country-specific norms or standards.

The confirmations as well as regulations for use can be found in the document "*Radio licenses*" supplied or on our homepage.

13.2 Food and pharmaceutical certificates

Versions for use in the food and pharmaceutical industries are available or in preparation for the device or the device series.

The corresponding certificates can be found on our homepage.

13.3 Conformity

The device complies with the legal requirements of the applicable country-specific directives or technical regulations. We confirm conformity with the corresponding labelling.

The corresponding conformity declarations can be found on our homepage.

13.4 NAMUR recommendations

NAMUR is the automation technology user association in the process industry in Germany. The published NAMUR recommendations are accepted as the standard in field instrumentation.

The device fulfils the requirements of the following NAMUR recommendations:

- NE 21 – Electromagnetic compatibility of equipment
- NE 43 – Signal level for fault information from measuring transducers
- NE 53 – Compatibility of field devices and display/adjustment components
- NE 107 – Self-monitoring and diagnosis of field devices

For further information see www.namur.de.

13.5 Environment management system

Protection of the environment is one of our most important duties. That is why we have introduced an environment management system with the goal of continuously improving company environmental pro-

tection. The environment management system is certified according to DIN EN ISO 14001.

Help us to meet these requirements and observe the environmental instructions in the chapters "*Packaging, transport and storage*", "*Disposal*" of this instructions manual.

14 Supplement

14.1 Technical data

Note for approved instruments

The technical data in the respective safety instructions which are included in delivery are valid for approved instruments (e.g. with Ex approval). These data can differ from the data listed herein, for example regarding the process conditions or the voltage supply.

All approval documents can be downloaded from our homepage.

Materials and weights

Materials, wetted parts

Process fitting	316L
Antenna	PEEK or PTFE
Process seal	FKM, EPDM, FFKM

Materials, non-wetted parts

Electronics housing	316L und PBT/PC
Illuminated ring	PC
M12 x 1 plug connector	
– Contact support	PBT/PC
– Contacts	CuZn, nickel layer and 0.8 µm gold-plated
Weight	approx. 0.5 kg (1.12 lbs)

Torques

Thread G $\frac{3}{4}$, $\frac{3}{4}$ NPT	75 Nm (55.32 lbf ft)
Thread G1, 1 NPT	100 Nm (73.76 lbf ft)
Thread G1 with O-ring	25 Nm (18.44 lbf ft)
Thread G1 with conus	100 Nm (73.76 lbf ft)

Input variable

Measured variable	The measured variable is the distance between the antenna edge of the sensor and the medium surface. The antenna edge is also the reference plane for the measurement.
Max. measuring range	15 m (49.21 ft)
Recommended measuring range	up to 10 m (32.81 ft)
blocking distance ⁴⁾	
– Modes of operation 1, 2, 4	0 mm (0 in)
– Mode of operation 3	≥ 250 mm (9.843 in)

⁴⁾ Depending on the operating conditions

Mode of operation

Mode of operation 1	EU, Albania, Andorra, Azerbaijan, Australia, Belarus, Bosnia and Herzegovina, Canada, Egypt, Liechtenstein, Morocco, Moldavia, Monaco, Montenegro, New Zealand, Northern Macedonia, Norway, San Marino, Saudi Arabia, Serbia, South Africa, Switzerland, Turkey, Ukraine, United Kingdom, USA
Mode of operation 2	Brazil, Japan, South Korea, Taiwan, Thailand
Mode of operation 3	Chile, India, Malaysia, Zimbabwe
Mode of operation 4	Russia, Kazakhstan

Switch-on phase

Run-up time for U_B	< 5 s
Starting current active current output	≤ 3.6 mA
IO-Link communication readiness	3 s

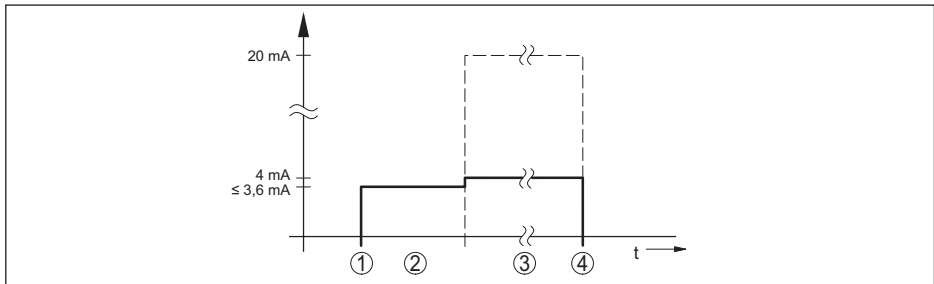

Fig. 26: Run-up time and measured value output

- 1 U_B On
- 2 Run-up time
- 3 Measured value output
- 4 U_B Off

Output variable - three-wire 4 ... 20 mA

Output signal	4 ... 20 mA (active)
Connection technology	Three-wire
Range of the output signal	3.8 ... 20.5 mA (default setting)
Signal resolution	5 μ A
Fault signal, current output (adjustable)	Last valid measured value, ≥ 21 mA, ≤ 3.6 mA (Default)
Max. output current	21.5 mA
Load	See load resistance under Power supply

Output variable - Three-wire 1 x transistor

Output signal	Transistor PNP or NPN can be configured
Connection technology	Three-wire
Load current	max. 250 mA
Overload resistance	yes

1016153-EN-250813

Short-circuit resistance	Permanently
Voltage loss	< 3 V
Inverse current PNP	< 16 μ A
Inverse current NPN	< 32 μ A

Output variable - Three-wire 2 x transistor

Output signal	Transistor PNP or NPN can be configured
Connection technology	Three-wire
Load current	max. 250 mA
Overload resistance	yes
Short-circuit resistance	Permanently
Voltage loss	< 3 V
Inverse current PNP	< 10 μ A
Inverse current NPN	< 25 μ A
Function	
– Output 1	Switching output or IO-Link
– Output 2	Switching output or 4 ... 20 mA (active) In IO-Link mode, output 2 has no function

Output variable - Three-wire IO-Link

Output signal	IO-Link acc. to IEC 61131-9
---------------	-----------------------------

Dynamic behaviour output

Reaction time transistor output with switching relevant change of the process variable total	≤ 10 ms
Damping (63 % of the input variable)	0 ... 9 s, adjustable

Deviation (according to DIN EN 60770-1)

Process reference conditions according to DIN EN 61298-1

– Temperature	+18 ... +30 °C (+64 ... +86 °F)
– Relative humidity	45 ... 75 %
– Air pressure	860 ... 1060 mbar/86 ... 106 kPa (12.5 ... 15.4 psig)

Installation reference conditions⁵⁾

– Min. distance to internal installations	> 200 mm (7.874 in)
– Reflector	Flat plate reflector
– False reflections	Biggest false signal, 20 dB smaller than the useful signal
Deviation with liquids	≤ 2 mm (meas. distance > 0.25 m/0.8202 ft)

⁵⁾ In case of deviations from reference conditions, the offset due to installation can be up to ± 4 mm. This offset can be compensated by the adjustment.

Non-repeatability⁶⁾

≤ 1 mm

Deviation with bulk solids

The values depend to a great extent on the application. Binding specifications are thus not possible.

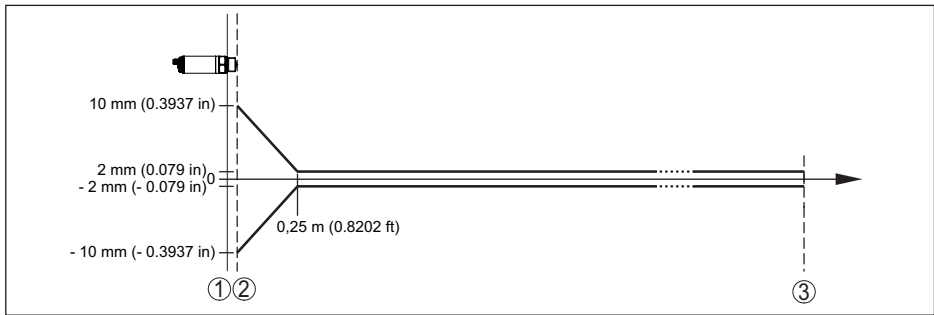

Fig. 27: Deviation under reference conditions

- 1 Reference plane
- 2 Antenna edge
- 3 Recommended measuring range

Characteristics and performance data

Radar signal	FMCW (Frequency-Modulated-Continuous-Wave)
Measuring frequency	W-band (80 GHz technology)
Measuring cycle time (with operating voltage $U_b \geq 24$ V DC)	≤ 60 ms
Step response time ⁷⁾	≤ 1 s
Beam angle ⁸⁾	
- G ^{3/4} , 3/4 NPT	14°
- G1, 1 NPT	12°
- G1 for hygienic adapter	13°
Emitted HF power (depending on the parameter setting ⁹⁾)	
- Average spectral transmission power density	-3 dBm/MHz EIRP
- Max. spectral transmission power density	+34 dBm/50 MHz EIRP
- Max. power density at a distance of 1 m	< 3 μW/cm ²

⁶⁾ Already included in the meas. deviation

⁷⁾ Time span after a sudden distance change from 1 m to 5 m until the output signal reaches 90 % of the final value for the first time (IEC 61298-2). Valid with operating voltage $U_b \geq 24$ V DC.

⁸⁾ Outside the specified beam angle, the energy level of the radar signal is 50% (-3 dB) less.

⁹⁾ EIRP: Equivalent Isotropic Radiated Power

Ambient conditions

Ambient temperature device	-40 ... +70 °C (-40 ... +158 °F)
Ambient temperature display	-25 ... +70 °C (-13 ... +158 °F)
Storage and transport temperature	-40 ... +80 °C (-40 ... +176 °F)

Mechanical environmental conditions

Vibration resistance	5 g (5 ... 200 Hz) IEC 60068-2-6
Shock resistance	10 g/11 ms, 30 g/6 ms, 50 g/2.3 ms IEC 60068-2-27
Impact resistance	7 J (plastic lid IK06 acc. to IEC 62262)

Process conditions

For the process conditions, please also note the specifications on the type label. The lowest value (amount) always applies.

Process pressure	-1 ... 16 bar (-100 ... 1600 kPa/-14.5 ... 232.06 psig)
Process temperature	-40 ... +130 °C (-40 ... +266 °F)

Temperature derating

Fig. 28: Temperature derating VEGAPULS 42

- 1 Process temperature
2 Ambient temperature

Sterilization in place (SIP) process temperature

After prior Cleaning in place (CIP) cleaning up to max. +80 °C (+176 °F):

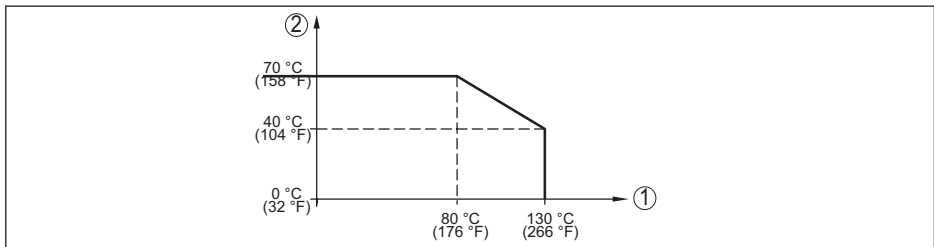
SIP process temperature with vapour stratification up to

- 15 minutes	+150 °C (+302 °F)
- 30 minutes	+140 °C (+284 °F)
- 1 hour	+135 °C (+275 °F)

Electromechanical data

Round plug connector	4-pole with M12 x 1 screw connection
----------------------	--------------------------------------

Bluetooth interface

Bluetooth standard	Bluetooth 5.0
Frequency	2.402 ... 2.480 GHz
Max. emitted power	+2.2 dBm
Max. number of participants	1

Effective range typ.¹⁰⁾ 25 m (82 ft)

Indication

Status indication LED illuminated ring (green-yellow-red)

Adjustment

PC/Notebook	PACTware/DTM
Smartphone/Tablet	Adjustment app
IO-Link master	IODD

Voltage supply

Operating voltage U_B	12 ... 35 V DC
Operating voltage U_B - IO-Link communication	18 ... 35 V DC
Max. power consumption ¹¹⁾	
– Sensor	3.5 W
– Load per transistor output ¹²⁾	9 W
Reverse voltage protection	Integrated
Permissible residual ripple	
– for U_N 12 V DC ($12\text{ V} < U_B < 18\text{ V}$)	$\leq 0.7 V_{\text{eff}}$ (16 ... 400 Hz)
– for U_N 24 V DC ($18\text{ V} < U_B < 35\text{ V}$)	$\leq 1 V_{\text{eff}}$ (16 ... 400 Hz)
Max. load resistor	
– Operating voltage $U_B = 12\text{ V DC}$	370 Ω
– Operating voltage $U_B = 18\text{ V DC}$	630 Ω

Electrical protective measures

Potential separation Electronics potential free up to 500 V AC

Protection rating

Connection technology	Protection acc. to IEC/EN 60529	Protection according to UL 50E
M12 x 1 plug (metal)	IP66/IP67/IP69	Type 6P

Connection technology	Protection acc. to IEC/EN 60529	Protection acc. to NEMA 250 ¹³⁾
M12 x 1 plug (plastic)	IP66/IP67/IP69	Type 6P
M12 x 1 plug (Display versions)	IP66/IP67	Type 6P

¹⁰⁾ Depending on the local conditions; with M12 x 1 plug stainless steel (closed full metal housing) effective range up to approx. 5 m (16.40 ft)

¹¹⁾ $U_B = 35\text{ V DC}$, output signal = 20 mA

¹²⁾ Load current = 250 mA

¹³⁾ Not verified according to UL

Altitude above sea level	≤ 5000 m (≤ 16404 ft)
Protection class	III
Pollution degree	4

14.2 IO-Link

In the following, the necessary device-specific details are shown. You can find further information of IO-Link on www.io-link.com.

Physical layer

IO-Link specification: Revision 1.1

SIO mode: Yes

Speed: COM2 38.4 kBaud

Min. cycle time 5.0 ms

Length process data word: 48 Bit

IO-Link Data Storage: Yes

Block parameter adjustment: Yes

Direct parameter

Byte	Parameter	HexCode	Remark, value
0	-	-	-
2	MasterCycleTime	-	-
3	MinCycleTime	0x28	5 ms
4	M-SequenceCapability	0x2B	Frametypes, SIO-Mode, ISDU
5	Revision ID	0x11	IO-Link Revision 1.1
6	Input process data length	-	6 Byte
7	Output process data length	-	0 Byte
8, 9	VendorID	0x00, 0x62	98
10, 11, 12	DeviceID	0x00, 0x10, 0x00	4096

Process data word

Configuration

Bit	47 (MSB)	...	16	15	...	2	1	0 (LSB)
Sensor	Measured value in m (0 ... 15 m)			free			Out2	Out1

Formats

	Value	Type
Out1	1 Bit	Boolean
Out2	1 Bit	Boolean

	Value	Type
Measured value	32 Bit	Float

Events

	HexCode	Type
6202	0x183A	FunctionCheck
6203	0x183B	Maintenance
6204	0x183C	OutOfSpec
6205	0x183D	Failure

Device data ISDU

Device data can be parameters, identification data and diagnostic information. They are exchanged acyclically and on request of the IO-Link master. Device data can be written to the sensor (write) or read from the device (read). The ISDU (Indexed Service Data Unit) determines, among other things, whether the data is read or written.

IO-Link specific device data

Data	ISDU (dez)	ISDU (hex)	Size (Byte)	Data type	Access	Value
DeviceAccess	12	0x000C	2	U16	R	-
Profile Identification	13	0x000D	2	U16	R	0x0018 0x4000
PD-Descriptor	14	0x000E	12	U8[12]	R	-
VendorName	16	0x0010	32	String32	R	VEGA Grieshaber KG
VendorText	17	0x0011	32	String32	R	www.vega.com
ProductName	18	0x0012	32	String32	R	VEGAPULS
ProductID	19	0x0013	32	String32	R	VEGAPULS 42
ProductText	20	0x0014	32	String32	R	Level sensor
SerialNumber	21	0x0015	16	String16	R	-
HardwareRevision	22	0x0016	20	String20	R	-
SoftwareRevision	23	0x0017	20	String20	R	-
ApplicationSpecificTag	24	0x0018	32	String32	R/W	***
FunctionTag	25	0x0019	32	String32	R/W	***
LocationTag	26	0x001A	32	String32	R/W	***
DeviceStatus	36	0x0024	1	U8	R	-
DetailedDeviceStatus	37	0x0025	12	U8[12]	R	-
PDin	40	0x0028	6	-	R	See process data word
Teach Select	58	0x003A	1	U8	W	1 = Channel 1 2 = Channel 2

Data	ISDU (dez)	ISDU (hex)	Size (Byte)	Data type	Access	Value
Teach Result State	59	0x003B	1	U8	R	0 = Idle 1 = SP1 success 2 = SP2 success 4 = Wait for command 5 = Busy 7 = Error
SSC1.1 Param	60	0x003C	8	Float[2]	R/W	see IO-Link Profile Smart Sensors 2nd Edition Version 1.1 September 2021
SSC1.1 Config	61	0x003D	6	Struct	R/W	
SSC1.2 Param	62	0x003E	8	Float[2]	R/W	
SSC1.2 Config	63	0x003F	6	Struct	R/W	
MSDSC Descr	16512	0x4080	11	Struct	R	

VEGA-specific device data

Data	ISDU (dez)	ISDU (hex)	Size (Byte)	Data type	Access	Value range
Measurement loop name (TAG)	261	0x0105	19	String19	R/W	-
Mode of operation	265	0x0109	2	U16	R/W	0 = operation mode 1 1 = operation mode 2 2 = operation mode 3 3 = operation mode 4 See chapter "Technical data, Mode of operation"
Device Revision	267	0x010B	2	U16	R	-
Unit of Length	268	0x010C	2	U16	R/W	1010 = m 1013 = mm 1018 = ft 1019 = in
Temperature unit	269	0x010D	2	U16	R/W	1000 = K 1001 = °C 1002 = °F
Type of medium	270	0x010E	1	U8	R/W	0 = Liquids 1 = Bulk solid
Liquids Application	271	0x010F	1	U8	R/W	0 = Storage tank 1 = Stirred vessel 4 = Dosing vessel 12 = Demonstration
Solids Application	272	0x0110	1	U8	R/W	0 = Silo 5 = Demonstration
Vessel height D	273	0x0111	4	Float	R/W	0 ... 15000

Data	ISDU (dez)	ISDU (hex)	Size (Byte)	Data type	Access	Value range
Distance A (20 mA)	274	0x0112	4	Float	R/W	0 ... 15000
Distance B (4 mA)	275	0x0113	4	Float	R/W	0 ... 15000
Behaviour in case of failure	276	0x0114	1	U8	R/W	0 = ≤ 3.6 mA 3 = Last valid measured value 4 = ≥ 21.5 mA
Filling height A (20 mA)	277	0x0115	4	Float	R/W	0 ... 15000
Filling height B (4 mA)	278	0x0116	4	Float	R/W	0 ... 15000
Bluetooth access code	279	0x0117	6	String6	R/W	Numerical value
Protection of parameter adjustment	280	0x0118	1	U8	R	0 = deactivated 1 = activated
Brightness illuminated ring	281	0x0119	1	U8	R/W	0 ... 100 % in 10 % steps
Signalling illuminated ring	282	0x011A	1	U8	R/W	0 = switching output 1 = Acc. to NAMUR NE 107 2 = free signalling
Signaling switching output: Failure	283	0x011B	1	U8	R/W	0=Individually colour, 1=Red, 2=Orange, 3=White, 4=Green, 5=Blue, 6=Yellow, 7=No signalling
Signaling switching output: Failure Flashing	284	0x011C	1	U8	R/W	0 = No, 1 = Yes
Signaling switching output: Switching output	285	0x011D	1	U8	R/W	0=Individually colour, 1=Red, 2=Orange, 3=White, 4=Green, 5=Blue, 6=Yellow, 7=No signalling
Signaling switching output: switching output Flashing	286	0x011E	1	U8	R/W	0=No, 1= Yes
Signaling switching output: Operating status	287	0x011F	1	U8	R/W	0=Individually colour, 1=Red, 2=Orange, 3=White, 4=Green, 5=Blue, 6=Yellow, 7=No signalling
Signaling switching output: Operating status Flashing	288	0x0120	1	U8	R/W	0 = No, 1 = Yes
Operating states	289	0x0121	1	U8	R/W	Free signalling 1 ... 5
Signaling switching output: failure Red	290	0x0122	1	U8	R/W	0 ... 255
Signaling switching output: failure Green	291	0x0123	1	U8	R/W	0 ... 255

Data	ISDU (dez)	ISDU (hex)	Size (Byte)	Data type	Access	Value range
Signaling switching output: failure Blue	292	0x0124	1	U8	R/W	0 ... 255
Signaling switching output: switching output Red	293	0x0125	1	U8	R/W	0 ... 255
Signaling switching output: switching output Green	294	0x0126	1	U8	R/W	0 ... 255
Signaling switching output: switching output Blue	295	0x0127	1	U8	R/W	0 ... 255
Signaling switching output: operation status Red	296	0x0128	1	U8	R/W	0 ... 255
Signaling switching output: operation status Green	297	0x0129	1	U8	R/W	0 ... 255
Signaling switching output: operation status Blue	298	0x012A	1	U8	R/W	0 ... 255
Free signalling: Colour selection range 1	299	0x012B	1	U8	R/W	0=Individually colour, 1=Red, 2=Orange, 3=White, 4=Green, 5=Blue, 6=Yellow, 7=No signalling
Free signalling: Flashing range 1	300	0x012C	1	U8	R/W	0 = No, 1 = Yes
Free signalling: Upper limit range 1	301	0x012D	4	Float	R/W	0 ... 15000
Free signalling: Colour selection range 2	302	0x012E	1	U8	R/W	0=Individually colour, 1=Red, 2=Orange, 3=White, 4=Green, 5=Blue, 6=Yellow, 7=No signalling
Free signalling: Flashing range 2	303	0x012F	1	U8	R/W	0 = No, 1 = Yes
Free signalling: Upper limit range 2	304	0x0130	4	Float	R/W	0 ... 15000
Free signalling: Colour selection range 3	305	0x0131	1	U8	R/W	0=Individually colour, 1=Red, 2=Orange, 3=White, 4=Green, 5=Blue, 6=Yellow, 7=No signalling
Free signalling: Flashing range 3	306	0x0132	1	U8	R/W	0 = No, 1 = Yes
Free signalling: Upper limit range 3	307	0x0133	4	Float	R/W	0 ... 15000
Free signalling: Colour selection range 4	308	0x0134	1	U8	R/W	0=Individually colour, 1=Red, 2=Orange, 3=White, 4=Green, 5=Blue, 6=Yellow, 7=No signalling
Free signalling: Flashing range 4	309	0x0135	1	U8	R/W	0 = No, 1 = Yes

Data	ISDU (dez)	ISDU (hex)	Size (Byte)	Data type	Access	Value range
Free signalling: Upper limit range 4	310	0x0136	4	Float	R/W	0 ... 15000
Free signalling: Colour selection range 5	311	0x0137	1	U8	R/W	0=Individually colour, 1=Red, 2=Orange, 3=White, 4=Green, 5=Blue, 6=Yellow, 7=No signalling
Free signalling: Flashing range 5	312	0x0138	1	U8	R/W	0 = No, 1 = Yes
Switching output: Range 1 Red	313	0x0139	1	U8	R/W	0 ... 255
Switching output: Range 1 Green	314	0x013A	1	U8	R/W	0 ... 255
Switching output: Range 1 Blue	315	0x013B	1	U8	R/W	0 ... 255
Switching output: Range 2 Red	316	0x013C	1	U8	R/W	0 ... 255
Switching output: Range 2 Green	317	0x013D	1	U8	R/W	0 ... 255
Switching output: Range 2 Blue	318	0x013E	1	U8	R/W	0 ... 255
Switching output: Range 1 Red	319	0x013F	1	U8	R/W	0 ... 255
Switching output: Range 1 Green	320	0x0140	1	U8	R/W	0 ... 255
Switching output: Range 1 Blue	321	0x0141	1	U8	R/W	0 ... 255
Switching output: Range 1 Red	322	0x0142	1	U8	R/W	0 ... 255
Switching output: Range 1 Green	323	0x0143	1	U8	R/W	0 ... 255
Switching output: Range 1 Blue	324	0x0144	1	U8	R/W	0 ... 255
Switching output: Range 1 Red	325	0x0145	1	U8	R/W	0 ... 255
Switching output: Range 1 Green	326	0x0146	1	U8	R/W	0 ... 255
Switching output: Range 1 Blue	327	0x0147	1	U8	R/W	0 ... 255
Lighting (DIS)	328	0x0148	1	U8	R/W	0 = Off, 1 = On

1016153-EN-250813

Data	ISDU (dez)	ISDU (hex)	Size (Byte)	Data type	Access	Value range
Menu language	329	0x0149	1	U8	R/W	49=DE, 44=EN 33=FR, 34=ES, 35=PT, 39=IT, 31=NL, 7=RU, 81=JP, 86 = CN, 90=TR, 42 = CZ, 48= PL
Display value	330	0x014A	1	U8	R/W	0 = distance, 6 = filling height
Integration time	331	0x014B	4	Float	R/W	0 ... 999s
Transistor function	332	0x014C	1	U8	R/W	0=pnp, 1=npn
Function output 2	333	0x014D	1	U8	R/W	0= switching output (SSC1.2) 1= currentoutput (4 ... 20 mA)
Output 1: Switch ON delay (DS1)	334	0x014E	4	Float	R/W	0 ... 60s
Output 1: Reset delay (DR1)	335	0x014F	4	Float	R/W	0 ... 60 s
Output 2: Switching delay (DS2)	336	0x0150	4	Float	R/W	0 ... 60 s
Output 2: Reset delay (DR2)	337	0x0151	4	Float	R/W	0 ... 60 s
Sounded distance to the medium from the antenna edge	338	0x0152	4	Float	R/W	0 ... 15000
Behaviour with echo loss	339	0x0153	1	U8	R/W	0 = last valid measured value 1 = failure message 2 = maintenance message
Time until fault signal	340	0x0154	2	U16	R/W	0 ... 600 s
(1) Activate limitation measuring range begin	341	0x0155	1	U8	R/W	0 = No, 1 = Yes
(2) Manual limitation of the measuring range begin	342	0x0156	4	Float	R/W	0 ... 15000
(5) Averaging factor on increasing amplitude	343	0x0157	1	U8	R/W	0 ... 10
(6) Averaging factor on decreasing amplitude	344	0x0158	1	U8	R/W	0 ... 10
(15) Activate measurement of the "first large echo" function	345	0x0159	1	U8	R/W	0 = No, 1 = Yes
(16) Amplitude difference "First large echo" function	346	0x015A	1	U8	R/W	0 ... 120

Data	ISDU (dez)	ISDU (hex)	Size (Byte)	Data type	Access	Value range
(25) Adjustment in	347	0x015B	1	U8	R/W	0 = distance, 1 = filling height
Distance	348	0x015C	4	Float	R	-
Measurement reliability	349	0x015D	4	Float	R	-
Filling height	350	0x015E	4	Float	R	-
Electronics temperature	351	0x015F	4	Float	R	-
Measure rate	352	0x0160	4	Float	R	-
Switching output 1	353	0x0161	1	U8	R	-
Switching output 2	354	0x0162	1	U8	R	-
Current output	355	0x0163	4	Float	R	-
Device status acc. to NE 107	356	0x0164	1	U8	R	-
Device status	357	0x0165	19	String19	R	-
Detail status	358	0x0166	4	U32	R	-
Counter for change of parameters	359	0x0167	4	U32	R	-
Filling height	360	0x0168	1	U8	R	-
Distance	361	0x0169	1	U8	R	-
Measurement reliability	362	0x016A	1	U8	R	-
Electronics temperature	363	0x016B	1	U8	R	-
Meas. rate	364	0x016C	1	U8	R	-
Switching output 1	365	0x016D	1	U8	R	-
Switching output 2	366	0x016E	1	U8	R	-
Current output	367	0x016F	1	U8	R	-
Function control	368	0x0170	1	U8	R/W	0 = Off, 1 = On
Out of specification	369	0x0171	1	U8	R/W	0 = Off, 1 = On
Maintenance required	370	0x0172	1	U8	R/W	0 = Off, 1 = On
Device name	371	0x0173	19	String19	R	-
Serial number	372	0x0174	16	String16	R	-
Software version	373	0x0175	19	String19	R	-
Hardware version	374	0x0176	19	String19	R	-
Min. distance	375	0x0177	4	Float	R	-
Max. distance	376	0x0178	4	Float	R	-
Minimum filling height	377	0x0179	4	Float	R	-
Maximum filling height	378	0x017A	4	Float	R	-
Min. meas. rate	379	0x017B	4	Float	R	-
Max. meas. rate	380	0x017C	4	Float	R	-

1016153-EN-250813

Data	ISDU (dez)	ISDU (hex)	Size (Byte)	Data type	Access	Value range
Minimum measurement reliability	381	0x017D	4	Float	R	-
Max. measurement reliability	382	0x017E	4	Float	R	-
Min. electronics temperature	383	0x017F	4	Float	R	-
Max. electronics temperature	384	0x0180	4	Float	R	-
Simulation, switching output	385	0x0181	1	U8	R/W	0 = Off, 1 = On
Simulation value	386	0x0182	1	U8	R/W	0 = Open 1 = Closed
Simulation, switching output 2	387	0x0183	1	U8	R/W	0 = Off, 1 = On
Simulation value	388	0x0184	1	U8	R/W	0 = Open 1 = Closed
Simulation, current output	389	0x0185	1	U8	R/W	0 = Off, 1 = On
Simulation value	390	0x0186	4	Float	R/W	3.55 ... 22.0 mA
Simulation, distance	391	0x0187	1	U8	R/W	0 = Off, 1 = On
Simulation value	392	0x0188	4	Float	R/W	0 ... 15000
Simulation, filling height	393	0x0189	1	U8	R/W	0 = Off, 1 = On
Simulation value	394	0x018A	4	Float	R/W	0 ... 15000
Bluetooth communication	397	0x018D	1	U8	R/W	0 = deactivated 1 = activated

System commands

Command	ISDU (dez)	ISDU (hex)	Access
Teach SP1	65	0x00A0	W
Teach SP2	66	0x00A1	W
Application Reset	129	0x00A1	W
Back to Box Reset	131	0x00A2	W
Reset pointer distance	160	0x00A0	W
Reset pointer measurement reliability	161	0x00A1	W
Reset pointer electronics temperature	162	0x00A2	W
Reset pointer meas. rate	163	0x00A3	W
Reset pointer filling height	164	0x00A4	W
Create new false signal suppression	165	0x00A5	W
Extend fals signal suppression	166	0x00A6	W
Delete false signal suppression	167	0x00A7	W
Teach current output min value	168	0x00A8	W
Teach current output max value	169	0x00A9	W

14.3 Dimensions

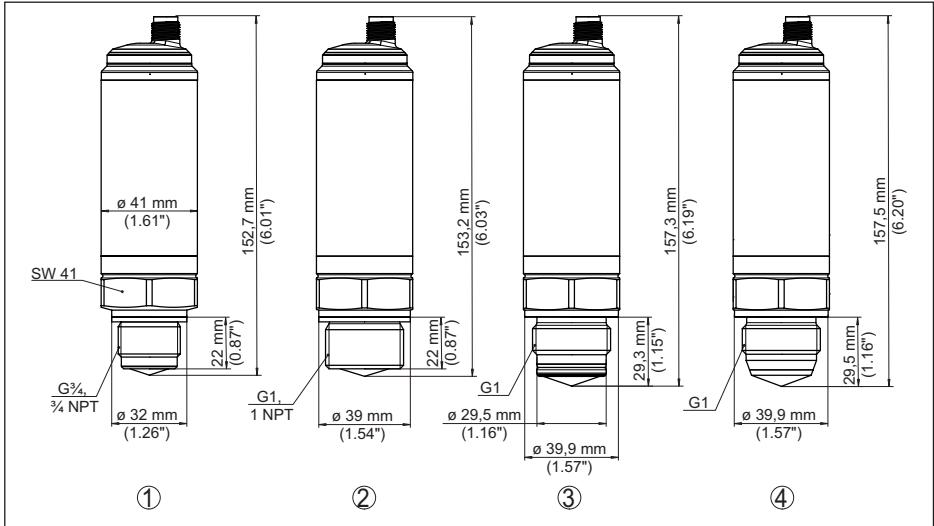

Fig. 29: Dimensions VEGAPULS 42 without display

- 1 Thread G $\frac{3}{4}$
- 2 Thread G1
- 3 Hygienic version thread G1 with O-ring
- 4 Hygienic version thread G1 with cone

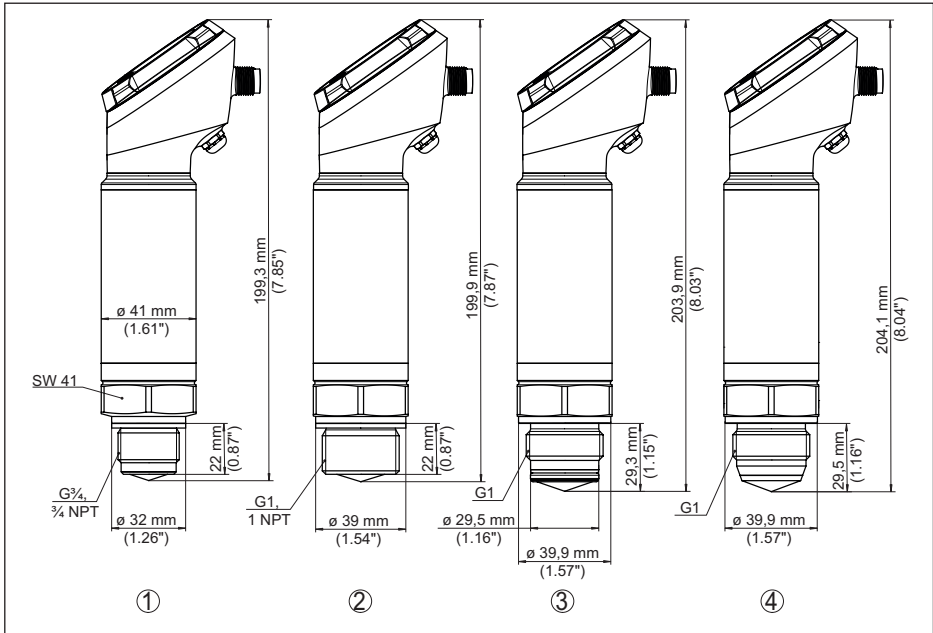

Fig. 30: Dimensions VEGAPULS 42 with display

- 1 Thread G $\frac{3}{4}$
- 2 Thread G1
- 3 Hygienic version thread G1 with O-ring
- 4 Hygienic version thread G1 with cone

14.4 Industrial property rights

VEGA product lines are global protected by industrial property rights. Further information see www.vega.com.

VEGA Produktfamilien sind weltweit geschützt durch gewerbliche Schutzrechte.

Nähere Informationen unter www.vega.com.

Les lignes de produits VEGA sont globalement protégées par des droits de propriété intellectuelle. Pour plus d'informations, on pourra se référer au site www.vega.com.

VEGA lineas de productos están protegidas por los derechos en el campo de la propiedad industrial. Para mayor información revise la pagina web www.vega.com.

Линии продукции фирмы ВЕГА защищаются по всему миру правами на интеллектуальную собственность. Дальнейшую информацию смотрите на сайте www.vega.com.

VEGA系列产品在全球享有知识产权保护。

进一步信息请参见网站www.vega.com。

14.5 Licensing information for open source software

Open source software components are also used in this device. A documentation of these components with the respective license type, the associated license texts, copyright notes and disclaimers can be found on our homepage.

14.6 Trademark

All the brands as well as trade and company names used are property of their lawful proprietor/originator.

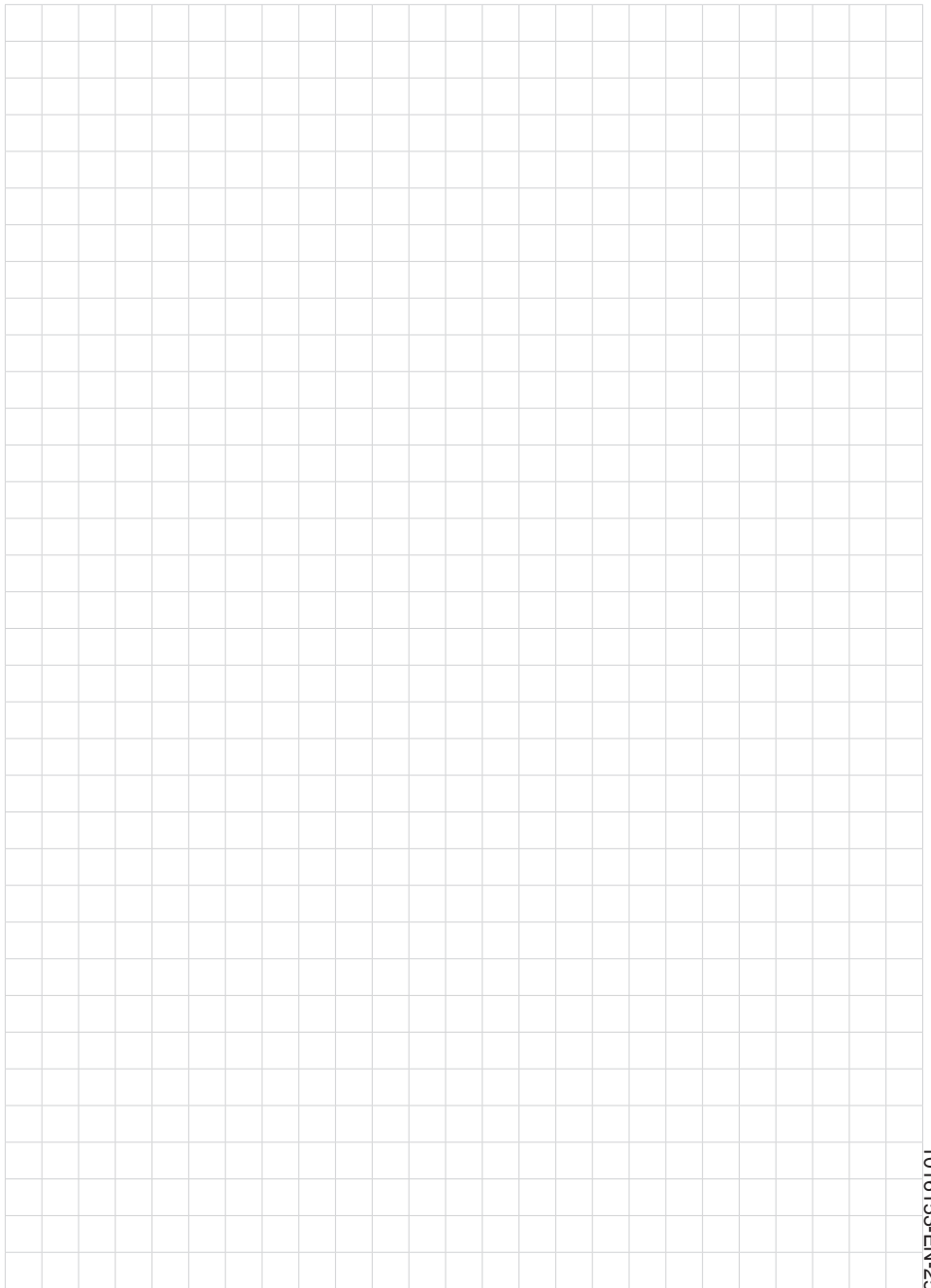

A large grid of graph paper for taking notes, consisting of 20 columns and 30 rows of small squares.

1016153-EN-250813

Printing date:

VEGA

All statements concerning scope of delivery, application, practical use and operating conditions of the sensors and processing systems correspond to the information available at the time of printing.

Subject to change without prior notice

© VEGA Grieshaber KG, Schiltach/Germany 2025

1016153-EN-250813

VEGA Grieshaber KG
Am Hohenstein 113
77761 Schiltach
Germany

Phone +49 7836 50-0
E-mail: info.de@vega.com
www.vega.com