

Operating Instructions

Lock fitting ARV-VB63.2

for VEGAVIB 63

- Pressure range -1 ... 16 bar

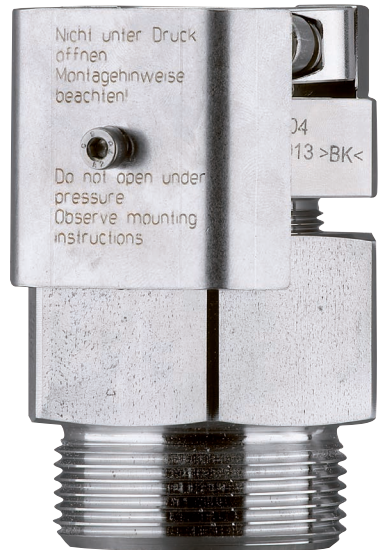

Document ID: 29754



VEGA

Contents

- 1 About this document**
 - 1.1 Function 3
 - 1.2 Target group 3
 - 1.3 Symbols used..... 3
- 2 For your safety**
 - 2.1 Authorised personnel 4
 - 2.2 Appropriate use..... 4
 - 2.3 Warning about incorrect use..... 4
 - 2.4 General safety instructions 4
 - 2.5 Environmental instructions 5
- 3 Product description**
 - 3.1 Configuration..... 6
 - 3.2 Principle of operation..... 6
 - 3.3 Packaging, transport and storage..... 6
- 4 Mounting**
 - 4.1 General instructions 8
 - 4.2 Mounting sequence..... 8
- 5 Maintenance and fault rectification**
 - 5.1 Maintenance 10
 - 5.2 Exchange seals 10
 - 5.3 Instrument repair 11
- 6 Dismount**
 - 6.1 Dismounting steps..... 12
 - 6.2 Disposal 12
- 7 Supplement**
 - 7.1 Technical data 13
 - 7.2 Dimensions 14

1 About this document

1.1 Function

This operating instructions manual provides all the information you need for mounting, connection and setup as well as important instructions for maintenance and fault rectification. Please read this information before putting the instrument into operation and keep this manual accessible in the immediate vicinity of the device.

1.2 Target group

This operating instructions manual is directed to trained specialist personnel. The contents of this manual should be made available to these personnel and put into practice by them.

1.3 Symbols used



Information, tip, note

This symbol indicates helpful additional information.



Caution: If this warning is ignored, faults or malfunctions can result.



Warning: If this warning is ignored, injury to persons and/or serious damage to the instrument can result.



Danger: If this warning is ignored, serious injury to persons and/or destruction of the instrument can result.



Ex applications

This symbol indicates special instructions for Ex applications.



SIL applications

This symbol indicates instructions for functional safety which must be taken into account particularly for safety-relevant applications.

- **List**

The dot set in front indicates a list with no implied sequence.

- **Action**

This arrow indicates a single action.

- 1 **Sequence of actions**

Numbers set in front indicate successive steps in a procedure.



Battery disposal

This symbol indicates special information about the disposal of batteries and accumulators.

2 For your safety

2.1 Authorised personnel

All operations described in this operating instructions manual must be carried out only by trained specialist personnel authorised by the plant operator.

During work on and with the device the required personal protective equipment must always be worn.

2.2 Appropriate use

ARV-VB63.2 is used for for infinite locking with tube extension.

You can find detailed information about the area of application in chapter "*Product description*".

Operational reliability is ensured only if the instrument is properly used according to the specifications in the operating instructions manual as well as possible supplementary instructions.

For safety and warranty reasons, any invasive work on the device beyond that described in the operating instructions manual may be carried out only by personnel authorised by the manufacturer. Arbitrary conversions or modifications are explicitly forbidden.

2.3 Warning about incorrect use

Inappropriate or incorrect use of the instrument can give rise to application-specific hazards, e.g. vessel overfill or damage to system components through incorrect mounting or adjustment.

2.4 General safety instructions

This is a state-of-the-art instrument complying with all prevailing regulations and guidelines. The instrument must only be operated in a technically flawless and reliable condition. The operator is responsible for the trouble-free operation of the instrument.

During the entire duration of use, the user is obliged to determine the compliance of the necessary occupational safety measures with the current valid rules and regulations and also take note of new regulations.

The safety instructions in this operating instructions manual, the national installation standards as well as the valid safety regulations and accident prevention rules must be observed by the user.

For safety and warranty reasons, any invasive work on the device beyond that described in the operating instructions manual may be carried out only by personnel authorised by the manufacturer. Arbitrary conversions or modifications are explicitly forbidden.

The safety approval markings and safety tips on the device must also be observed.

2.5 Environmental instructions

Protection of the environment is one of our most important duties. That is why we have introduced an environment management system with the goal of continuously improving company environmental protection. The environment management system is certified according to DIN EN ISO 14001.

Please help us fulfill this obligation by observing the environmental instructions in this manual:

- Chapter "*Packaging, transport and storage*"
- Chapter "*Disposal*"

3 Product description

3.1 Configuration

Scope of delivery

The scope of delivery encompasses:

- Lock fitting ARV-VB63.2 for VEGAVIB 63 vibrating level switch
- Documentation
 - This operating instructions manual

3.2 Principle of operation

Area of application

ARV-VB63.2 is a pressure-tight threaded fitting up to 16 bar (232 psig) and can be used together with a level sensor in tube version (VEGAVIB 63). The tube version of the sensor must have a diameter of 29 mm (ø 1.14 in).

The sensor in tube version must have a min. length (L) of 265 mm (10.43 in).

The wetted parts of ARV-VB63.2 are made of steel (316L).

Functional principle

With the lock fittings, sensors with tube extension can be fixed infinitely.

The pressure screw of the lock fitting compresses a graphite gasket consisting of three rings axially which is then pressed radially to the tube of the sensor. If mounted correctly, the graphite gasket encircles the tube tightly. The clamp protects the tube against sliding through. A locking bracket protects the terminal screws of the clamp against unauthorised or unintentional loosening.

3.3 Packaging, transport and storage

Packaging

Your instrument was protected by packaging during transport. Its capacity to handle normal loads during transport is assured by a test based on ISO 4180.

The packaging of standard instruments consists of environment-friendly, recyclable cardboard. For special versions, PE foam or PE foil is also used. Dispose of the packaging material via specialised recycling companies.

Transport

Transport must be carried out in due consideration of the notes on the transport packaging. Nonobservance of these instructions can cause damage to the device.

Transport inspection

The delivery must be checked for completeness and possible transit damage immediately at receipt. Ascertained transit damage or concealed defects must be appropriately dealt with.

Storage

Up to the time of installation, the packages must be left closed and stored according to the orientation and storage markings on the outside.

Unless otherwise indicated, the packages must be stored only under the following conditions:

Storage and transport temperature

- Not in the open
- Dry and dust free
- Not exposed to corrosive media
- Protected against solar radiation
- Avoiding mechanical shock and vibration
- Storage and transport temperature see chapter "*Supplement - Technical data - Ambient conditions*"
- Relative humidity 20 ... 85 %

4 Mounting

4.1 General instructions

The note of the following general safety instructions:

- Dismount the lock fitting only in unpressurized condition
- Use only suitable graphite gasket rings (article no. 2.29947). Make sure that the graphite gasket rings are not damaged. Damaged rings are no longer tight. If you are not sure, use new rings.
- Only use approved hexagon screws DIN 912 M6 x 25 of A4-70 according to AD leaflet W2. The corresponding spring rings B6 must be made of A4 according to DIN 7980.
- Grease the thread and the support of the terminal screws with a suitable lubricant. The lubricant must be suitable for material combination 316L/316L and for a temperature range of -50 ... +250°C (-58 ... +482°F) e.g. Varybond type NSS-16/7. The threads are already supplied with a lubricant.

4.2 Mounting sequence

The lock fitting is already premounted.

The figures in brackets refer to the following illustration.

1. Loosen the screw (6) and remove the locking bracket (4)
2. Screw mounting boss (7) with a resistant seal ring into the thread of the vessel and tighten the mounting boss (7) on the hexagon (SW 55)
3. Clean the connection tube of the sensor and the surfaces of the clamp (1) as well as the pressure screw (11) carefully and remove grease, oil and dirt. Insert the sensor into the lock fitting. Slide the tube into the requested position and hold it
4. Make sure that the sensor is in the correct position (height). The height adjustment of the sensor determines also the switching point
5. Tighten the pressure screw (11) with a torque 128 ± 10 Nm (94 ± 7 lbf ft)
6. Continue to turn the pressure screw (11) clockwise until the hexagon surfaces of the pressure screw (11) and the mounting boss (7) correspond (max. 1/6 turn)
7. Tighten the terminal screws (3) alternately. Make sure that the gap between clamp and pressure screw is in parallel. Tighten the terminal screws up to a torque of 4 ± 1 Nm (3 ± 0.7 lbf ft).
Hence the clamp (1) is pressed against the tube and fixes the tube of the sensor in this position
8. Fasten the locking angle (4) with the hold screw (6) and the spring ring (5) laterally on the pressure screw (11)
Hence the pressure screw and the terminal screw are secured against unintentional loosening

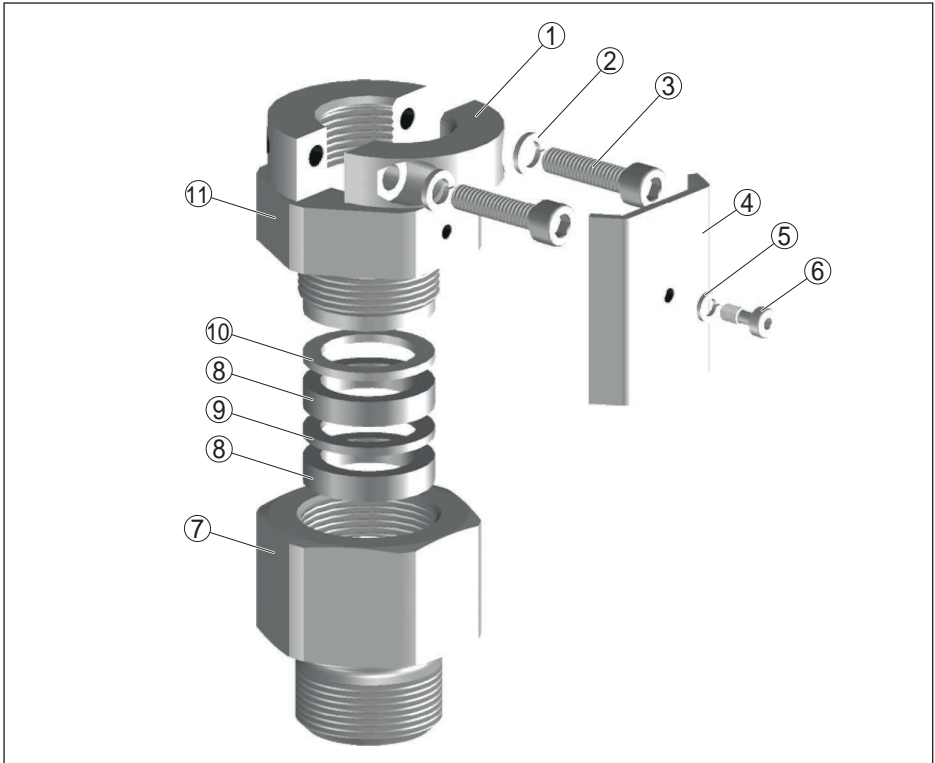

Fig. 1: Lock fitting ARV-VB63.2 - up to 16 bar (232 psig)

- 1 Clamp
- 2 Spring ring B6
- 3 Terminal screw M6 x 25
- 4 Locking angle
- 5 Spring ring B4
- 6 Holding screw M4 x 10
- 7 Mounting boss
- 8 Gasket ring (article no. 2.29947)
- 9 Graphite gasket ring (article no. 2.29947)
- 10 Pressure ring
- 11 Pressure screw

5 Maintenance and fault rectification

5.1 Maintenance

If the instrument is used properly, no special maintenance is required in normal operation.

5.2 Exchange seals

If you want to loosen the lock fitting, e.g. to change the switching point, you have to exchange the graphite gasket rings.

The numbers in brackets refer to the illustration under "Mounting".



Danger:

Before dismounting, make sure that the vessel is unpressurised

1. Loosen the screw (6) and remove the locking bracket (4)
2. Loosen pressure screw (11)
3. Hold the tube of the sensor and loosen the terminal screws (3)
4. Pull the sensor out of the lock fitting
5. Unscrew the pressure screw (11) out of the mounting boss (7)
6. Screw mounting boss (7) with a new resistant seal ring into the thread of the vessel and tighten the mounting boss (7) on the hexagon (SW 55)
7. Unpack the new gasket and graphite gasket rings. The graphite gasket ring (9) is thin; the gasket rings (8) are a little thicker and have a layer configuration.
Make sure that the rings are not damages. If you are not sure, use new rings (article no. 2.29947)
8. First of all place one of the new gasket rings (8) into the mounting boss (7). Then place the graphite gasket ring (9) on top. This is followed by the second gasket ring (8)
9. Place the pressure ring (10) of metal to the gasket rings
10. Screw the pressure screw (11) with a view turns from top into the mounting boss (7)
11. Clean the connection tube of the sensor and the surfaces of the clamp (1) as well as the pressure screw (11) carefully and remove grease, oil and dirt. Insert the sensor into the lock fitting. Slide the tube into the requested position and hold it
12. Make sure that the sensor is in the correct position (height). The height adjustment of the sensor determines also the switching point
13. Tighten the pressure screw (11) with a torque 128 ± 10 Nm (94 ± 7 lbf ft)
14. Continue to turn the pressure screw (11) clockwise until the hexagon surfaces of the pressure screw (11) and the mounting boss (7) correspond (max. 1/6 turn)

15. Tighten the terminal screws (3) alternately. Make sure that the gap between clamp and pressure screw is in parallel. Tighten the terminal screws up to a torque of 4 ± 1 Nm (3 ± 0.7 lbf ft).
Hence the clamp (1) is pressed against the tube and fixes the tube of the sensor in this position
16. Fasten the locking angle (4) with the hold screw (6) and the spring ring (5) laterally on the pressure screw (11)
Hence the pressure screw and the terminal screw are secured against unintentional loosening

5.3 Instrument repair

If it is necessary to repair the instrument, please contact the agency serving you.

6 Dismount

6.1 Dismounting steps

Note chapter "*Mounting*" and carry out the described steps in reverse order.



Warning:

If you want to remove the lock fitting for service or control purposes, make sure that the vessel is unpressurised.

If you proceed as follows, it is not necessary to readjust the switching point and the lock fittings must not be dismantled completely.

1. Switch off power supply of the sensor
2. Remove all connection cables
3. Loosen the mounting boss with a screwdriver
4. Remove the sensor together with the lock fitting

6.2 Disposal

The instrument consists of materials which can be recycled by specialised recycling companies. Mark the instrument as scrap and dispose it according to the national, legal regulations.

Materials: see chapter "*Technical data*"

If you have no way to dispose of the old instrument properly, please contact us concerning return and disposal.

7 Supplement

7.1 Technical data

General data

Material 316L corresponds to 1.4404 or 1.4435

Process fittings

- Pipe thread, cylindrical (DIN 3852-A) G1½, G2
- American pipe thread, conical (ASME B1.20.1) 1½ NPT, 2 NPT

Tube diameter of the sensor ø 29 mm (1.14 in) according to DIN 2463/2462 D4-T3

Min. length of the sensor 290 mm (11.42 in)

Materials

- Lock fitting 316L, Alloy C22 (2.4602)
- Graphite packing rings Graphite
- Process seal Klingersil C-4400¹⁾

Terminal screws

Hexagon screws DIN 912 M6 x 25 material A4-70 according to AD leaflet W2; corresponding spring rings B6 materials A4 according to DIN 7980

Holding screw

Hexagon screw DIN 7964 M4 x 10 material A4-70; corresponding spring ring B4 material A4 according to DIN 7980

Torques

- Terminal screws 4 ±1 Nm (3 ±0.7 lbf ft)
- Pressure screw 128 ±10 Nm (94 ±7 lbf ft)

Process conditions

Operating pressure 16 bar (232 psig)

Take note of the nominal pressure of the sensor. The lower permissible operating pressure is valid.

Process temperature

-50 ... +150 °C (-58 ... +302 °F)

Approvals²⁾

In conjunction with a corresponding point level sensor, ARV-VB63.2 has the following approvals.

- | | |
|---------|--|
| ATEX ia | ATEX II 1G, 1/2G, 2G EEx ia IIC T6 ³⁾ |
| ATEX d | ATEX II 1/2G, 2G EEx d IIC T6 |
| ATEX | ATEX II 1/2D IP66 T |

¹⁾ Not with thread NPT.

²⁾ Take note of the corresponding certificates of the sensor.

³⁾ Only in conjunction with electronics "Z".

7.2 Dimensions

Lock fitting ARV-VB63.2 for VEGAVIB 63

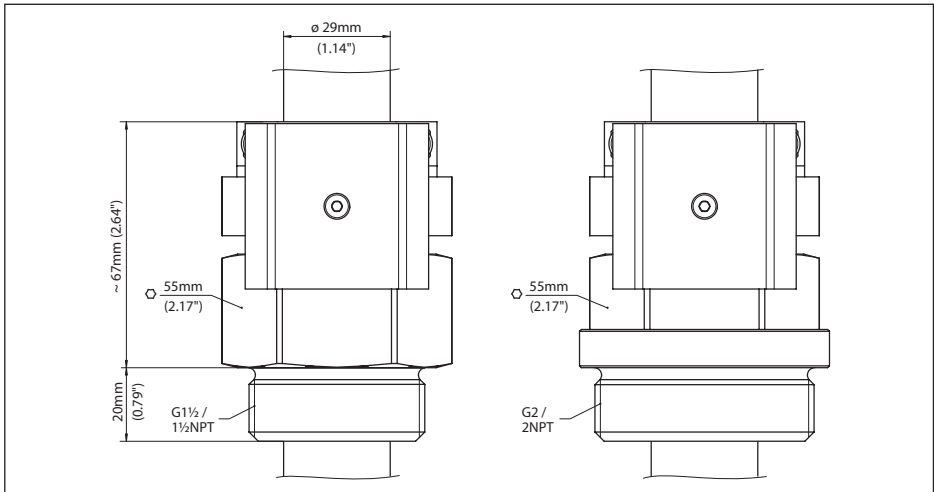

Fig. 2: Lock fitting ARV-VB63.2 up to 16 bar (232 psig) for VEGAVIB 63



Printing date:

VEGA

All statements concerning scope of delivery, application, practical use and operating conditions of the sensors and processing systems correspond to the information available at the time of printing.

Subject to change without prior notice

© VEGA Grieshaber KG, Schiltach/Germany 2015



29754-EN-150908

VEGA Grieshaber KG
Am Hohenstein 113
77761 Schiltach
Germany

Phone +49 7836 50-0
Fax +49 7836 50-201
E-mail: info.de@vega.com
www.vega.com