

Operating Instructions

Conductive rod electrode

Conductive probe EL 8



Document ID: 32655



VEGA

Contents

1	About this document	3
1.1	Function	3
1.2	Target group	3
1.3	Symbols used.....	3
2	For your safety	4
2.1	Authorised personnel	4
2.2	Appropriate use.....	4
2.3	Warning about incorrect use.....	4
2.4	General safety instructions	4
2.5	Installation and operation in the USA and Canada	5
2.6	Safety instructions for Ex areas	5
2.7	Environmental instructions	5
3	Product description	6
3.1	Configuration.....	6
3.2	Principle of operation.....	7
3.3	Adjustment	7
3.4	Packaging, transport and storage.....	7
4	Mounting	9
4.1	General instructions	9
4.2	Mounting instructions	9
5	Connecting to power supply	11
5.1	Preparing the connection	11
5.2	Wiring plan	11
6	Setup	13
6.1	General information.....	13
7	Maintenance and fault rectification	14
7.1	Maintenance	14
7.2	Rectify faults.....	14
7.3	Shortening the probe.....	14
7.4	How to proceed if a repair is necessary.....	14
8	Dismount	16
8.1	Dismounting steps.....	16
8.2	Disposal	16
9	Supplement	17
9.1	Technical data	17
9.2	Dimensions	18
9.3	Industrial property rights.....	19

1 About this document

1.1 Function

This instruction provides all the information you need for mounting, connection and setup as well as important instructions for maintenance, fault rectification, the exchange of parts and the safety of the user. Please read this information before putting the instrument into operation and keep this manual accessible in the immediate vicinity of the device.

1.2 Target group

This operating instructions manual is directed to trained personnel. The contents of this manual must be made available to the qualified personnel and implemented.

1.3 Symbols used



Document ID

This symbol on the front page of this instruction refers to the Document ID. By entering the Document ID on www.vega.com you will reach the document download.



Information, note, tip: This symbol indicates helpful additional information and tips for successful work.



Note: This symbol indicates notes to prevent failures, malfunctions, damage to devices or plants.



Caution: Non-observance of the information marked with this symbol may result in personal injury.



Warning: Non-observance of the information marked with this symbol may result in serious or fatal personal injury.



Danger: Non-observance of the information marked with this symbol results in serious or fatal personal injury.



Ex applications

This symbol indicates special instructions for Ex applications.



List

The dot set in front indicates a list with no implied sequence.



Sequence of actions

Numbers set in front indicate successive steps in a procedure.



Disposal

This symbol indicates special instructions for disposal.

2 For your safety

2.1 Authorised personnel

All operations described in this documentation must be carried out only by trained, qualified personnel authorised by the plant operator.

During work on and with the device, the required personal protective equipment must always be worn.

2.2 Appropriate use

The EL 8 is a sensor for point level detection.

You can find detailed information about the area of application in chapter " *Product description*".

Operational reliability is ensured only if the instrument is properly used according to the specifications in the operating instructions manual as well as possible supplementary instructions.

For safety and warranty reasons, any invasive work on the device beyond that described in the operating instructions manual may be carried out only by personnel authorised by the manufacturer. Arbitrary conversions or modifications are explicitly forbidden.

2.3 Warning about incorrect use

Inappropriate or incorrect use of this product can give rise to application-specific hazards, e.g. vessel overflow through incorrect mounting or adjustment. Damage to property and persons or environmental contamination can result. Also, the protective characteristics of the instrument can be impaired.

2.4 General safety instructions

This is a state-of-the-art instrument complying with all prevailing regulations and directives. The instrument must only be operated in a technically flawless and reliable condition. The operator is responsible for the trouble-free operation of the instrument. When measuring aggressive or corrosive media that can cause a dangerous situation if the instrument malfunctions, the operator has to implement suitable measures to make sure the instrument is functioning properly.

The safety instructions in this operating instructions manual, the national installation standards as well as the valid safety regulations and accident prevention rules must be observed by the user.

For safety and warranty reasons, any invasive work on the device beyond that described in the operating instructions manual may be carried out only by personnel authorised by the manufacturer. Arbitrary conversions or modifications are explicitly forbidden. For safety reasons, only the accessory specified by the manufacturer must be used.

To avoid any danger, the safety approval markings and safety tips on the device must also be observed.

2.5 Installation and operation in the USA and Canada

This information is only valid for USA and Canada. Hence the following text is only available in the English language.

Installations in the US shall comply with the relevant requirements of the National Electrical Code (ANSI/NFPA 70).

Installations in Canada shall comply with the relevant requirements of the Canadian Electrical Code.

2.6 Safety instructions for Ex areas

For applications in explosion-proof areas (Ex), only devices with corresponding Ex approval may be used. Observe the Ex-specific safety instructions. These are an integral part of the operating instructions and are enclosed with every device with Ex approval.

2.7 Environmental instructions

Protection of the environment is one of our most important duties. That is why we have introduced an environment management system with the goal of continuously improving company environmental protection. The environment management system is certified according to DIN EN ISO 14001.

Please help us fulfil this obligation by observing the environmental instructions in this manual:

- Chapter " *Packaging, transport and storage* "
- Chapter " *Disposal* "

3 Product description

3.1 Configuration

Scope of delivery

The scope of delivery encompasses:

- EL 8 point level switch
- Documentation
 - This operating instructions manual

Constituent parts

The EL 8 consists of the components:

- Housing
- Process fitting with electrode

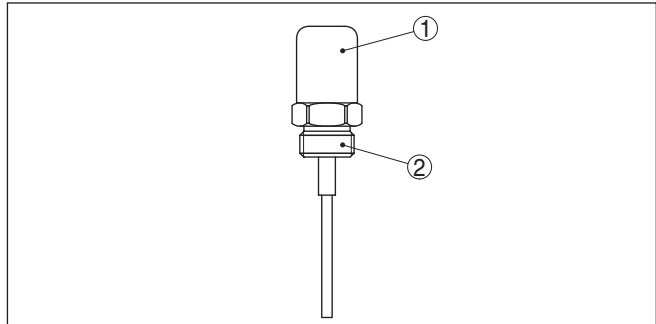

Fig. 1: Conductive rod electrode EL 8

- 1 Housing
- 2 Process fitting

To create a measuring system you need one conductive probe and a VEGATOR 131 or 132 controller

Serial number - Instrument search

The type label contains the serial number of the instrument. With it you can find the following instrument data on our homepage:

- Product code (HTML)
- Delivery date (HTML)
- Order-specific instrument features (HTML)
- Operating instructions and quick setup guide at the time of shipment (PDF)
- Order-specific sensor data

Move to "www.vega.com" and enter in the search field the serial number of your instrument.

Alternatively, you can access the data via your smartphone:

- Download the VEGA Tools app from the "*Apple App Store*" or the "*Google Play Store*"
- Scan the DataMatrix code on the type label of the instrument or
- Enter the serial number manually in the app

Area of application	3.2 Principle of operation <p>EL 8 is a point level sensor with partly insulated conductive electrode for level detection.</p> <p>EL 8 is very rugged and can be used in all areas of industrial process technology.</p> <p>The level switch can be used in conductive liquids such as e.g. water. Typical applications are overflow and dry run protection.</p> <p>The conductive measuring principle places no special requirements on installation. Hence, many different applications can be equipped with EL 8.</p>
Functional principle	<p>Conductive probes detect the product resistance when their electrodes are covered by the product.</p> <p>The switching signal is determined by the length or mounting position of the respective electrode.</p> <p>A low alternating current flows through the electrodes, is measured for amplitude and phase position by the electronics of the controller and converted into a switching command.</p>
Voltage supply	<p>EL 8 is operated with an external processing unit. The connected controller powers EL 8 and provides a switching signal. A connected device can be activated directly with this switching command (e.g. a warning system, a PLC, a pump, etc.).</p> <p>You can find the exact range of the voltage supply in chapter " <i>Technical data</i>" in the operating instructions manual of the controller.</p>
Packaging	3.3 Adjustment <p>The probe does not have its own electronics. The measurement is carried out via the connected controller.</p> 3.4 Packaging, transport and storage <p>Your instrument was protected by packaging during transport. Its capacity to handle normal loads during transport is assured by a test based on ISO 4180.</p> <p>The packaging of standard instruments consists of environment-friendly, recyclable cardboard. For special versions, PE foam or PE foil is also used. Dispose of the packaging material via specialised recycling companies.</p>
Transport	<p>Transport must be carried out in due consideration of the notes on the transport packaging. Nonobservance of these instructions can cause damage to the device.</p>
Transport inspection	<p>The delivery must be checked for completeness and possible transit damage immediately at receipt. Ascertained transit damage or concealed defects must be appropriately dealt with.</p>

Storage

Up to the time of installation, the packages must be left closed and stored according to the orientation and storage markings on the outside.

Unless otherwise indicated, the packages must be stored only under the following conditions:

- Not in the open
- Dry and dust free
- Not exposed to corrosive media
- Protected against solar radiation
- Avoiding mechanical shock and vibration

Storage and transport temperature

- Storage and transport temperature see chapter " *Supplement - Technical data - Ambient conditions*"
- Relative humidity 20 ... 85 %

Lifting and carrying

With instrument weights of more than 18 kg (39.68 lbs) suitable and approved equipment must be used for lifting and carrying.

4 Mounting

4.1 General instructions

Switching point	In general the level switch can be mounted in any position. The instrument must be mounted in such a way that the probe is at the height of the requested switching point.
Handling	<p>The probe is provided with a special hexagon for tightening. Due to the hexagon shape, the housing itself can be used to screw the instrument in.</p> <p>The wrench size is stated in chapter " <i>Supplement</i>" under " <i>Dimensions</i>".</p>
Moisture	<p>Use the recommended cables (see chapter " <i>Connecting to voltage supply</i>") and keep the opening for the cable as small as possible.</p> <p>You can give your EL 8 additional protection against moisture penetration by leading the connection cable downward in front of the cable gland. Rain and condensation water can thus drain off. This applies mainly to outdoor mounting as well as installation in areas where high humidity is expected (e.g. through cleaning processes) or on cooled or heated vessels.</p>
Transport	Do not hold EL 8 on its electrode rods. Particularly with long rod versions, the sensor can be damaged by the weight of the instrument.
Pressure/Vacuum	<p>The process fitting must be sealed if there is gauge or low pressure in the vessel. Before use, check if the sealing material is resistant against the measured product and the process temperature.</p> <p>The max. permissible pressure is specified in chapter " <i>Technical data</i>" or on the type label of the sensor.</p>

4.2 Mounting instructions

Agitators and fluidization	<p>Due to agitators, equipment vibration or similar, the level switch can be subjected to strong lateral forces.</p> <p>Extreme vibration caused by the system, e.g. due to agitators or turbulence in the vessel from fluidisation, can cause the probe of EL 8 to vibrate in resonance. If a longer rod version is necessary, you can secure the probe by fastening a suitable isolated brace or guy directly above the end of the rod.</p>
-----------------------------------	---

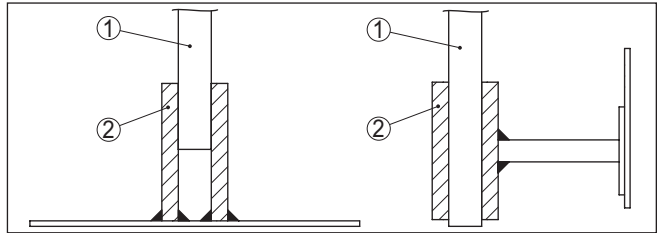

Fig. 2: Fasten the probe

- 1 Measuring probe
- 2 Plastic sleeve at the probe end or laterally mounted

Inflowing medium

If EL 8 is mounted in the filling stream, unwanted false measurement signals can be generated. For this reason, mount EL 8 at a position in the vessel where no disturbances, e.g. from filling openings, agitators, etc., can occur.

This applies particularly to instrument versions with a longer probe.

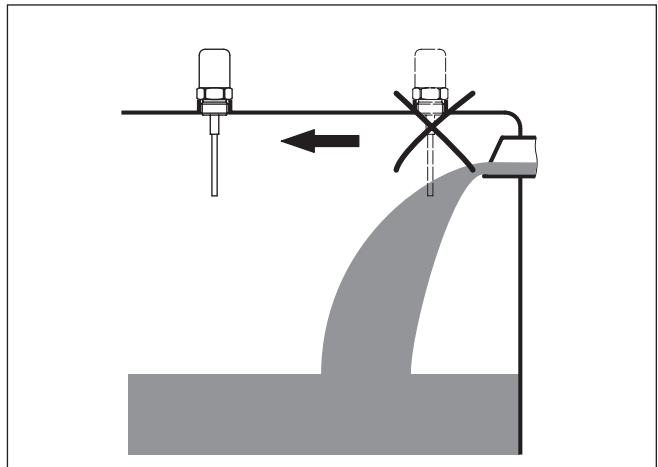

Fig. 3: Inflowing medium

Nozzle

The probe should protrude into the vessel to avoid buildup. For that reason, avoid using high mounting bosses for screw-in fittings. This applies particularly to use in adhesive products.

Ground connection

Make sure that the mechanical connection of the probe to the vessel is electrically conductive to ensure sufficient grounding.

Use conductive seals, such as those made of copper or lead, etc. Insulating measures, such as covering the thread with Teflon tape, can interrupt the necessary electrical connection with metal vessels. For this reason, ground the probe on the vessel or use a conductive seal material.

5 Connecting to power supply

5.1 Preparing the connection

Note safety instructions

Always keep in mind the following safety instructions:



Warning:

Connect only in the complete absence of line voltage.

- The electrical connection must only be carried out by trained, qualified personnel authorised by the plant operator.
- Always switch off power supply, before connecting or disconnecting the instrument.

Voltage supply

You can find the electrical connection of EL 8 in the operating instructions manual of the corresponding controller.

You can find suitable controllers in chapter " *Technical data*".

Connection cable

To ensure the seal effect of the rubber cover, the instrument is connected with standard cable with round cross-section.

Make sure that the cable used has the required temperature resistance and fire safety for max. occurring ambient temperature

Push cable through

Remove the black rubber cover and punch a small hole in the upper side of the rubber cover with a sharp tool (e.g. a ball pen).



Note:

Do not use a knife or similar for puncturing

Push the connection cable through this opening.

5.2 Wiring plan

Ground connection

The ground connection of the controller must be on the same electrical potential of the conductive vessel.

The EL 8 can be equipped optionally with a grounding eye. Connect the ground cable according to the following illustration.

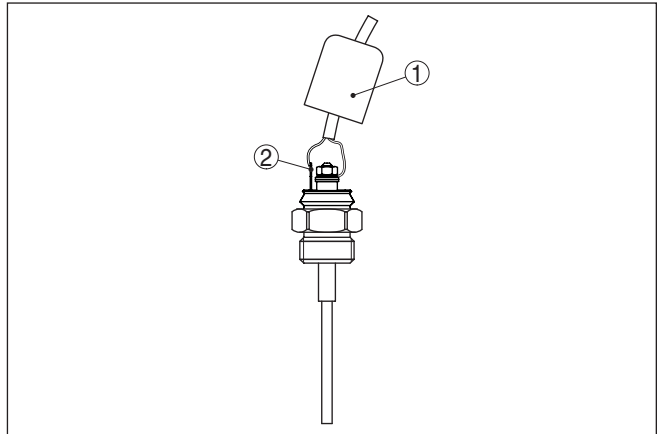

Fig. 4: Ground connection (optional)

- 1 Rubber cap
- 2 Grounding eye

Connection compartment You can find the electrical connection of EL 8 in the operating instructions manual of the corresponding controller.

6 Setup

6.1 General information

You can find the setup procedure for EL 8 in the operating instructions manual of the corresponding controller.

7 Maintenance and fault rectification

7.1 Maintenance

Maintenance

If the device is used properly, no special maintenance is required in normal operation.

Cleaning

The cleaning helps that the type label and markings on the instrument are visible.

Take note of the following:

- Use only cleaning agents which do not corrode the housings, type label and seals
- Use only cleaning methods corresponding to the housing protection rating

7.2 Rectify faults

Causes of malfunction

The device offers maximum reliability. Nevertheless, faults can occur during operation. These may be caused by the following, e.g.:

- Sensor
- Process
- Voltage supply
- Signal processing

Fault rectification

You can find information on fault rectification in the operating instructions manual of the corresponding controller.

24 hour service hotline

Should these measures not be successful, please call in urgent cases the VEGA service hotline under the phone no. **+49 1805 858550**.

The hotline is manned 7 days a week round-the-clock. Since we offer this service worldwide, the support is only available in the English language. The service is free, only standard call charges are incurred.

7.3 Shortening the probe

The probe can be shortened by any amount.

Remove the insulation on a length of approx. 20 mm on the tip of the probe. Hence the probe can detect the switching point in an optimum way.

7.4 How to proceed if a repair is necessary

You can find an instrument return form as well as detailed information about the procedure in the download area of our homepage. By doing this you help us carry out the repair quickly and without having to call back for needed information.

In case of repair, proceed as follows:

- Print and fill out one form per instrument
- Clean the instrument and pack it damage-proof
- Attach the completed form and, if need be, also a safety data sheet outside on the packaging

- Ask the agency serving you to get the address for the return shipment. You can find the agency on our homepage.

8 Dismount

8.1 Dismounting steps

**Warning:**

Before dismounting, be aware of dangerous process conditions such as e.g. pressure in the vessel, high temperatures, corrosive or toxic products etc.

Take note of chapters "*Mounting*" and "*Connecting to voltage supply*" and carry out the listed steps in reverse order.

8.2 Disposal



Pass the instrument on to a specialised recycling company and do not use the municipal collecting points.

Remove any batteries in advance, if they can be removed from the device, and dispose of them separately.

If personal data is stored on the old device to be disposed of, delete it before disposal.

If you have no way to dispose of the old instrument properly, please contact us concerning return and disposal.

9 Supplement

9.1 Technical data

Note for approved instruments

The technical data in the respective safety instructions which are included in delivery are valid for approved instruments (e.g. with Ex approval). These data can differ from the data listed herein, for example regarding the process conditions or the voltage supply.

All approval documents can be downloaded from our homepage.

General data

Materials 316Ti corresponds to 1.4571, 316L corresponds to 1.4404 or 1.4435

Materials, wetted parts

– Process fitting	1.4301
– Process seal	Klingsil C-4400
– Insulation (partly insulated)	PE
– Electrode (rod partly PE insulated: ø 4 mm/0.157 in)	316Ti

Materials, non-wetted parts

– Housing	EPDM
– Cable gland	PA, stainless steel, brass
– Sealing, cable gland	NBR
– Blind plug, cable gland	PA

Process fitting G½ (DIN 3852-A)

Weight

– with basic weight	100 g (3.5 oz)
– Rod weight: ø 4 mm (0.157 in)	100 g/m (1.1 oz/ft)
Sensor length (L)	0.03 ... 1 m (0.1 ... 3.3 ft)

Insulation length 27 mm (1.06 in)

Output variable

Suitable controllers VEGATOR 131, 132

Ambient conditions

Ambient temperature on the housing	-40 ... +80 °C (-40 ... +176 °F)
Storage and transport temperature	-40 ... +80 °C (-40 ... +176 °F)

Process conditions

Process pressure	-1 ... 6 bar/-100 ... 600 kPa (-14.5 ... 87 psig)
Process temperature EL 8 of 316L	-10 ... +60 °C (+14 ... +140 °F)
Conductance of the medium	min. 7.5 µS/cm

Electrical protective measures

Protection rating IP50 (NEMA Type 1)

9.2 Dimensions

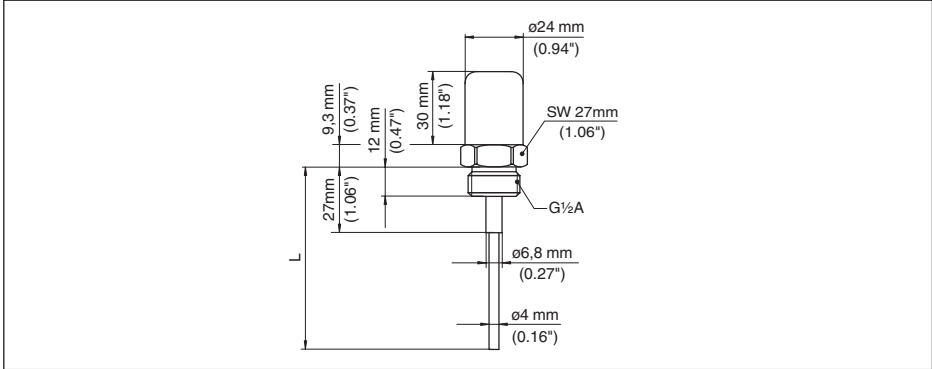

Fig. 5: Conductive rod electrode EL 8

L Sensor length, see chapter "Technical data"

9.3 Industrial property rights

VEGA product lines are global protected by industrial property rights. Further information see www.vega.com.

Only in U.S.A.: Further information see patent label at the sensor housing.

VEGA Produktfamilien sind weltweit geschützt durch gewerbliche Schutzrechte.

Nähere Informationen unter www.vega.com.

Les lignes de produits VEGA sont globalement protégées par des droits de propriété intellectuelle. Pour plus d'informations, on pourra se référer au site www.vega.com.

VEGA líneas de productos están protegidas por los derechos en el campo de la propiedad industrial. Para mayor información revise la pagina web www.vega.com.

Линии продукции фирмы ВЕГА защищаются по всему миру правами на интеллектуальную собственность. Дальнейшую информацию смотрите на сайте www.vega.com.

VEGA系列产品在全球享有知识产权保护。

进一步信息请参见网站 < www.vega.com。

9.4 Trademark

All the brands as well as trade and company names used are property of their lawful proprietor/originator.

Printing date:

VEGA

All statements concerning scope of delivery, application, practical use and operating conditions of the sensors and processing systems correspond to the information available at the time of printing.

Subject to change without prior notice

© VEGA Grieshaber KG, Schiltach/Germany 2022



32655-EN-220324

VEGA Grieshaber KG
Am Hohenstein 113
77761 Schiltach
Germany

Phone +49 7836 50-0
E-mail: info.de@vega.com
www.vega.com