

## Supplementary instructions

### Connection cable IP 66/IP 68 (1 bar)

Retrofitting set/accessory for instruments of  
the plics® family



Document ID: 34107



**VEGA**

## Contents

<b>1 For your safety .....</b>	<b>3</b>
1.1 Appropriate use.....	3
1.2 Impermissible use .....	3
1.3 General safety instructions .....	3
1.4 Safety instructions for Ex areas .....	3
<b>2 Product description .....</b>	<b>4</b>
<b>3 Mounting .....</b>	<b>5</b>
3.1 Mounting preparations .....	5
3.2 Installation procedure .....	5
<b>4 Connecting .....</b>	<b>7</b>
4.1 Preparing the connection .....	7
4.2 Wiring plan, supply cable (cable gland, single-sided).....	7
4.3 Wiring plan, display and adjustment cable (cable gland, double-sided) .....	9
<b>5 Supplement .....</b>	<b>11</b>
5.1 Technical data .....	11
5.2 Dimensions .....	11

## 1 For your safety

### 1.1 Appropriate use

The connection cable is used to retrofit existing plics sensors to achieve protection IP 66/IP 68 (1 bar).

### 1.2 Impermissible use

As a rule, the connection cable is not allowed to be used with four-wire instruments. Four-wire instruments are sensors for direct mains connection whose power supply and measurement signal are transmitted over two separate pairs of wires.

### 1.3 General safety instructions

The safety information in the operating instructions manual of the respective sensor must be noted.

### 1.4 Safety instructions for Ex areas

Please note the Ex-specific safety information for installation and operation in Ex areas. These safety instructions are part of the operating instructions manual and come with the Ex-approved instruments.

For instruments with Ex-d or StEx approval, the use of this connection cable is not allowed.

## 2 Product description

### Scope of delivery

The scope of delivery encompasses:

- Connection cable with cable gland
- Blind plug
- Documentation
  - This operating instructions manual

### Area of application

The connection cable is suitable for the following instruments with aluminium or stainless steel housing:

- VEGAPULS series 60
- VEGAFLEX series 60 and 80
- VEGASON series 60
- VEGACAL series 60
- VEGABAR series 80
- VEGACAP series 60
- VEGASWING series 60
- VEGAWAVE series 60
- VEGADIS 61 and 81

To carry out the retrofit, the existing cable gland is removed and replaced by the cable gland of the connection cable. The filter element in the electronics housing is replaced by the blind plug.

With VEGABAR series 80, the measuring cell is then ventilated after modification via the capillaries in the connection cable.

## 3 Mounting

### 3.1 Mounting preparations

#### Tools

The following tools are required for mounting:

- Spanner SW 24 for unscrewing the cable gland
- Spanner SW 9 for unscrewing the filter element
- Screwdriver size 4 for screwing in the blind plug

#### Blind plug

The blind plug consists of adapter, O-ring and closing screw. It is assembled according to the following drawing:

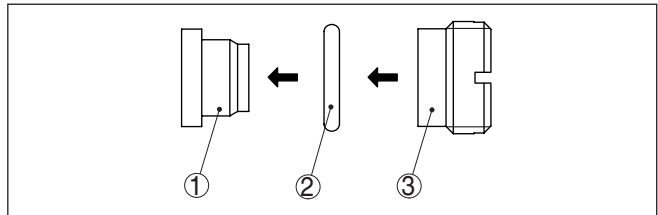

Fig. 1: Assembly of blind plug

- 1 Adapter
- 2 O-ring
- 3 Screw plug

### 3.2 Installation procedure

The illustration below shows the position of the cable gland and the filter element in the respective housing:

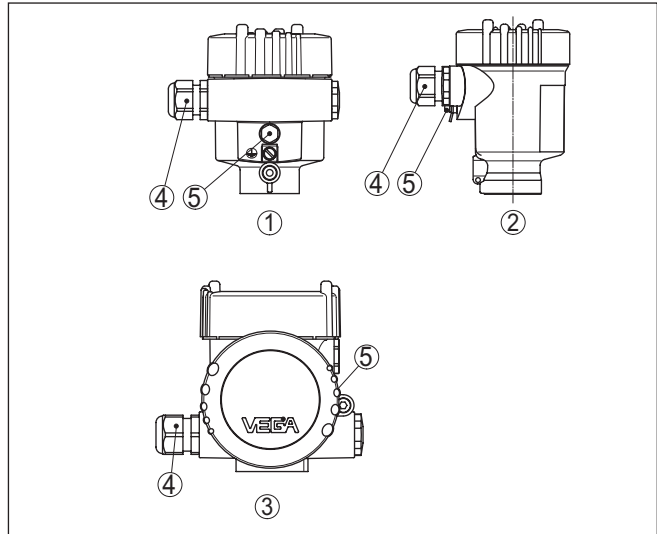

Fig. 2: Position of the cable gland and filter element with the different housing versions

- 1 Aluminium - single chamber
- 2 Stainless steel (precision casting), single chamber housing
- 3 Aluminium/Stainless steel double chamber
- 4 Cable gland
- 5 Filter element

Proceed as follows for mounting:

1. Unscrew the existing cable gland
2. Screw in the cable gland of the IP 66/IP 68, 1 bar connection cable
3. Connect the wires according to chapter "Connect"
4. Unscrew the filter element (consisting of four parts)
5. Screw in the blind plug
6. Lead the loose end of the connection cable into a suitable connection box with pressure compensation, e.g. VEGABOX 03

## 4 Connecting

### 4.1 Preparing the connection

**Safety instructions**

Always keep in mind the following safety instructions:



**Warning:**

Connect only in the complete absence of line voltage.

- The electrical connection must only be carried out by trained personnel authorised by the plant operator.

### 4.2 Wiring plan, supply cable (cable gland, single-sided)

**Pressure transmitter**

The following illustration applies to VEGABAR series 50 and 80 pressure transmitters.

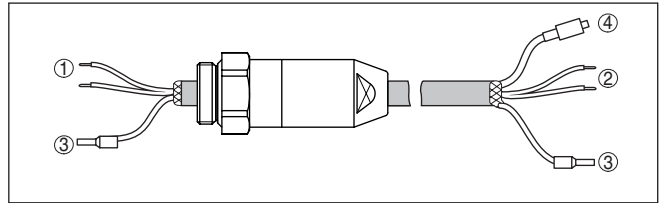

Fig. 3: Wire assignment connection cable

- 1 Brown (+) and blue (-) to the sensor
- 2 Brown (+) and blue (-) to power supply or to the processing system
- 3 Shielding
- 4 Breather capillaries

Wire colour	Terminal, electronics module	Function/Polarity
Brown	1	Voltage supply/+
Blue	2	Voltage supply/-
Black (screen)		Screen coating

**Continuous level sensors**

The following illustration applies to VEGAPULS, VEGASON, VEGACAL of series 60 as well as VEGAFLEX of series 60 and 80

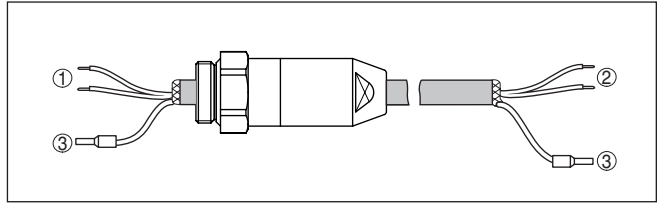



Fig. 5: Wire assignment connection cable

- 1 Brown (+) and blue (-) to the sensor
- 2 Brown (+) and blue (-) to power supply or to the processing system
- 3 Shielding

Wire colour	Terminal, electronics module	Function/Polarity
Brown	1	Voltage supply/+
Blue	2	Voltage supply/-
Black (screen)		Screen coating

**Level switch - Z-electronics**

The following illustration applies to VEGACAP, VEGAVIB, VEGASWING of series 60 - Z-electronics.

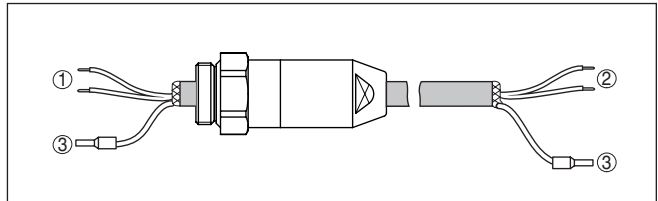



Fig. 7: Wire assignment connection cable

- 1 Brown (+) and blue (-) to the sensor
- 2 Brown (+) and blue (-) to power supply or to the processing system
- 3 Shielding

Wire colour	Terminal, electronics module	Function/Polarity
Brown	1	Voltage supply/+
Blue	2	Voltage supply/-
Black (screen)		Screen coating

**Limit switch - Transistor output**

The following illustration applies to VEGACAP, VEGAVIB, VEGASWING of series 60 - transistor output.



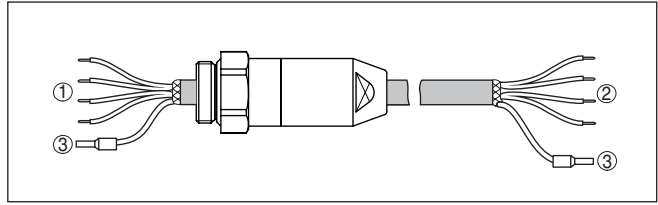



Fig. 9: Wire assignment connection cable

- 1 Brown, blue, white, yellow to the sensor
- 2 Brown, blue, white, yellow to voltage supply or to the processing system
- 3 Shielding

Wire colour	Terminal, electronics module	Function/Polarity
Brown	1	Voltage supply/+
Blue	4	Voltage supply/-
White	2	Transistor output/NPN-PNP
Yellow	3	Transistor output/NPN-PNP
Black (screen)		Screen coating

### 4.3 Wiring plan, display and adjustment cable (cable gland, double-sided)

#### Continuous sensors - external display and adjustment unit

The following illustration applies to continuous sensor in conjunction with external display and adjustment unit VEGADIS 61 or VEGADIS 81.

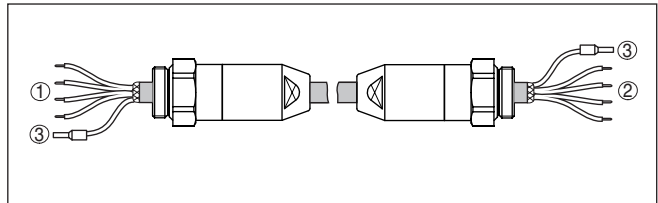



Fig. 11: Wire assignment connection cable

- 1 Brown, blue, white, yellow to the sensor
- 2 Brown, blue, white, yellow to VEGADIS 61 or VEGADIS 81
- 3 Shielding

Wire colour	Terminal, electronics module, sensor	Terminal, electronics module VEGADIS	Function
Brown	5	5	Voltage supply/ Communication
White	6	6	
Blue	7	7	
Yellow	8	8	
Black (screen)			Screen coating

## 5 Supplement

### 5.1 Technical data

#### Mechanical data

Configuration	Wires, strain relief, breather capillaries (with pressure transmitters), screen braiding, metal foil, mantle
Cable length	5 ... 180 m (16.40 ft ... 590.5 ft)
Min. bending radius at 25 °C/77 °F	25 mm (0.985 in)
Diameter approx.	8 mm (0.315 in)
Colour with material PE	Black
Colour with material PUR	Blue
Torque of the cable gland max.	5 Nm

#### Materials

Connection cable	PE, PUR
Cable gland	316L
Seal	FKM
Screw plug	316L

#### Temperature range

PE cable	-20 ... +60 °C (-4 ... +140 °F)
PUR cable	-20 ... +80 °C (-4 ... +176 °F)

#### Electrical data

Wire cross-section	0.5 mm <sup>2</sup> (AWG 20)
Wire resistance R'	0.037 Ω/m (0.012 Ω/ft)
Voltage range, max.	35 V DC

#### Protection rating

Sensor with connection cable	IP 66/IP 68 (1 bar)
------------------------------	---------------------

### 5.2 Dimensions

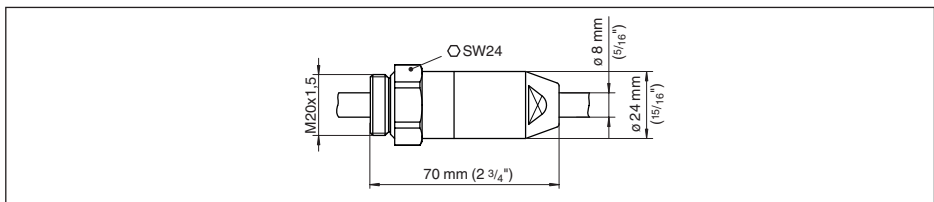

Fig. 14: Dimensions, cable gland connection cable IP 68/IP 68 (1 bar)

Printing date:

# VEGA

All statements concerning scope of delivery, application, practical use and operating conditions of the sensors and processing systems correspond to the information available at the time of printing.

Subject to change without prior notice

© VEGA Grieshaber KG, Schiltach/Germany 2018



34107-EN-180215

VEGA Grieshaber KG  
Am Hohenstein 113  
77761 Schiltach  
Germany

Phone +49 7836 50-0  
Fax +49 7836 50-201  
E-mail: [info.de@vega.com](mailto:info.de@vega.com)  
[www.vega.com](http://www.vega.com)