



Product information

Radiation-based

Density measurement

MINITRAC



Contents

1	Measuring principle	3
2	Type overview	4
3	Instrument selection	6
4	Housing overview	7
5	Mounting	8
6	Electronics - 4 ... 20 mA/HART	10
7	Electronics - Profibus PA	11
8	Electronics - Foundation Fieldbus	13
9	Adjustment	15
10	Dimensions - MINITRAC	17
11	Dimensions - Source holder VEGASOURCE 81, 82, 83	18

Take note of safety instructions for Ex applications



Please note the Ex specific safety information which you can find on our homepage www.vega.com/downloads under "Approvals" and which comes with every instrument. In hazardous areas you should take note of the corresponding regulations, conformity and type approval certificates of the sensors and power supply units. The sensors must only be operated on intrinsically safe circuits. The permissible electrical values are stated in the certificate.

1 Measuring principle

Measuring principle

Gamma rays can penetrate matter. During the transit, part of the radiation is absorbed depending on the density and thickness of the medium. For radiometric density measurement, this physical property can be used to measure contactlessly through a pipeline from the outside.

A detector detects the intensity of the gamma rays from a small radiation source. If medium is between detector and radiation source, a corresponding portion of the radiation is absorbed. The measurement is contactless from outside and hence suitable for extreme applications, for example, in very corrosive, aggressive and abrasive products.

Source holder

A Caesium or Cobalt source with low radiating intensity is enclosed in a source holder VEGASOURCE. The container consists of a lead-filled steel mantle that absorbs the gamma rays of the radioactive source, lowering them to permissible limit values. The focused radioactive rays can escape through a defined, closable radiation channel. Through a 180° rotation of the insert, the radiation channel is opened and the radiating source is swivelled into the radiation channel. The radioactive rays can thus escape.

The switch position (ON or OFF) is clearly visible from outside. The switch position "OFF" can be secured with a padlock.

A fire-proof version with an expansion tank is optionally available. In case of fire, the liquefied lead can spread into the expansion tank.

Sensor

The source holder VEGASOURCE with source and the detector MINITRAC are mounted on opposite sides of the pipeline. The strength of the received radiation is proportional to the density of the medium in the pipeline. The electronics of the detector calculates therefrom the density or concentration of the medium. When a temperature sensor is also connected, the electronics takes the heat expansion of the medium into account. The sensor then outputs the density of the medium at the reference temperature selected by the user, not the actual measured density.

Medium and pipeline

The pipeline or the medium itself does not become radioactive when penetrated by gamma rays. Matter cannot become radioactive in this way. The implemented pipeline will not get contaminated and can be disposed of normally when the system is disassembled.

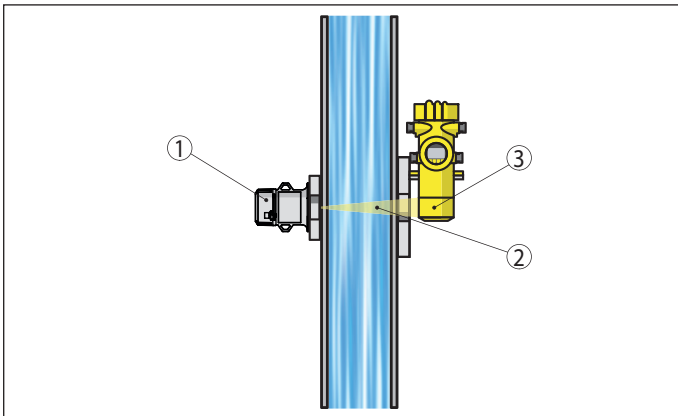

Fig. 1: Density measurement in a pipeline

- 1 Source holder (VEGASOURCE)
- 2 Radiated area
- 3 Detector (MINITRAC)

2 Type overview

MINITRAC 31



Application	Density measurement
Version	NaI detector integrated in the sensor housing
Mounting	Mounting from outside on the pipeline
Process temperature	any
Ambient temperature	-40 ... +60 °C
Process pressure	any
Measuring range	Depends on the application
Non-repeatability	±0.1 %
Voltage supply	20 ... 72 V DC, 20 ... 253 V AC, 50/60 Hz
Signal output	4 ... 20 mA/HART Profibus PA Foundation Fieldbus
Indication/Adjustment	PLICSCOM PACTware VEGADIS 81
Approvals	ATEX IEC FM CSA GOST

VEGASOURCE 81



VEGASOURCE 82



VEGASOURCE 83



Applications	Continuous level and interface measurement, density measurement	Continuous level and interface measurement, density measurement	Continuous level and interface measurement, density measurement
Number of the half-value layers typ.	Cs-137: 4.9	Cs-137: 8.6	Cs-137: 11.5
Max. activity of the source	Cs-137: 0.74 GBq (20 mCi)	Cs-137: 11.1 GBq (300 mCi)	Cs-137: 185 GBq (5000 mCi)
Exit angle	5° 30° 40° (± 20°) 45° 60° (± 30°)	5° 30° 40° (± 20°) 45° 60° (± 30°)	5° 30° 40° (± 20°) 45° 60° (± 30°)
Beam width	10°	10°	10°
Vessel material	316L or steel (1.0619) with PUR textured paint RAL 1018	316L or steel (1.0619) with PUR textured paint RAL 1018	316L or steel (1.0619) with PUR textured paint RAL 1018
Shielding material	Lead	Lead	Lead
Weight	approx. 11 kg (24.3 lbs) (with pneumatic changeover approx. 20 kg)	approx. 34 kg (75 lbs) (with pneumatic changeover approx. 46 kg)	approx. 82 kg (180 lbs) (with pneumatic changeover approx. 96 kg)
Process fitting	Mounting plate All process fittings are unpressurized and not in contact with the measured product	Mounting plate All process fittings are unpressurized and not in contact with the measured product	Mounting plate All process fittings are unpressurized and not in contact with the measured product
Process temperature	any	any	any
Process pressure	any	any	any
Ambient temperature	-50 ... +200 °C (-58 ... +392 °F)	-50 ... +200 °C (-58 ... +392 °F)	-50 ... +200 °C (-58 ... +392 °F)
Pneumatic remote operation	Pneumatic changeover acc. to ISO 7205, IEC 60405 (additional weight approx. 10 kg) Temperature range: -20 ... +80 °C (-4 ... +176 °F)	Version K, N - according to ISO 7205, IEC 60405 (additional weight approx. 10 kg) Temperature range: -20 ... +80 °C (-4 ... +176 °F)	acc. to ISO 7205, IEC 60405 (additional weight approx. 10 kg) Temperature range: -20 ... +80 °C (-4 ... +176 °F)
Flame resistance	+821 °C (+1510 °F) for 30 minutes	+821 °C (+1510 °F) for 30 minutes	+821 °C (+1510 °F) for 30 minutes
Transport packaging	Is deemed to be type A packaging according to the IATA directives	Is deemed to be type A packaging according to the IATA directives	Is deemed to be type A packaging according to the IATA directives

3 Instrument selection

Application area

Overview

The measuring system PROTRAC comprises the radiometric sensors FIBERTRAC, SOLITRAC and MINITRAC as well as the source holder VEGASOURCE with integrated radioactive source. The sensors consist of an active measuring component, the detector, as well as an electronics module. They have different designs and are suitable for many different application areas and uses.

A radiometric measuring system consists generally of the following components:

- Radioactive source
- Source holder
- Radiometric sensor

The selection of the radioactive source and the radioactive activity as well as the sensor depends on the dimensions of the vessel or the pipeline, the wall thicknesses, the density of the medium, installations in the path of the beam as well as the measuring range.

Radiometric sensor

The radiometric sensor MINITRAC has a point-shaped detector with an inorganic scintillator of sodium iodide (NaI) for non-contact level detection and density measurement. This scintillator is characterized by a high sensitivity. The sensor is used on vessels with any geometry and on pipelines.

Source holder

The source holder VEGASOURCE serves as a receptacle for the radioactive source. It is available in two sizes. Source Co-60 or Cs-137 with selectable radiating activity is used as radiation source. The radiation activity depends on the application.

Density measurement in pipelines

MINITRAC is used for density measurement in pipelines. The pulse rates of the medium with known density is stored in the MINITRAC as calibration data for the density measurement. As an alternative, the pulse rate of the actual medium can also be detected and the density determined in the laboratory. From this the electronics generates a table with pulse rate/density value pairs (linearisation curve). These data are used to calculate the corresponding density from the actual pulse rate.

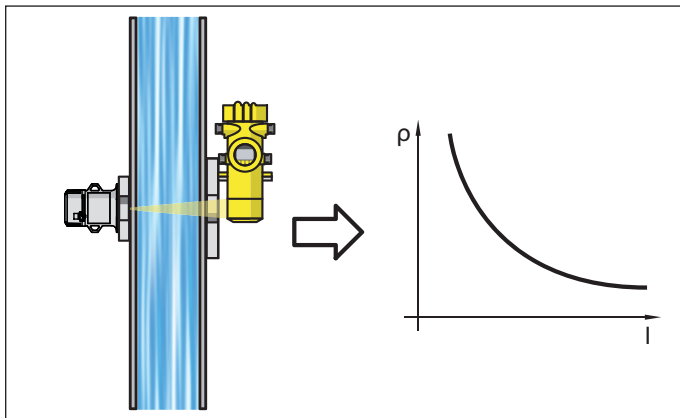

Fig. 2: Density measurement

I Pulse rate
 ρ Density

The concentration of the medium can be determined from the measured density. For this purpose, an additional table with value pairs density/concentration (linearization curve) must be entered. The concentration of acids and alcais as well as the solid content in liquids can thus be measured.

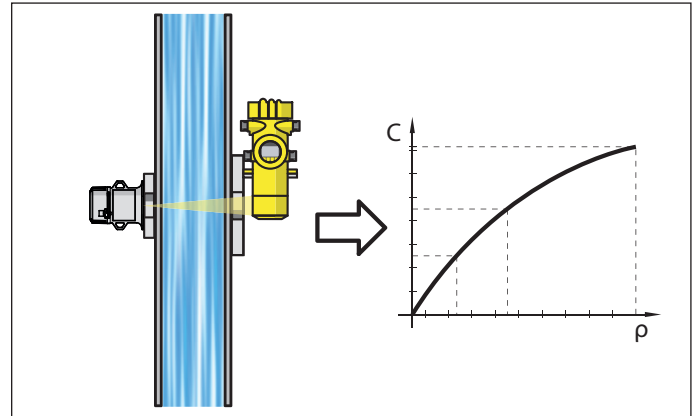

Fig. 3: Concentration measurement

ρ Density
 C Concentration

4 Housing overview

Housing configuration

The housing is divided into the following chambers:

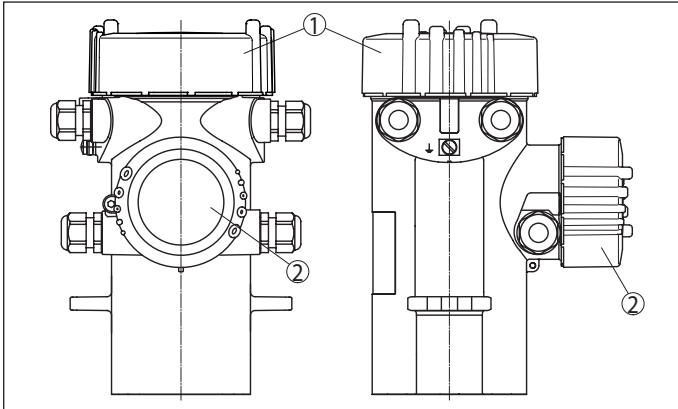



Fig. 4: Instrument housing

- 1 Electronics and connection compartment (top)
- 2 Adjustment and connection compartment (lateral)

Aluminium	
Protection rating	IP66/IP67, IP66/IP68 (1 bar)
Version	Double chamber
Application area	Industrial environment with increased mechanical stress

Stainless steel 316L	
Protection rating	IP66/IP67, IP66/IP68 (1 bar)
Version	Double chamber, precision casting
Application area	Aggressive environment, extreme mechanical stress

5 Mounting

Installation position

The ideal measurement arrangement for the density measurement, is the mounting on a vertical pipeline. The pipe diameter can be 50 ... 600 mm. The flow direction should be from bottom to top.

Mounting brackets, angled attachments as well as mounting clamps are available for mounting.

Vertical pipeline, diameter 50 ... 100 mm

With pipeline diameters of 50 ... 100 mm, a diagonal radiation path is recommended. The distance of the beam through the medium is thus longer and an improved measuring effect is achieved. For this the optional lead shielding for the detector is recommended in order to avoid influence from secondary radiation sources.



Fig. 5: Measurement arrangement on a pipeline with a diameter of 50 ... 100 mm

Vertical pipeline, diameter 100 ... 420 mm

With pipeline diameters of 100 ... 420 mm, a straight radiation path is possible. The radiometric sensor can be mounted either horizontally or vertically.

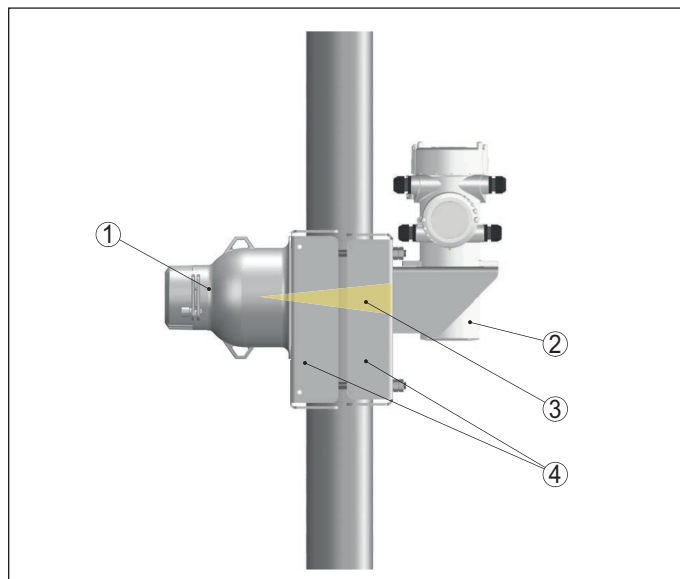

Fig. 6: Measurement arrangement on a pipeline with a diameter of 100 ... 420 mm, detector mounting vertically

- 1 Source holder (VEGASOURCE)
- 2 Radiometric sensor (MINITRAC)
- 3 Radiated area
- 4 Mounting bracket

When mounting the radiometric sensor horizontally, the optional lead shielding is recommended in order to avoid influence from secondary radiation sources.

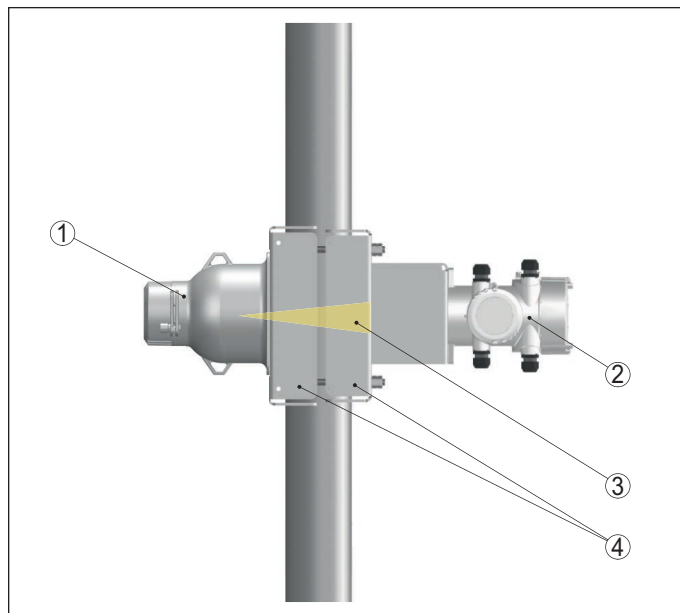

Fig. 7: Measurement setup on a pipeline with a diameter of 100 ... 420 mm, detector mounted horizontally

- 1 Source holder (VEGASOURCE)
- 2 Radiometric sensor (MINITRAC)
- 3 Radiated area
- 4 Mounting bracket

Horizontal pipeline

On a horizontal pipeline, the radiation should be directed horizontally to avoid interference from air pockets.

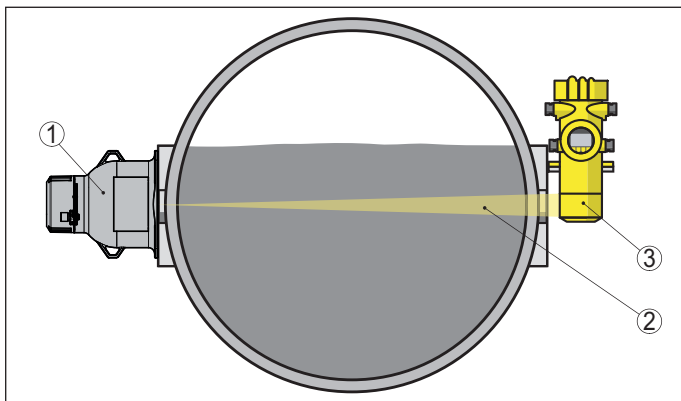

Fig. 8: Measurement setup on a horizontal pipeline

- 1 Source holder (VEGASOURCE)
- 2 Radiated area
- 3 Detector (MINITRAC)

Mounting instructions - VEGASOURCE

The exit angle of the source holder VEGASOURCE must be directed to the measuring range of the sensor mounted on the opposite side.

The source holder VEGASOURCE should be mounted close to the vessel. If there are gaps, protect the area by a safety fence and a grid against grasping into the dangerous area. Such areas should be marked respectively.

6 Electronics - 4 ... 20 mA/HART

Configuration of the electronics

The pluggable electronics is mounted in the electronics and connection compartment of the instrument and can be exchanged by the user when servicing is required. The electronics is completely encapsulated to protect against vibration and moisture.

The terminals for voltage supply, measuring signal output as well as further analogue, digital and serial interfaces are located on the upper side of the electronics.

This output is located in the adjustment and connection compartment on instrument versions with intrinsically safe (IS) measuring signal output.

Voltage supply/Signal processing

If a reliable separation is required, the supply voltage and the measurement signal are transmitted over separate two-wire connection cables.

- Operating voltage
 - 20 ... 72 V DC, 20 ... 253 V AC, 50/60 Hz

Connection cable

The 4 ... 20 mA current output is connected with standard two-wire cable without shielding. If electromagnetic interference is expected which is above the test values of EN 61326 for industrial areas, shielded cable should be used.

For voltage supply, an approved installation cable with PE conductor is required.

Cable screening and grounding

If shielded cable is required, we recommend connecting the cable screening on both ends to ground potential. In the sensor, the cable screening should be connected directly to the internal ground terminal. The ground terminal on the outside of the housing must be connected to the ground potential (low impedance).

Connection non-Ex instruments

Electronics and connection compartment

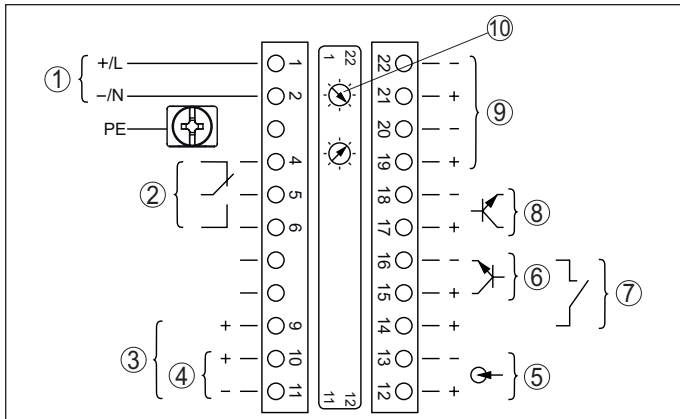

Fig. 9: Electronics and connection compartment with non-Ex instruments and instruments with non-intrinsically safe current output

- 1 Voltage supply
- 2 Relay output
- 3 Signal output 4 ... 20 mA/HART, active
- 4 Signal output 4 ... 20 mA/HART, passive
- 5 Signal input 4 ... 20 mA
- 6 Switching input for NPN transistor
- 7 Switching input floating
- 8 Transistor output
- 9 Interface for sensor-sensor communication
- 10 Bus address setting for sensor-sensor communication

Adjustment and connection compartment

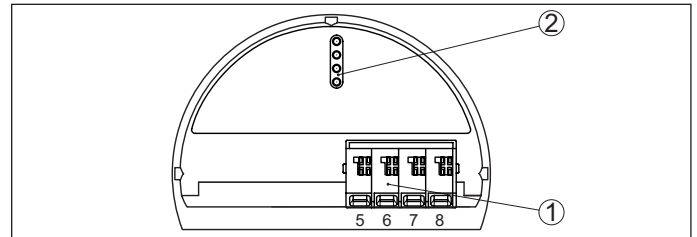

Fig. 10: Adjustment and connection compartment with non-Ex instruments and instruments with non-intrinsically safe current output

- 1 Terminals for the external display and adjustment unit
- 2 Contact pins for the display and adjustment module or interface adapter

Connection Ex instruments

Electronics and connection compartment

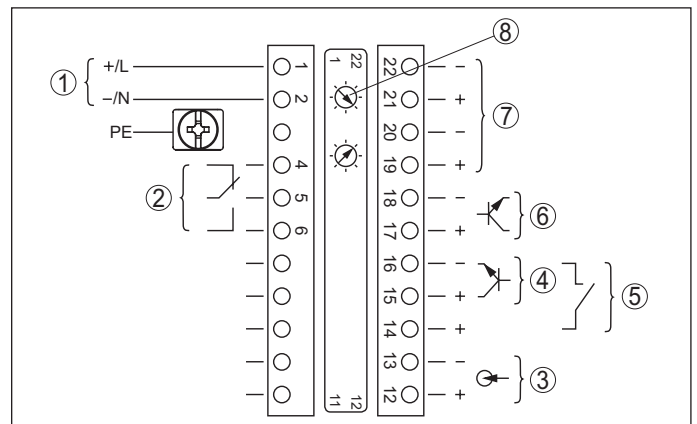

Fig. 11: Electronics and connection compartment with Ex instruments

- 1 Voltage supply
- 2 Relay output
- 3 Signal input 4 ... 20 mA
- 4 Switching input for NPN transistor
- 5 Switching input floating
- 6 Transistor output
- 7 Interface for sensor-sensor communication
- 8 Bus address setting for sensor-sensor communication

Adjustment and connection compartment

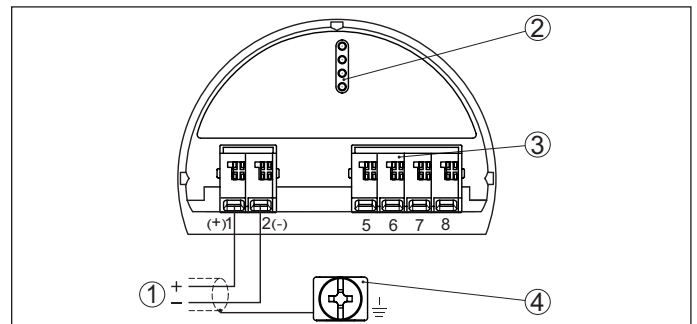

Fig. 12: Adjustment and connection compartment with Ex instruments with intrinsically safe current output

- 1 Terminals for intrinsically safe signal output 4 ... 20 mA/HART, active
- 2 Contact pins for the display and adjustment module or interface adapter
- 3 Terminals for external display and adjustment unit
- 4 Ground terminal for connection of the cable screening

7 Electronics - Profibus PA

Configuration of the electronics

The pluggable electronics is mounted in the electronics and connection compartment of the instrument and can be exchanged by the user when servicing is required. The electronics is completely encapsulated to protect against vibration and moisture.

The terminals for voltage supply, measuring signal output as well as further analogue, digital and serial interfaces are located on the upper side of the electronics.

This output is located in the adjustment and connection compartment on instrument versions with intrinsically safe (IS) measuring signal output.

Voltage supply/Signal processing

If a reliable separation is required, the supply voltage and the measurement signal are transmitted over separate two-wire connection cables.

- Operating voltage
 - 20 ... 72 V DC, 20 ... 253 V AC, 50/60 Hz

Connection cable

Connection is carried out with shielded cable according to Profibus specification.

Make sure that the entire installation is carried out according to the Profibus specification. In particular, make sure that the bus is terminated with suitable terminating resistors.

Cable screening and grounding

In systems with potential equalisation, connect the cable screening directly to ground potential at the power supply unit, in the connection box and at the sensor. The screen in the sensor must be connected directly to the internal ground terminal. The ground terminal outside on the housing must be connected to the potential equalisation (low impedance).

In systems without potential equalisation, connect the cable shielding directly to ground potential on the power supply unit and the sensor. In the connection box or T-distributor, the shielding of the short stub to the sensor may not be connected to ground potential or to another cable screening.

Connection non-Ex instrument

Electronics and connection compartment

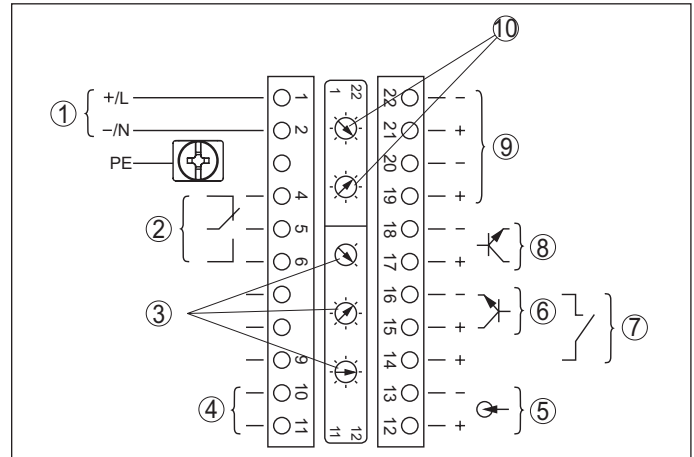

Fig. 13: Electronics and connection compartment with non-Ex instruments and instruments with non-intrinsically safe signal output

- 1 Voltage supply
- 2 Relay output
- 3 Adjustment bus address for Profibus PA
- 4 Signal output Profibus PA
- 5 Signal input 4 ... 20 mA (active sensor)
- 6 Switching input for NPN transistor
- 7 Switching input floating
- 8 Transistor output
- 9 Interface for sensor-sensor communication
- 10 Bus address setting for sensor-sensor communication

Adjustment and connection compartment

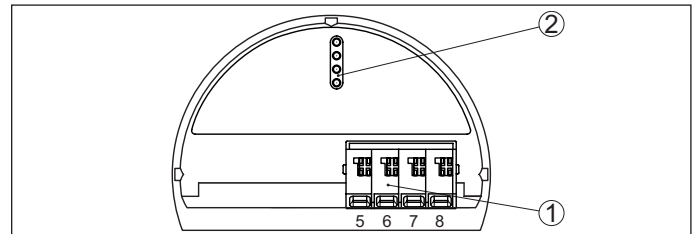

Fig. 14: Adjustment and connection compartment with non-Ex instruments and instruments with non-intrinsically safe signal output

- 1 Terminals for the external display and adjustment unit
- 2 Contact pins for the display and adjustment module or interface adapter

Connection Ex instrument

Electronics and connection compartment

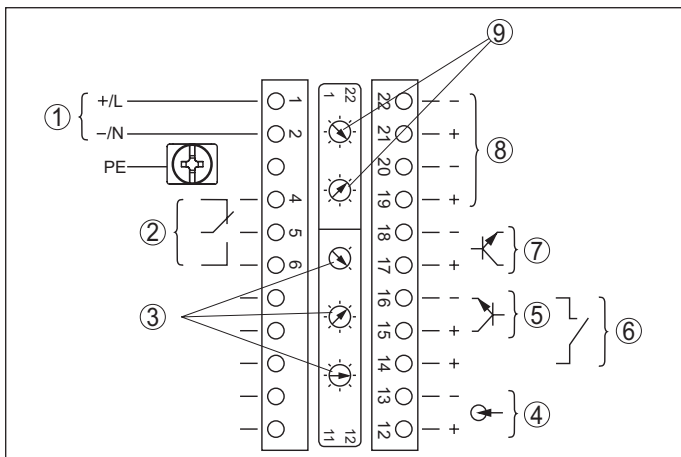

Fig. 15: Electronics and connection compartment (Ex d) with instruments with intrinsically safe signal output

- 1 Voltage supply
- 2 Relay output
- 3 Adjustment bus address for Profibus PA
- 4 Signal input 4 ... 20 mA (active sensor)
- 5 Switching input for NPN transistor
- 6 Switching input floating
- 7 Transistor output
- 8 Interface for sensor-sensor communication
- 9 Bus address setting for sensor-sensor communication

Adjustment and connection compartment

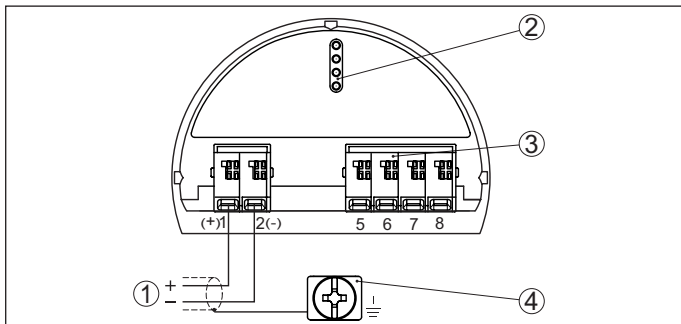

Fig. 16: Adjustment and connection compartment (Ex ia) with instruments with intrinsically safe signal output

- 1 Terminals - Signal output Profibus PA
- 2 Contact pins for the display and adjustment module or interface adapter
- 3 Terminals for the external display and adjustment unit
- 4 Ground terminal

8 Electronics - Foundation Fieldbus

Configuration of the electronics

The pluggable electronics is mounted in the electronics and connection compartment of the instrument and can be exchanged by the user when servicing is required. The electronics is completely encapsulated to protect against vibration and moisture.

The terminals for voltage supply, measuring signal output as well as further analogue, digital and serial interfaces are located on the upper side of the electronics.

This output is located in the adjustment and connection compartment on instrument versions with intrinsically safe (IS) measuring signal output.

Voltage supply/Signal processing

If a reliable separation is required, the supply voltage and the measurement signal are transmitted over separate two-wire connection cables.

- Operating voltage
 - 20 ... 72 V DC, 20 ... 253 V AC, 50/60 Hz

Connection cable

Connection is carried out with shielded cable according to Fieldbus specification.

Make sure that the entire installation is carried out according to the Fieldbus specification. In particular, make sure that the bus is terminated with suitable terminating resistors.

Cable screening and grounding

In systems with potential equalisation, connect the cable screening directly to ground potential at the power supply unit, in the connection box and at the sensor. The screen in the sensor must be connected directly to the internal ground terminal. The ground terminal outside on the housing must be connected to the potential equalisation (low impedance).

In systems without potential equalisation, connect the cable shielding directly to ground potential on the power supply unit and the sensor. In the connection box or T-distributor, the shielding of the short stub to the sensor may not be connected to ground potential or to another cable screening.

Connection non-Ex instrument

Electronics and connection compartment

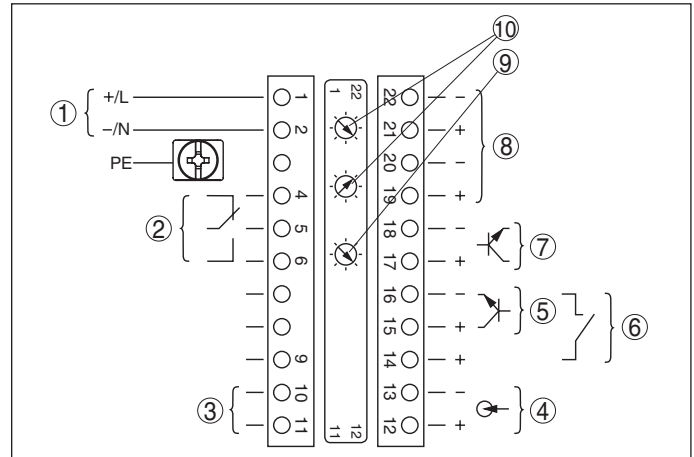

Fig. 17: Electronics and connection compartment with non-Ex instruments and instruments with non-intrinsically safe signal output

- 1 Voltage supply
- 2 Relay output
- 3 Signal output FF bus
- 4 Signal input 4 ... 20 mA (active sensor)
- 5 Switching input for NPN transistor
- 6 Switching input floating
- 7 Transistor output
- 8 Interface for sensor-sensor communication
- 9 Simulation switch (1 = simulation on)
- 10 Bus address setting for sensor-sensor communication

Adjustment and connection compartment

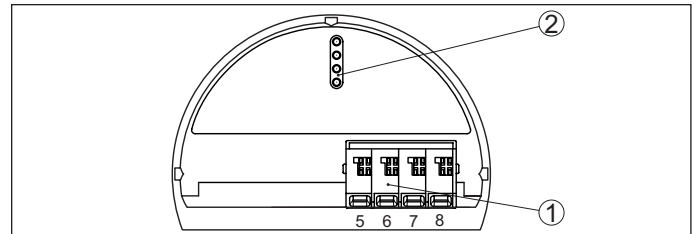

Fig. 18: Adjustment and connection compartment with non-Ex instruments and instruments with non-intrinsically safe signal output

- 1 Terminals for the external display and adjustment unit
- 2 Contact pins for the display and adjustment module or interface adapter

Connection Ex instrument

Electronics and connection compartment

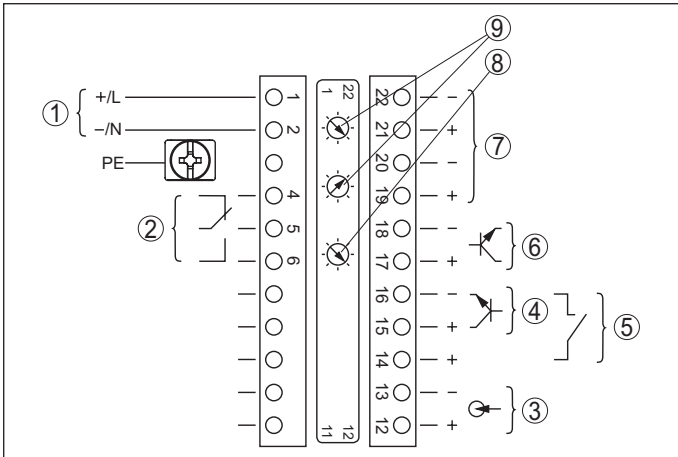

Fig. 19: Electronics and connection compartment (Ex d) with instruments with intrinsically safe signal output

- 1 Voltage supply
- 2 Relay output
- 3 Signal input 4 ... 20 mA (active sensor)
- 4 Switching input for NPN transistor
- 5 Switching input floating
- 6 Transistor output
- 7 Interface for sensor-sensor communication
- 8 Simulation switch (1 = simulation on)
- 9 Bus address setting for sensor-sensor communication

Adjustment and connection compartment

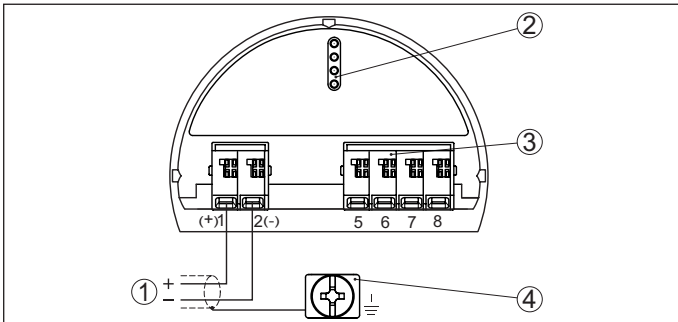

Fig. 20: Adjustment and connection compartment (Ex ia) with instruments with intrinsically safe signal output

- 1 Terminals for intrinsically safe signal output FF bus
- 2 Contact pins for the display and adjustment module or interface adapter
- 3 Terminals for the external display and adjustment unit
- 4 Ground terminal

9 Adjustment

9.1 Adjustment directly at the measuring point

Via the display and adjustment module through keys

The plug-in display and adjustment module is used for measured value indication, adjustment and diagnosis. It is equipped with an illuminated full dot matrix as well as four keys for adjustment.



Fig. 21: Display and adjustment module - Kay adjustment

Via the display and adjustment module through magnetic pen

With the Bluetooth version of the display and adjustment module, the sensor can also be adjusted with the magnetic pen. This is done right through the closed lid (with inspection window) of the sensor housing.

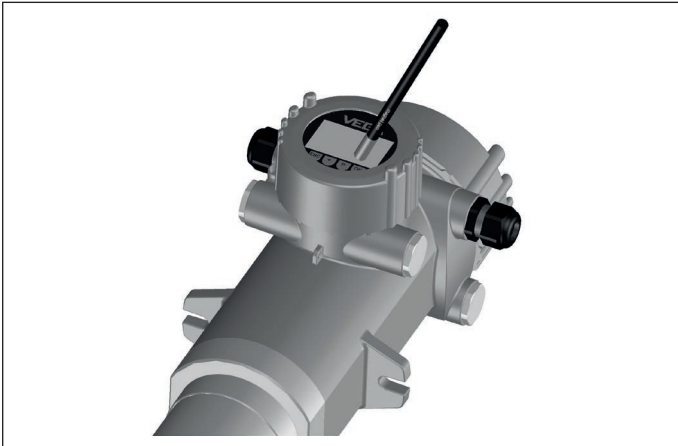

Fig. 22: Display and adjustment module - Adjustment via magnetic pen

Via a PC with PACTware/DTM

The interface adapter VEGACONNECT is required for connection of the PC. The converter is placed on the sensor instead of the display and adjustment module and connected to the USB interface of the PC.

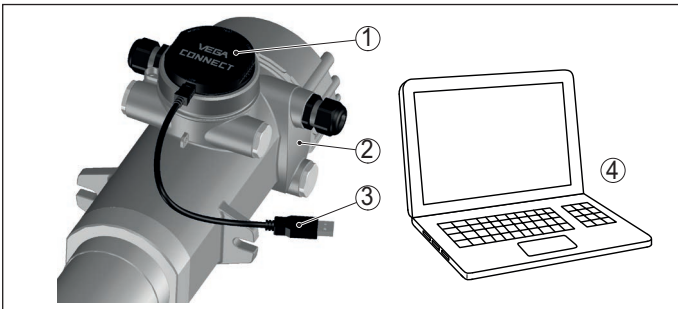

Fig. 23: Connection of the PC via VEGACONNECT and USB

- 1 Interface adapter VEGACONNECT
- 2 Sensor
- 3 USB cable to the PC
- 4 PC with PACTware/DTM

PACTware is an adjustment software for configuration, parameter adjustment, documentation and diagnosis of field devices. The corresponding device drivers are called DTMs.

9.2 Operation in the measurement loop environment - wireless via Bluetooth

Via a smartphone/tablet

The display and adjustment module with integrated Bluetooth functionality allows wireless connection to smartphones/tablets with iOS or Android operating system. The adjustment is carried out via the VEGA Tools app from the Apple App Store or Google Play Store.

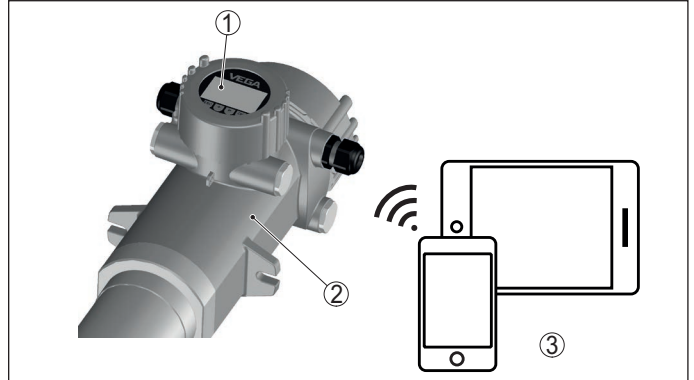

Fig. 24: Wireless connection to smartphones/tablets

- 1 Display and adjustment module
- 2 Sensor
- 3 Smartphone/Tablet

Via a PC with PACTware/DTM

The wireless connection from the PC to the sensor is carried out via the Bluetooth USB adapter and a display and adjustment module with integrated Bluetooth function. The adjustment is carried out via the PC with PACTware/DTM.

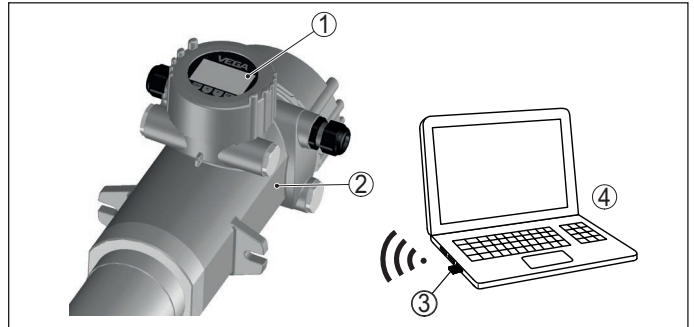

Fig. 25: Wireless connection of the PC via Bluetooth USB adapter

- 1 Display and adjustment module
- 2 Sensor
- 3 Bluetooth USB adapter
- 4 PC with PACTware/DTM

9.3 Adjustment carried out at position remote from the measuring point - wired

Via external display and adjustment units

The external display and adjustment unit VEGADIS 81 is available for this purpose. The adjustment is carried out via the keys of the display and adjustment module built-in or alternatively with the magnetic pen.

VEGADIS 81 is mounted up to 50 m away from the sensor and connected directly to the electronics of the sensor.

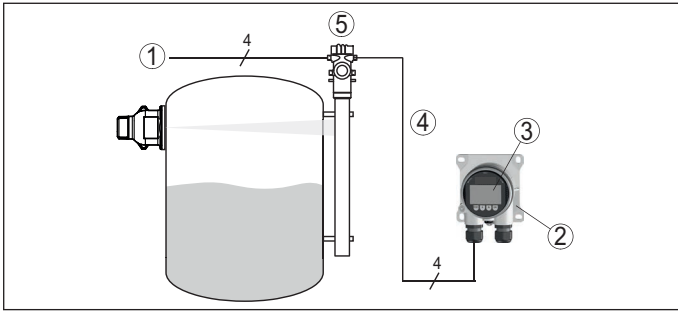

Fig. 26: Connection of VEGADIS 81 to the sensor

- 1 Voltage supply/Signal output sensor
- 2 External display and adjustment unit
- 3 Display and adjustment module
- 4 Connection cable sensor - external display and adjustment unit
- 5 Sensor

Via a PC with PACTware/DTM - Bluetooth

The sensor adjustment is carried out with a PC with PACTware/DTM via a Bluetooth connection.

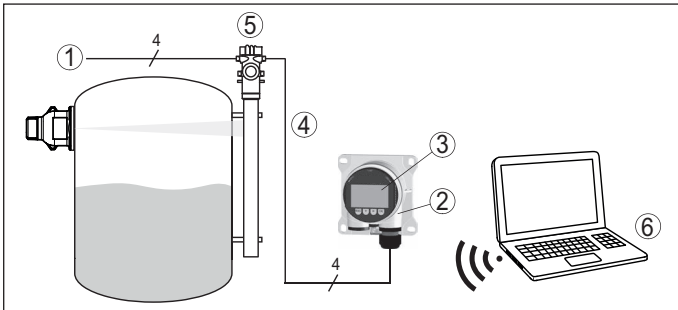

Fig. 27: Connection of VEGADIS 81 to the sensor, adjustment via PC with PACTware with Bluetooth

- 1 Voltage supply/Signal output sensor
- 2 External display and adjustment unit
- 3 Display and adjustment module
- 4 Connection cable sensor - external display and adjustment unit
- 5 Sensor
- 6 PC with PACTware/DTM

Via a PC mit PACTware/DTM - radiation through wire

The sensor adjustment is carried out with a PC with PACTware/DTM via a USB connection cable. For connection of the PC, the VEGACONNECT interface adapter is required.

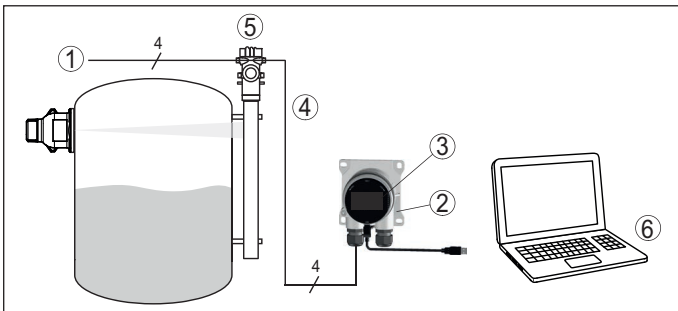

Fig. 28: Connection of VEGADIS 81 to the sensor, adjustment via PC with PACTware, radiation through wire

- 1 Voltage supply/Signal output sensor
- 2 External display and adjustment unit
- 3 Interface adapter VEGACONNECT
- 4 Connection cable sensor - external display and adjustment unit
- 5 Sensor
- 6 PC with PACTware/DTM

9.4 Alternative adjustment programs

DD adjustment programs

Device descriptions as Enhanced Device Description (EDD) are available for DD adjustment programs such as, for example, AMS™ and PDM.

The files can be downloaded at www.vega.com/downloads under "Software".

Field Communicator 375, 475

Device descriptions for the instruments are available as EDD for parameterisation with Field Communicator 375 or 475.

Integrating the EDD into the Field Communicator 375 or 475 requires the "Easy Upgrade Utility" software, which is available from the manufacturer. This software is updated via the Internet and new EDDs are automatically accepted into the device catalogue of this software after they are released by the manufacturer. They can then be transferred to a Field Communicator.

10 Dimensions - MINITRAC

The listed drawings are only an excerpt of the available process fittings. You can find more drawings on our homepage "www.vega.com/Downloads/Drawings".

Aluminium and stainless steel housing

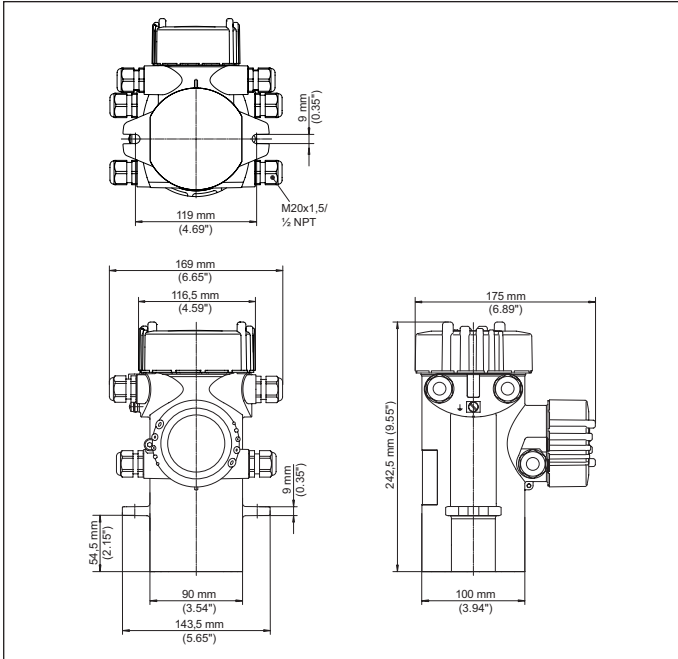
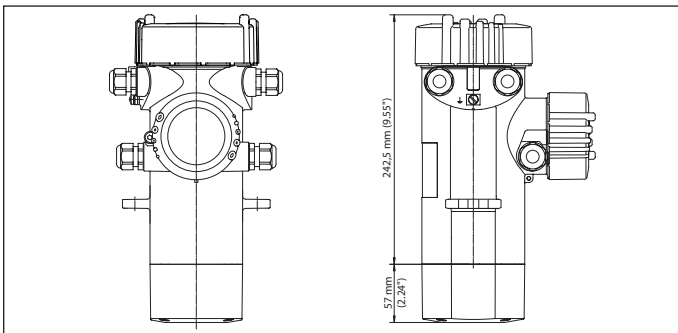

Fig. 29: Aluminium housing or stainless steel housing (precision casting)

MINITRAC 31



11 Dimensions - Source holder VEGASOURCE 81, 82, 83

Source holder VEGASOURCE 81, version X, C - Manual changeover

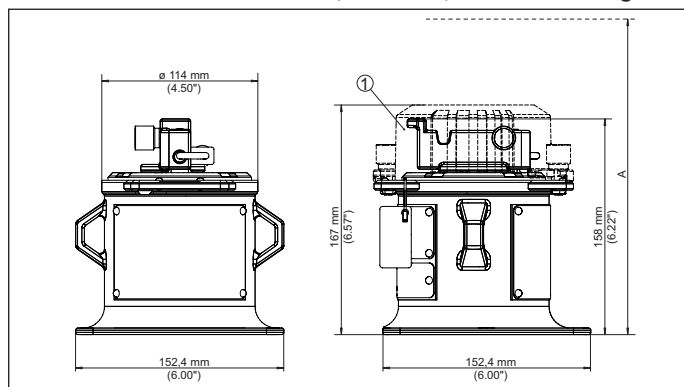

Fig. 30: Source holder VEGASOURCE 81, version X, C - Manual changeover

1 Cover (optional)

A Free height for removal of the loading tube = 310 mm (12.21 in)

Source holder VEGASOURCE 82, version X, C - Manual changeover

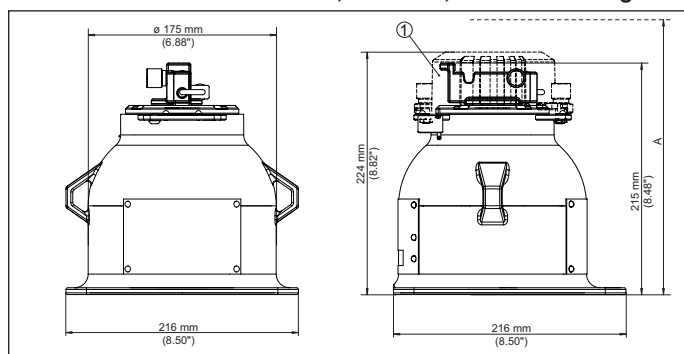

Fig. 31: Source holder VEGASOURCE 82, version X, C - Manual changeover

1 Cover (optional)

A Free height for removal of the loading tube = 310 mm (12.21 in)

Source holder VEGASOURCE 83, version X, C - Manual changeover

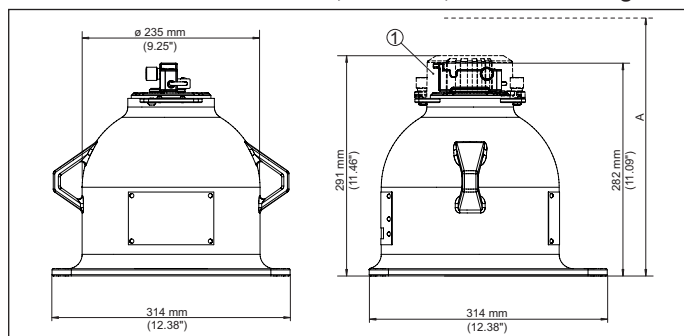

Fig. 32: Source holder VEGASOURCE 83, version X, C - Manual changeover

1 Cover (optional)

A Free height for removal of the loading tube = 310 mm (12.21 in)

Optional versions - VEGASOURCE 81, 82, 83

The following optional accessories can be fitted to all series 80 source holders.

The optional accessories on a VEGASOURCE 82 are shown as an example.

Source holder VEGASOURCE 82, version X, C - Manual changeover with ON/OFF position switches

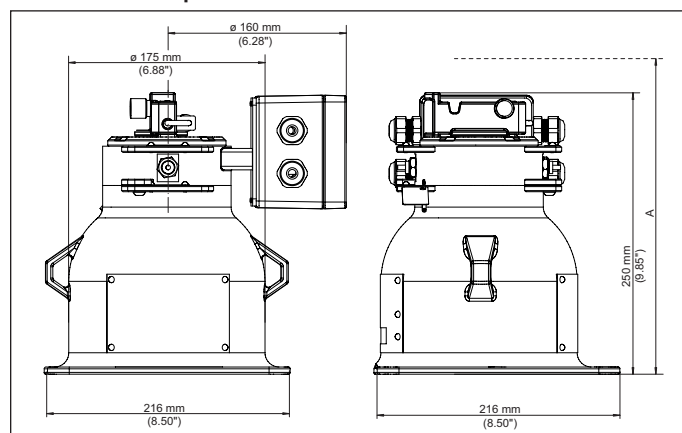

Fig. 33: Source holder VEGASOURCE 82, version X, C - Manual changeover with ON/OFF position switches

A Free height for removal of the loading tube = 335 mm (13.19 in)

Source holder VEGASOURCE 82, version X, C - Manual changeover with Interlock switch

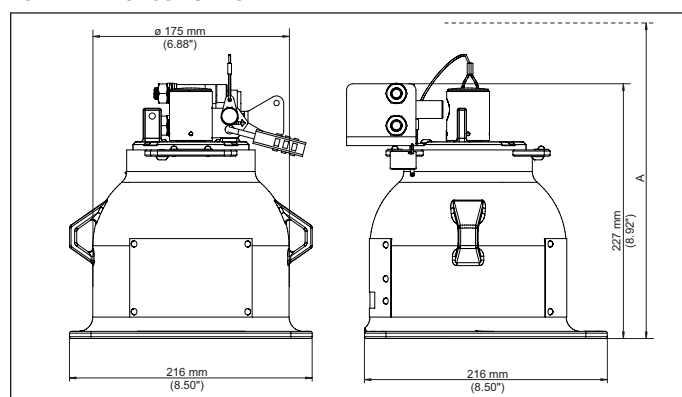

Fig. 34: Source holder VEGASOURCE 82, version X, C - Manual changeover with Interlock switch

A Free height for removal of the loading tube = 335 mm (13.19 in)

Source holder VEGASOURCE 82, version B - Pneumatic changeover

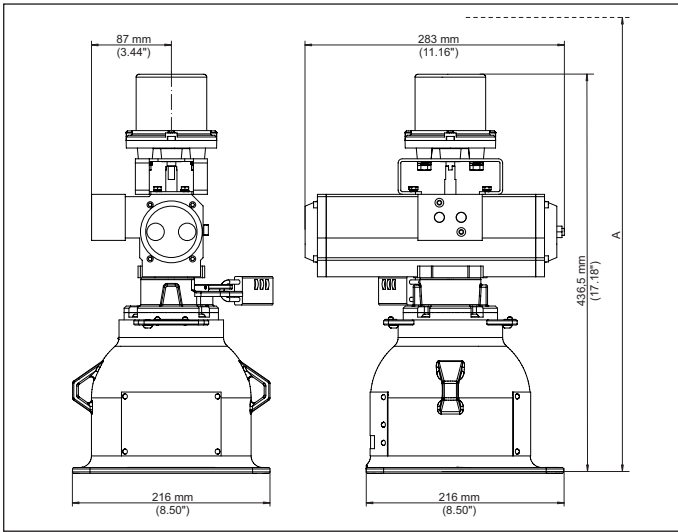

Fig. 35: Source holder VEGASOURCE 82, version B - Pneumatic changeover
 A Free height for removal of the loading tube = 558 mm (21.97 in)

Source holder VEGASOURCE 82, version B - Pneumatic changeover with ON/OFF position switches

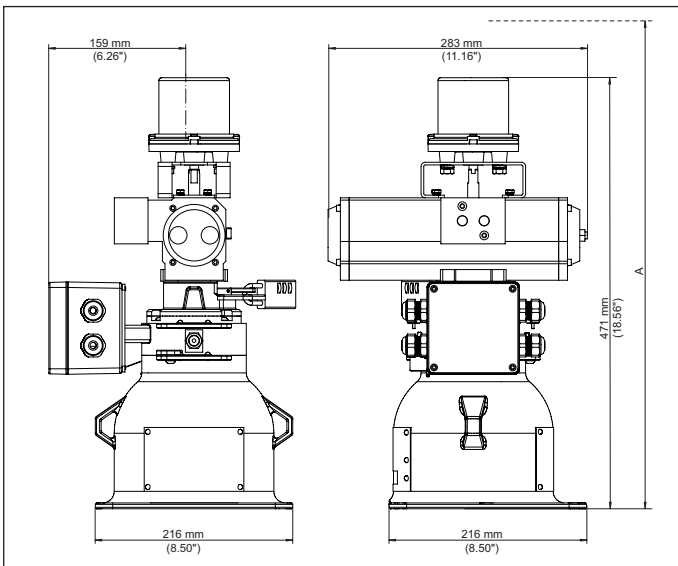

Fig. 36: Source holder VEGASOURCE 82, version B - Pneumatic changeover with ON/OFF position switches
 A Free height for removal of the loading tube = 558 mm (21.97 in)

Gamma modulator (optional)

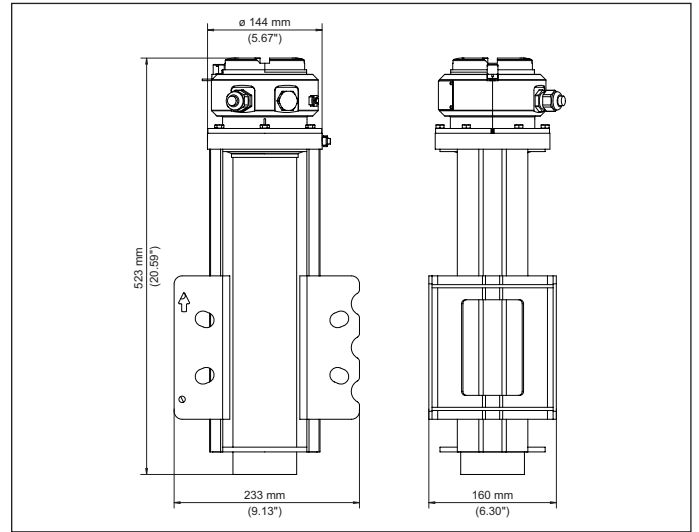

Fig. 37: Gamma modulator for uninterrupted measurement even with X-ray radiation

Mounting brackets KV 31, for pipes from 50 ... 100 mm (1.97 ... 3.94 in) for 30° diagonal irradiation



Fig. 38: Mounting brackets for diagonal mounting on pipes from 50 ... 100 mm (1.97 ... 3.94 in)

**Mounting brackets KV 31, for pipes from 50 ... 220 mm
(1.97 ... 8.66 in)**

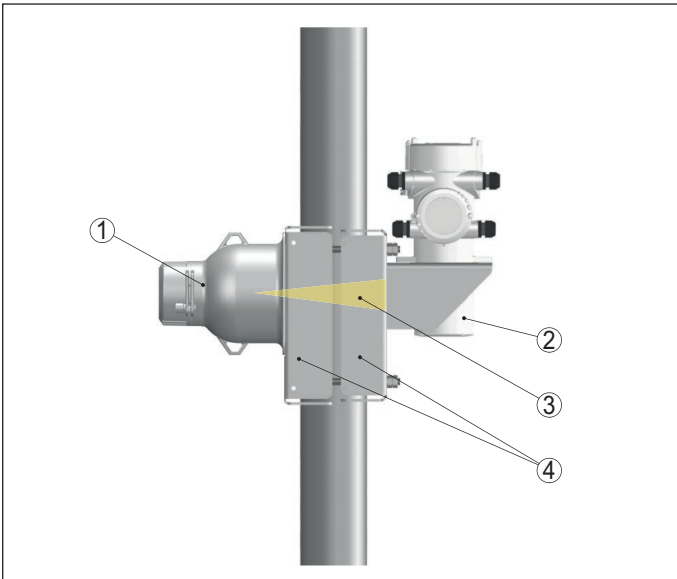

*Fig. 39: Mounting brackets for mounting on pipes from 50 ... 220 mm
(1.97 ... 8.66 in) for 30° diagonal irradiation*

- 1 Source holder (VEGASOURCE)
- 2 Radiometric sensor (MINITRAC)
- 3 Radiated area
- 4 Mounting bracket

**Mounting brackets KV 31, for pipes from 50 ... 220 mm
(1.97 ... 8.66 in)**

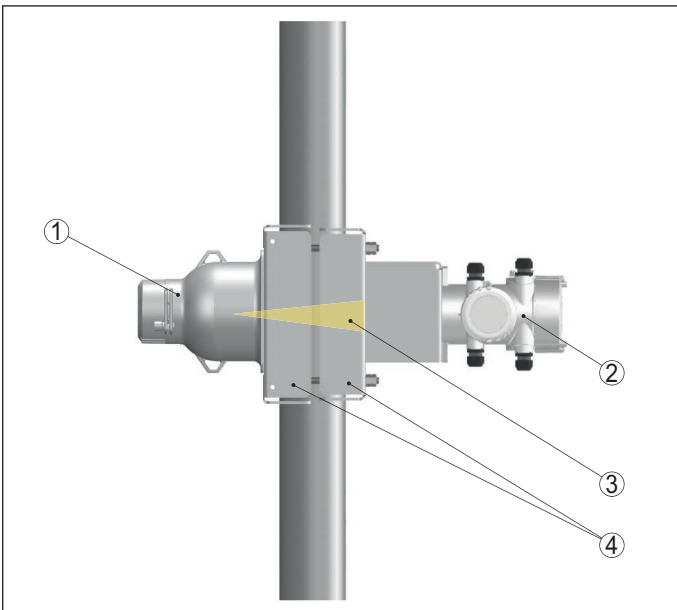

*Fig. 40: Mounting brackets for mounting on pipes from 50 ... 220 mm
(1.97 ... 8.66 in)*

- 1 Source holder (VEGASOURCE)
- 2 Radiometric sensor (MINITRAC)
- 3 Radiated area
- 4 Mounting bracket



All statements concerning scope of delivery, application, practical use and operating conditions of the sensors and processing systems correspond to the information available at the time of printing.
Subject to change without prior notice

© VEGA Grieshaber KG, Schiltach/Germany 2026

VEGA Grieshaber KG
Am Hohenstein 113
77761 Schiltach
Germany

Phone +49 7836 50-0
E-mail: info.de@vega.com
www.vega.com

VEGA

37281-EN-260507