

# Operating Instructions

## Overvoltage protection

### B 61-300

For supply and control cables



Document ID: 40488



**VEGA**

# Contents

<b>1</b>	<b>About this document</b> .....	<b>3</b>
1.1	Function .....	3
1.2	Target group .....	3
1.3	Symbols used.....	3
<b>2</b>	<b>For your safety</b> .....	<b>4</b>
2.1	Authorised personnel .....	4
2.2	Appropriate use.....	4
2.3	Warning about incorrect use.....	4
2.4	General safety instructions .....	4
2.5	Installation and operation in the USA and Canada .....	5
<b>3</b>	<b>Product description</b> .....	<b>6</b>
3.1	Configuration.....	6
3.2	Principle of operation.....	6
3.3	Packaging, transport and storage.....	7
<b>4</b>	<b>Mounting instructions</b> .....	<b>8</b>
4.1	Installation in switching cabinet .....	8
4.2	Mounting in housing .....	9
<b>5</b>	<b>Connecting to power supply</b> .....	<b>11</b>
5.1	Preparing the connection .....	11
5.2	Connection steps for version with housing .....	11
5.3	Wiring plan .....	12
<b>6</b>	<b>Diagnostics and servicing</b> .....	<b>13</b>
6.1	Maintenance .....	13
6.2	Rectify faults.....	13
6.3	How to proceed if a repair is necessary.....	13
<b>7</b>	<b>Dismount</b> .....	<b>14</b>
7.1	Dismounting steps.....	14
7.2	Disposal .....	14
<b>8</b>	<b>Certificates and approvals</b> .....	<b>15</b>
8.1	Conformity.....	15
8.2	Environment management system .....	15
<b>9</b>	<b>Supplement</b> .....	<b>16</b>
9.1	Technical data .....	16
9.2	Dimensions B61-300.....	17
9.3	Industrial property rights.....	19
9.4	Trademark .....	19

# 1 About this document

## 1.1 Function

This instruction provides all the information you need for mounting, connection and setup as well as important instructions for maintenance, fault rectification, safety and the exchange of parts. Please read this information before putting the instrument into operation and keep this manual accessible in the immediate vicinity of the device.

## 1.2 Target group

This instruction manual is directed to trained personnel. The contents of this manual must be made available to the qualified personnel and implemented.

## 1.3 Symbols used



### Document ID

This symbol on the front page of this instruction refers to the Document ID. By entering the Document ID on [www.vega.com](http://www.vega.com) you will reach the document download.



**Information, note, tip:** This symbol indicates helpful additional information and tips for successful work.



**Note:** This symbol indicates notes to prevent failures, malfunctions, damage to devices or plants.



**Caution:** Non-observance of the information marked with this symbol may result in personal injury.



**Warning:** Non-observance of the information marked with this symbol may result in serious or fatal personal injury.



**Danger:** Non-observance of the information marked with this symbol results in serious or fatal personal injury.



### Ex applications

This symbol indicates special instructions for Ex applications.



### List

The dot set in front indicates a list with no implied sequence.



### Sequence of actions

Numbers set in front indicate successive steps in a procedure.



### Disposal

This symbol indicates special instructions for disposal.

## 2 For your safety

### 2.1 Authorised personnel

All operations described in this documentation must be carried out only by trained and authorized personnel.

During work on and with the device, the required personal protective equipment must always be worn.

### 2.2 Appropriate use

The B61-300 is an overvoltage arrester for sensors and signal conditioning instruments with mains voltage supply.

You can find detailed information about the area of application in chapter "*Product description*".

### 2.3 Warning about incorrect use

Inappropriate or incorrect use of this product can give rise to application-specific hazards, e.g. vessel overflow through incorrect mounting or adjustment. Damage to property and persons or environmental contamination can result. Also, the protective characteristics of the instrument can be impaired.

### 2.4 General safety instructions

This is a state-of-the-art instrument complying with all prevailing regulations and directives. The instrument must only be operated in a technically flawless and reliable condition. The operating company is responsible for the trouble-free operation of the instrument. When measuring aggressive or corrosive media that can cause a dangerous situation if the instrument malfunctions, the operating company has to implement suitable measures to make sure the instrument is functioning properly.

During the entire duration of use, the operating company is obliged to determine the compliance of the necessary occupational safety measures with the current valid rules and regulations and also take note of new regulations.

The safety instructions in this operating instructions manual, the national installation standards as well as the valid safety regulations and accident prevention rules must be observed.

For safety and warranty reasons, any invasive work on the device beyond that described in the operating instructions manual may be carried out only by personnel authorised by us. Arbitrary conversions or modifications are explicitly forbidden. For safety reasons, only the accessory specified by us must be used.

To avoid any danger, the safety approval markings and safety tips on the device must also be observed.

## **2.5 Installation and operation in the USA and Canada**

This information is only valid for USA and Canada. Hence the following text is only available in the English language.

Installations in the US shall comply with the relevant requirements of the National Electrical Code (NEC - NFPA 70) (USA).

Installations in Canada shall comply with the relevant requirements of the Canadian Electrical Code (CEC Part I) (Canada).

## 3 Product description

### 3.1 Configuration

#### Scope of delivery

The scope of delivery encompasses:

- Overvoltage arrester B61-300 (optionally integrated in housing with PE terminal)
- PE terminal for carrier rail
- Documentation
  - This operating instructions manual
  - If necessary, further certificates

#### Constituent parts

The following illustration shows the configuration of the overvoltage arrester B61-300:

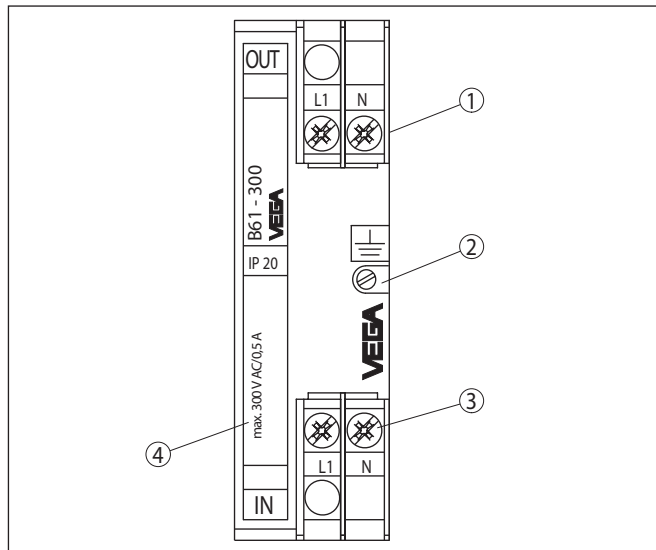

Fig. 1: Configuration of B61-300

- 1 Terminals Out (protected side)
- 2 Screw for carrier rail fastening
- 3 Terminals In (unprotected side)
- 4 Type label

### 3.2 Principle of operation

#### Application area

Voltage surges can be caused by indirect atmospheric discharges (lightning strokes) or switching operations in the supply network. Further causes can be inductive or capacitive couplings from other electrical systems. Voltage peaks (transients) must be expected especially when long power supply and signal cables are used.

Such voltage surges can cause damage to sensors and controllers.

The VEGA overvoltage arrester reduces voltage surges on the supply or signal cables to a safe level. They are designed for mounting on

carrier rail according to EN 50 022/EN 50 035 in the switching cabinet or in a metal or plastic housing close to the sensor.

**Functional principle**

Depending on the version, different combinations of protective elements for voltage limitation are used. Typical protective elements are suppressor diodes (diodes with special characteristics), varistors (voltage-dependent resistors) as well as overvoltage arresters (gas arresters).

As soon as the voltage increases to the response voltage of the protective element, the element becomes conductive and the energy is discharged to ground. After the overvoltage has subsided, the protective element returns to its high-impedance state and thus has no influence on the supply or signal circuit.

**3.3 Packaging, transport and storage**

**Packaging**

Your instrument was protected by packaging during transport. Its capacity to handle normal loads during transport is assured by a test based on ISO 4180.

The packaging consists of environment-friendly, recyclable cardboard. For special versions, PE foam or PE foil is also used. Dispose of the packaging material via specialised recycling companies.

**Transport**

Transport must be carried out in due consideration of the notes on the transport packaging. Nonobservance of these instructions can cause damage to the device.

**Transport inspection**

The delivery must be checked for completeness and possible transit damage immediately at receipt. Ascertained transit damage or concealed defects must be appropriately dealt with.

**Storage**

Up to the time of installation, the packages must be left closed and stored according to the orientation and storage markings on the outside.

Unless otherwise indicated, the packages must be stored only under the following conditions:

- Not in the open
- Dry and dust free
- Not exposed to corrosive media
- Protected against solar radiation
- Avoiding mechanical shock and vibration

**Storage and transport temperature**

- Storage and transport temperature see chapter "*Technical data - Ambient conditions*"
- Relative moisture 20 ... 85 %

## 4 Mounting instructions

### 4.1 Installation in switching cabinet

The overvoltage arrester is mounted in the switching cabinet on carrier rails according to EN 50 022 (DIN rail) or EN 50 035 (C-rail). It is fastened to the carrier rail with a screw located on its exterior. The screw is marked with the symbol for functional ground. Depending on the version, it may be galvanically connected to the ground terminal of the overvoltage arrester (see circuit diagram in chapter "Wiring plan").

The carrier rail must be connected (low impedance) to the potential equalization line (PA). The wire cross-section must be at least 2.5 mm<sup>2</sup>, the cable must be as short as possible.

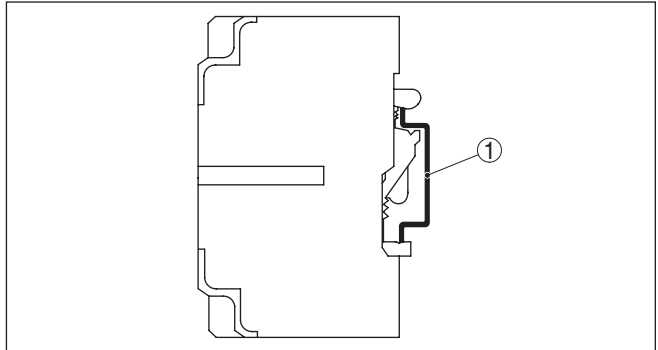

Fig. 2: Mounting on carrier rail according to EN 50 022 (DIN rail) 35 x 7.5 mm

1 Carrier rail

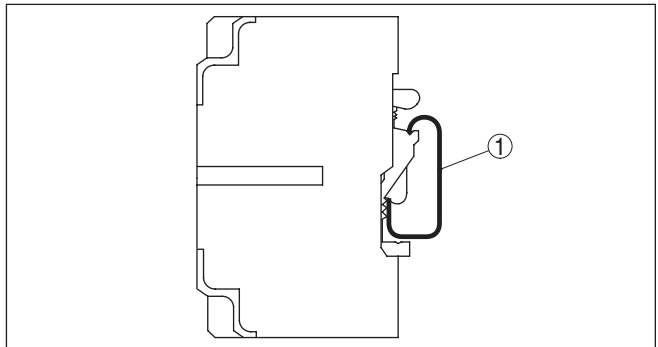

Fig. 3: Mounting on carrier rail according to EN 50 035 (C-rail) 35 x 7.5 mm

1 Carrier rail

#### Installation procedure

Proceed as follows:

1. Loosen fixing screw



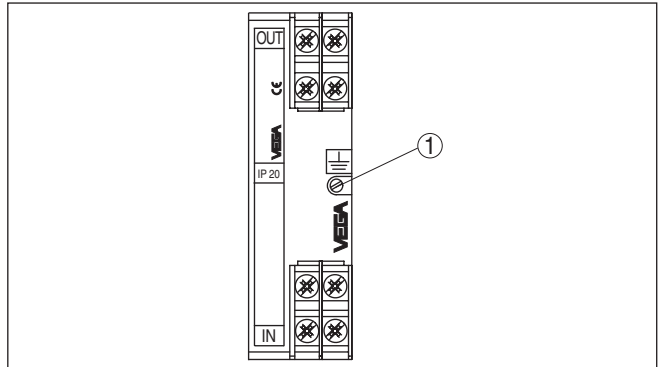

Fig. 4: Mounting on carrier rail

1 Fixing screw

2. Place the overvoltage arrester onto the rail and let it snap in
3. Tighten fixing screw

## 4.2 Mounting in housing

The overvoltage arrester is optionally available in a plastic or aluminium housing. Make sure when mounting that the cable glands point downward. Thus avoids water ingress.

The carrier rail inside the housing is galvanically connected to the ground terminal outside on the housing. For this function of the overvoltage arrester, this ground terminal must be connected (low impedance) with the potential equalization line (PA). The wire cross-section must be at least 2.5 mm<sup>2</sup>, the cable must be as short as possible.

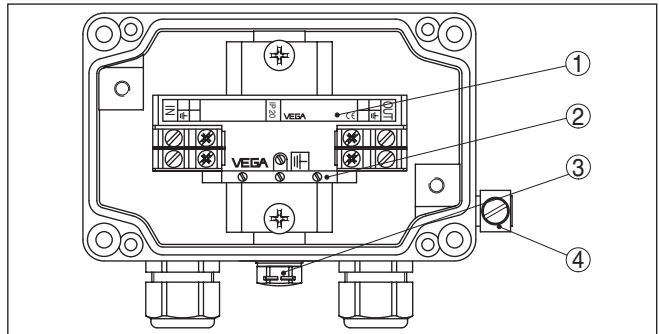

Fig. 5: Mounting in Aluminium housing

- 1 Overvoltage arrester
- 2 PE terminal
- 3 Pressure compensation
- 4 Ground terminal

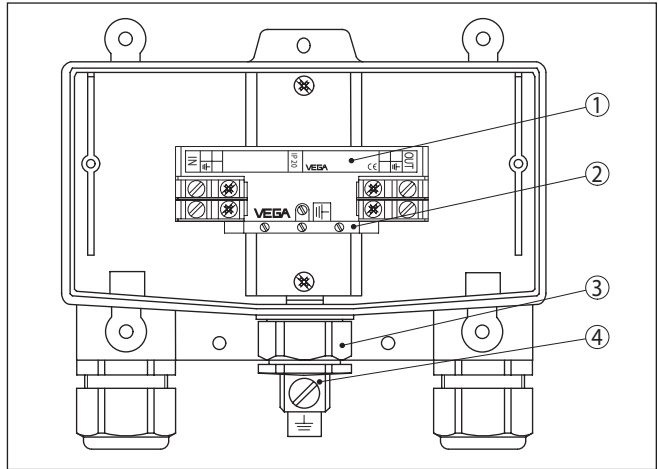

Fig. 6: Mounting in plastic housing

- 1 Overvoltage arrester
- 2 PE terminal
- 3 Pressure compensation
- 4 Ground terminal

## 5 Connecting to power supply

### 5.1 Preparing the connection

#### Note safety instructions

Always keep in mind the following safety instructions:

- Connect only in the complete absence of line voltage

Before starting setup make sure that the power supply corresponds to the specifications on the type label.

For effective overvoltage protection, the cables between overvoltage arrester and instrument should be as short as possible.



#### Danger:

Apart from the overvoltage arrester, a separate PE terminal is mounted on the carrier rail in the aluminium and plastic housing. It is galvanically connected with the carrier rail.

On the aluminium housing, the ground conductor (PE) of the power supply cable must be led to this PE terminal to reach protection ground for the metal housing.



#### Note:

Install a disconnecting device for the instrument which is easy to access. The disconnecting device must be marked for the instrument (IEC/EN 61010).

### 5.2 Connection steps for version with housing

Proceed as follows:

1. Loosen screws of the housing cover
2. Push the supply and connection cables through the cable gland into the housing, strip approx. 1 cm (0.4 in) insulation from the ends of the wires
3. Connect the wire ends L and N according to chapter "*Wiring plan*" to the terminals of the overvoltage arrester
4. Wire ends for PE to the green/yellow PE terminal in the housing
5. Connect the outer ground terminal on the housing to potential equalization
6. Check all cable connections, especially the PE and ground connection, to make sure they are tightened sufficiently
7. Tighten the compression nuts of the cable entry glands. The seal ring must completely encircle the cable
8. Tighten screws of the housing cover

The electrical connection is finished.

### 5.3 Wiring plan

#### Circuit diagram

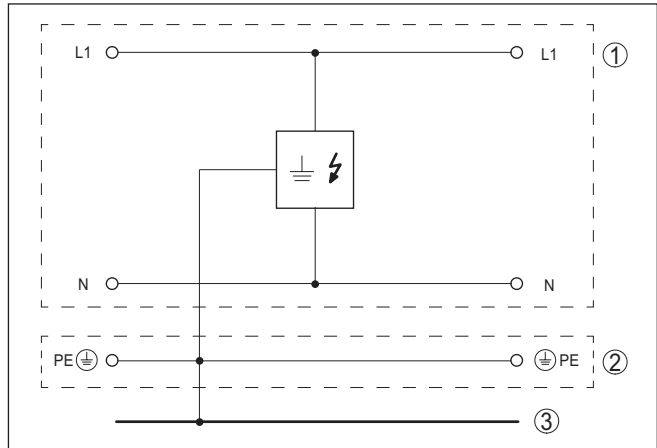

Fig. 7: Circuit diagram overvoltage arrester B61-300

- 1 Overvoltage protection
- 2 PE terminal
- 3 Potential equalization, plant-side

#### Wiring plan

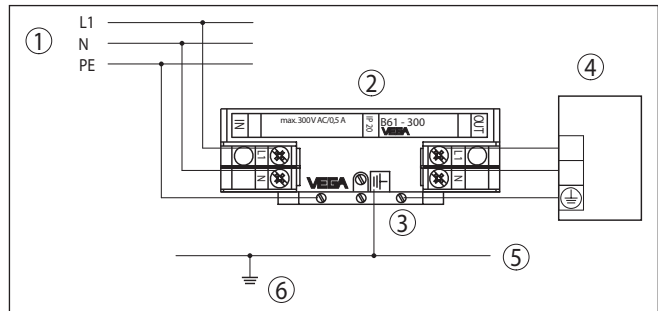

Fig. 8: Wiring plan overvoltage arrester B61-300 in the housing

- 1 Mains supply
- 2 Overvoltage protection
- 3 PE terminal
- 4 Protected instrument
- 5 Carrier rail
- 6 Potential equalisation

## 6 Diagnostics and servicing

### 6.1 Maintenance

#### Maintenance

If the device is used properly, no special maintenance is required in normal operation.

### 6.2 Rectify faults

#### Reaction when malfunction occurs

The operator of the system is responsible for taking suitable measures to rectify faults.

#### Causes of malfunction

Maximum reliability is ensured. Nevertheless, faults can occur during operation. These may be caused by the following, e.g.:

- Voltage supply
- Interference on the lines, contact problems

#### Fault rectification

The first measure to be taken is to check the input/output signal as well as the power supply. In many cases, the causes can be determined and faults can be quickly rectified.

#### Reaction after fault rectification

Depending on the reason for the fault and the measures taken, the steps described in chapter "Setup" must be carried out again or must be checked for plausibility and completeness.

#### 24 hour service hotline

Should these measures not be successful, please call in urgent cases the VEGA service hotline under the phone no. **+49 1805 858550**.

The hotline is also available outside normal working hours, seven days a week around the clock.

Since we offer this service worldwide, the support is provided in English. The service itself is free of charge, the only costs involved are the normal call charges.

### 6.3 How to proceed if a repair is necessary

On our homepage you will find detailed information on how to proceed in the event of a repair.

So that we can carry out the repair quickly and without queries, generate a instrument return form there with the data of your device.

The following is required:

- The serial number of the instrument
- A short description of the fault
- Details of the medium, if applicable

Print the generated instrument return form.

Clean the instrument and pack it damage-proof.

Send the printed instrument return form and possibly a safety data sheet together with the device.

You will find the address for the return on the generated instrument return form.

## 7 Dismount

### 7.1 Dismounting steps

Take note of chapters "*Mounting*" and "*Connecting to voltage supply*" and carry out the listed steps in reverse order.

### 7.2 Disposal



Pass the instrument on to a specialised recycling company and do not use the municipal collecting points.

Remove any batteries in advance, if they can be removed from the device, and dispose of them separately.

If personal data is stored on the old device to be disposed of, delete it before disposal.

If you have no way to dispose of the old instrument properly, please contact us concerning return and disposal.

## 8 Certificates and approvals

### 8.1 Conformity

The device complies with the legal requirements of the applicable country-specific directives or technical regulations. We confirm conformity with the corresponding labelling.

The corresponding conformity declarations can be found on our homepage.

### 8.2 Environment management system

Protection of the environment is one of our most important duties. That is why we have introduced an environment management system with the goal of continuously improving company environmental protection. The environment management system is certified according to DIN EN ISO 14001.

Help us to meet these requirements and observe the environmental instructions in the chapters "*Packaging, transport and storage*", "*Disposal*" of this instructions manual.

## 9 Supplement

### 9.1 Technical data

#### Note for approved instruments

The technical data in the respective safety instructions are valid for approved instruments (e.g. with Ex approval). In some cases, these data can differ from the data listed herein.

All approval documents can be downloaded from our homepage.

#### General data

Version	Device for carrier rail mounting
Housing material	Plastic (PPE)
Weight	approx. 175 g (0.385 lbs)

#### Electrical characteristics<sup>1)</sup>

Operating voltage	100 ... 300 V AC/DC
Max. permissible current	0.5 A
Internal resistance	< 0.01 $\Omega$
Response voltage	500 V
Response time	< 10 <sup>-6</sup> s
Discharge current	< 10 kA (8/20 $\mu$ s)

#### Electromechanical data

Screw terminals for cable cross-section	< 2.5 mm <sup>2</sup> (AWG 14)
---	--------------------------------

#### Ambient conditions

Ambient temperature	-40 ... +60 °C (-40 ... +140 °F)
Storage and transport temperature	-40 ... +70 °C (-40 ... +158 °F)

#### Electrical protective measures

Protection rating	
– unassembled	IP20
– In Aluminium or plastic housing	IP65
– IK code according to IEC 62262	IK06

<sup>1)</sup> Reference temperature +25 °C (+77 °F).



## 9.2 Dimensions B61-300

### Overvoltage protection

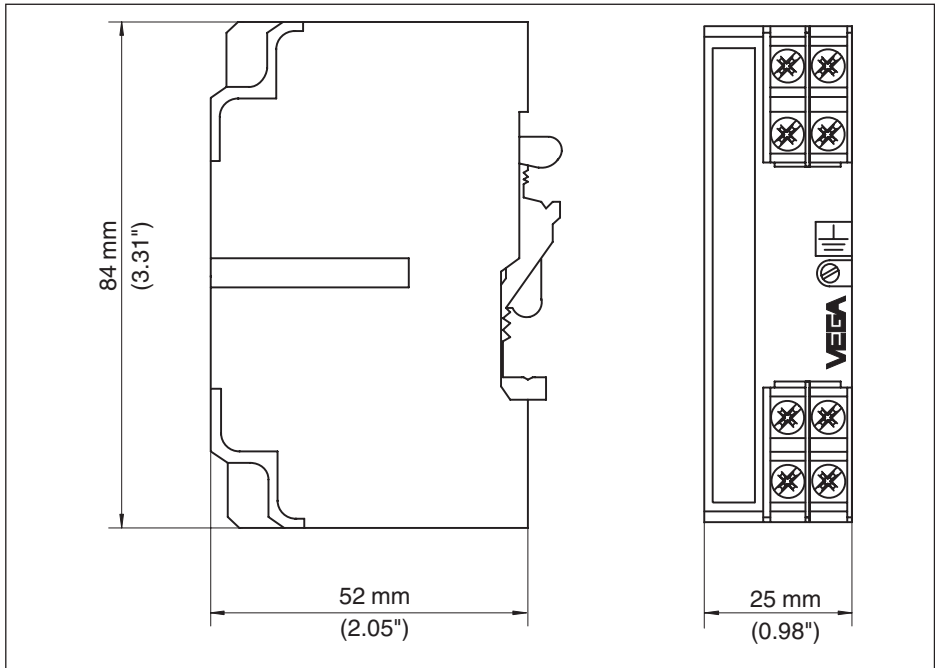

Fig. 9: Dimensions B61-300

Housing

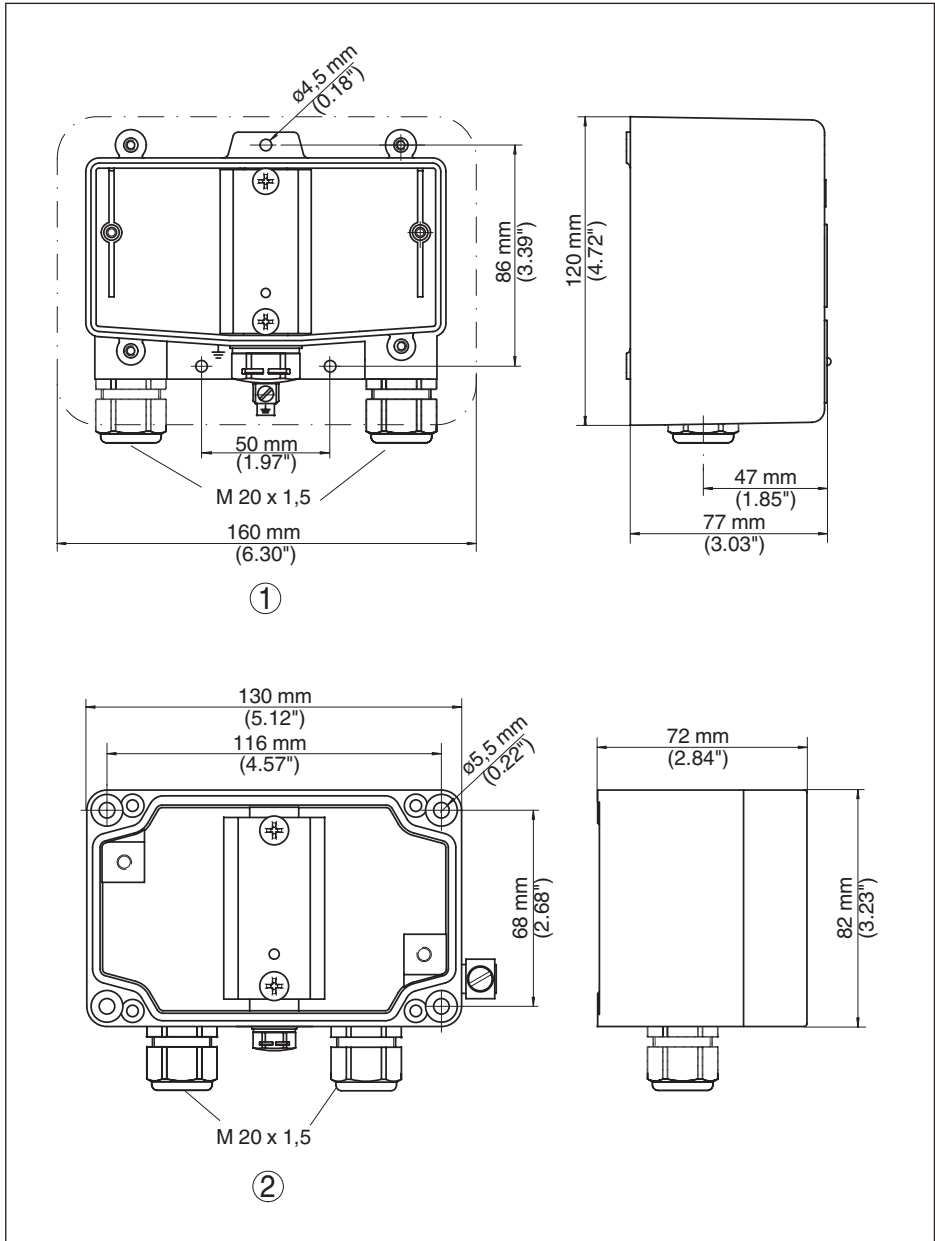

Fig. 10: Dimensions B61-300

- 1 Plastic housing
- 2 Aluminium housing

### 9.3 Industrial property rights

VEGA product lines are global protected by industrial property rights. Further information see [www.vega.com](http://www.vega.com).

VEGA Produktfamilien sind weltweit geschützt durch gewerbliche Schutzrechte.

Nähere Informationen unter [www.vega.com](http://www.vega.com).

Les lignes de produits VEGA sont globalement protégées par des droits de propriété intellectuelle. Pour plus d'informations, on pourra se référer au site [www.vega.com](http://www.vega.com).

VEGA líneas de productos están protegidas por los derechos en el campo de la propiedad industrial. Para mayor información revise la pagina web [www.vega.com](http://www.vega.com).

Линии продукции фирмы ВЕГА защищаются по всему миру правами на интеллектуальную собственность. Дальнейшую информацию смотрите на сайте [www.vega.com](http://www.vega.com).

VEGA系列产品在全球享有知识产权保护。

进一步信息请参见网站[www.vega.com](http://www.vega.com)。

### 9.4 Trademark

All the brands as well as trade and company names used are property of their lawful proprietor/originator.

A large grid of graph paper, consisting of 20 columns and 30 rows of small squares, intended for taking notes.

A large grid of graph paper for taking notes, consisting of 20 columns and 30 rows of small squares.

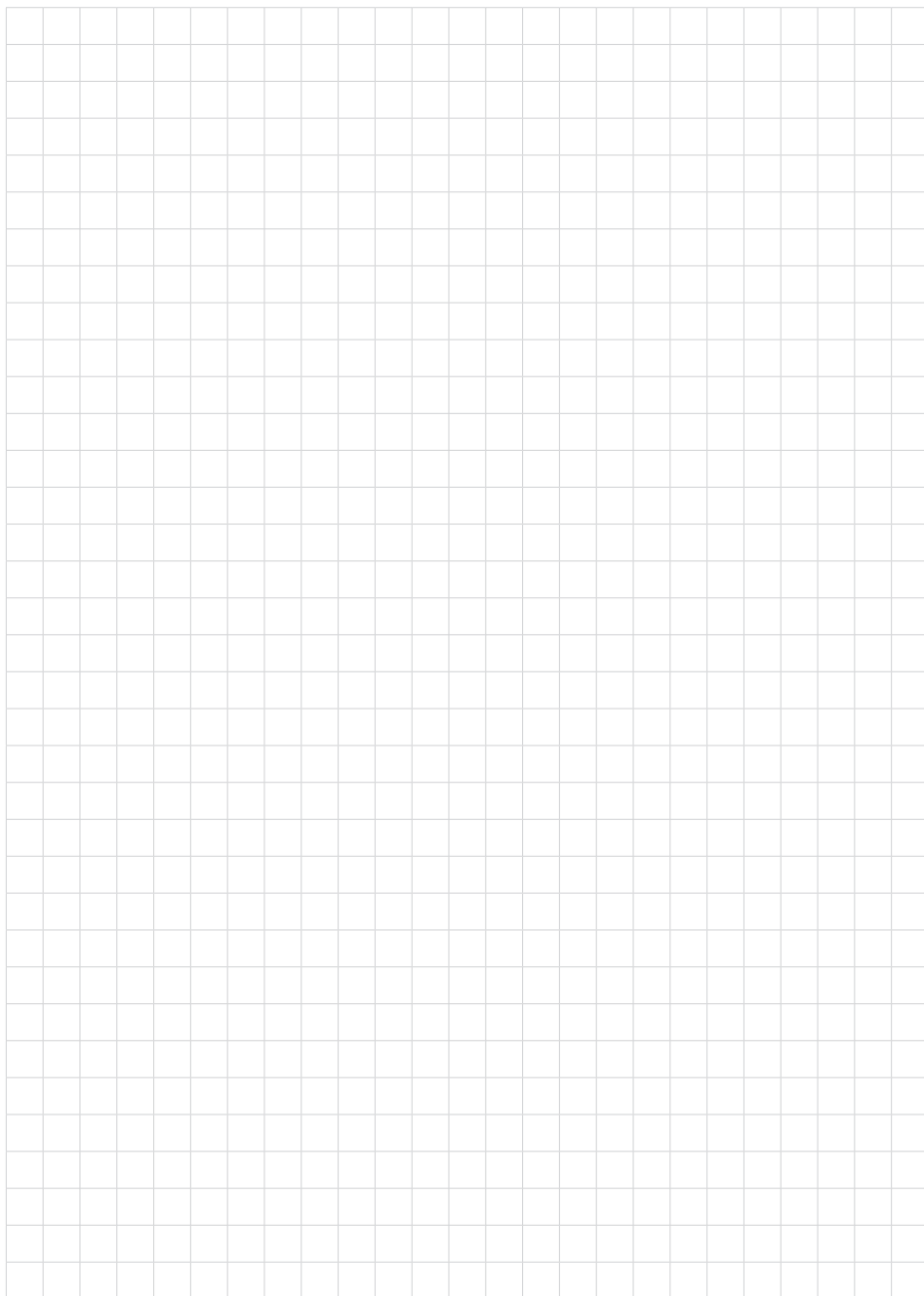

40488-EN-240422

A large grid of graph paper for taking notes, consisting of 20 columns and 30 rows of small squares.

Printing date:

**VEGA**

All statements concerning scope of delivery, application, practical use and operating conditions of the sensors and processing systems correspond to the information available at the time of printing.

Subject to change without prior notice

© VEGA Grieshaber KG, Schiltach/Germany 2024



40488-EN-240422

VEGA Grieshaber KG  
Am Hohenstein 113  
77761 Schiltach  
Germany

Phone +49 7836 50-0  
E-mail: [info.de@vega.com](mailto:info.de@vega.com)  
[www.vega.com](http://www.vega.com)