

Level and pressure instrumentation for yachts



Application examples and products



Instrumentation for yachts

This brochure presents examples of applied level and pressure measurement technology on board a yacht. Four example applications show which sensors are the most suitable for each respective measuring task.

- | | | |
|---|---|---|
| 1 | Fresh water and pool water tanks | Level measurement |
| 2 | Fuel tanks | Level measurement and point level detection |
| 3 | Bilges | Point level detection |
| 4 | Grey water and black water tanks | Level measurement and point level detection |

VEGA has over 50 years of experience in developing and manufacturing level and pressure measuring instruments.



Just give us a call. We're always happy to help and advise you on instrument selection.

For more information about our services and application solutions, visit our website at



www.vega.com/yacht-building

All sensors at a glance



Continuous level measurement

Instrument type		Measuring range	Process fitting	Process temperature	Process pressure
VEGAFLEX 81 TDR sensor for continuous level and interface measurement of liquids		up to 75 m	Thread from G $\frac{3}{4}$, $\frac{1}{2}$ NPT, flanges from DN 25, 1"	-60 ... +200 °C	-1 ... +40 bar (-100 ... +4000 kPa)
VEGASON 61 Ultrasonic sensor for continuous level measurement		up to 5 m	Thread G $\frac{1}{2}$, $\frac{1}{2}$ NPT	-40 ... +80 °C	-0.2 ... +2 bar (-20 ... +200 kPa)

Point level detection

Instrument type		Measuring range	Process fitting	Process temperature	Process pressure
VEGACAP 64 Capacitive rod electrode for level detection of adhesive products		up to 4 m	Thread from G $\frac{3}{4}$, $\frac{1}{2}$ NPT, flanges from DN 25, 1"	-50 ... +200 °C	-1 ... +64 bar (-100 ... +6400 kPa)
VEGASWING 51 Vibrating level switch for liquids		-	Thread from G $\frac{1}{2}$, $\frac{1}{2}$ NPT, hygienic fittings	-40 ... +150 °C	-1 ... +64 bar (-100 ... +6400 kPa)
VEGASWING 61 Vibrating level switch for liquids		-	Thread from G $\frac{3}{4}$, $\frac{1}{2}$ NPT, flanges from DN 25, 1", hygienic fittings	-50 ... +250 °C	-1 ... +64 bar (-100 ... +6400 kPa)

Pressure measurement

Instrument type		Deviation	Process fitting	Process temperature	Process pressure
VEGABAR 82 Pressure transmitter with ceramic measuring cell		0.2 % 0.1 % 0.05 %	Thread G $\frac{1}{2}$, $\frac{1}{2}$ NPT, flanges from DN 15, 1", hygienic fittings	-40 ... +150 °C	-1 ... +100 bar (-100 ... +10000 kPa)
VEGAWELL 52 Submersible pressure transmitter with ceramic measuring cell		0.1 % 0.2 %	Straining clamp, thread, suspension cable, threaded fitting of 316L, PVDF, Duplex, Titanium	-20 ... +80 °C	0 ... +60 bar (0 ... +6000 kPa)



Yacht building

Modern, service-proven instrumentation

VEGA is an experienced instrumentation outfitter for ships of all types and sizes. The company has decades of experience, especially with measurement technology on board yachts. VEGA sensors measure level and pressure in tanks and containers with exceptional accuracy and reliability.

Good value for money

VEGA sensors comply with the specific requirements in the shipbuilding sector and are tailor-made for yachts. Robust housing materials, high-quality FEP and PUR cables as well as shock and vibration resistant ceramic sensors guarantee long-term use.

Simple handling

VEGA sensors are really easy to connect, set up and put into operation. This makes installing and operating the instruments a breeze for the shipyard and the crew.

Classification

VEGA sensors are certified according to all major ship classifications such as ABS, BV, CCS, DNV, GL, LR and Rina.



Det Norske Veritas



Germanischer Lloyd



Bureau Veritas



Registro Italiano
Navale



China Classification
Society



Lloyd's Register
of Shipping



American Bureau
of Shipping

More information



plics® – easy is better

Instrument platform plics®

The plics® idea is simple: Each instrument is assembled from prefabricated components once the order is received. This modular design allows full flexibility when selecting the required sensor features. You receive your customised, user-friendly instrument within an amazingly short time. The best part: these instruments are more cost-effective and advantageous in every way – throughout their entire life cycle.

Display and adjustment

The display and adjustment module PLICSCOM is used for measured value indication, adjustment and diagnosis directly on the sensor. Its simple menu structure enables quick setup. Status messages are displayed in plain text. The optional Bluetooth feature allows wireless operation.

Connection

The VEGACONNECT connects your instrument to a PC via the USB interface. PLICSCOM with Bluetooth enables data transfer with wireless technology. The instruments are configured with the tried and trusted adjustment software PACTware and the appropriate DTM or with an app on a smartphone or tablet PC. For EDD-based systems we also offer graphics-driven EDDs.

Asset management and maintenance

The integrated self-monitoring function of plics® instruments permanently informs the user on the status of the instruments. Status messages allow proactive and cost-effective maintenance. All diagnostic data can be called up easily and quickly in plain text via the built-in memory functions.





Fresh water and pool water tanks

Reliable

Reliable measurement ensured even in chlorinated water

Cost effective

Accurate detection of water in all tanks

User friendly

Simple mounting and maintenance-free operation

Level measurement in fresh water and pool water tanks

Every yacht has different tanks on board for storing hot water, pool water and drinking water. For drinking water, an especially hygienic measuring system is required.



VEGAWELL 52

Hydrostatic level measurement in the water tank

- Oil-free, ceramic-capacitive CERTEC® measuring cell
- Installation from the top or side
- High overload resistance
- Double seal withstands cleaning with chemical agents



VEGABAR 82

Hydrostatic level measurement in the water tank

- On-site adjustment and display in one housing
- Oil-free, ceramic-capacitive CERTEC® measuring cell
- Side mounting

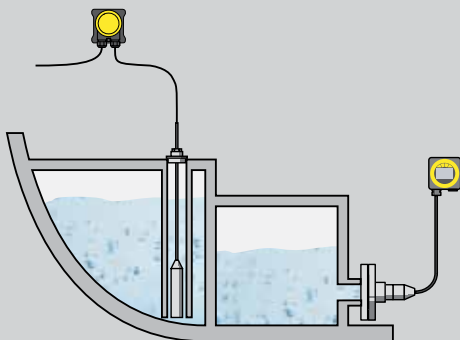



Fuel tanks

Reliable

Maximum safety for humans and the environment

Cost effective

Precise measurement in all fuel tanks

User friendly

Maintenance-free, reliable operation

Level measurement and point level detection in fuel tanks

The fuel tanks are some of the most important on board. They store a variety of fuels; diesel for the main engine and power generators, petrol for jet skis and dinghies, even aviation fuel for the helicopter. Level measurement ensures optimum availability of fuel at all times. An additional overfill protection system also ensures maximum safety for the environment.

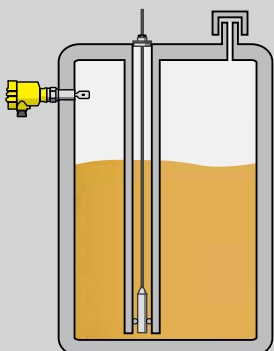
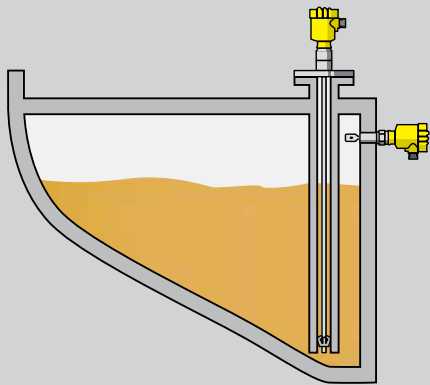

VEGAFLEX 81

Continuous level measurement with guided radar in the fuel tank

- Universally applicable for all media
- Precise level measurement under all process conditions
- Rod or cable design allows for easy installation



VEGAWELL 52

Hydrostatic level measurement in fuel tanks

- Rugged ceramic-capacitive CERTEC® measuring cell
- Simple installation from the top or side
- Highly chemically resistant FEP cable



VEGASWING 61

Vibrating level switch as overfill protection in the fuel tank

- Reliable detection of the level, regardless of media properties
- Simple side mounting
- Adjustment and maintenance-free operation



Bilges

Reliable

Maximum safety for humans and the environment

Cost effective

Simple installation

User friendly

Maintenance-free and reliable operation

Point level detection for bilge and leakage monitoring

Every ship has “bilges” – this is space at the lowest point of the vessel between the floor of the engine room and the bottom of the ship. A water/oil mixture collects in this bilge area, where the mixture is pumped out and recovered and separated into water and oil by an on-board skimmer and demulsifying unit. The bilge de-oiling equipment is normally controlled by level switches. The oil sumps of the main engine and any auxiliary systems must also be monitored continuously for safety and environmental reasons.



VEGASWING 51

Vibrating level switch for point level detection in bilge and oil pan

- Compact design allows installation in almost any position
- Maintenance-free operation, as the vibrating level switch has no mechanical moving parts
- Foam, bubble formation and viscosity do not influence switching accuracy

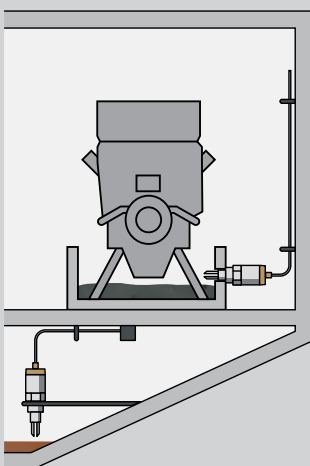



Grey water and black water tanks

Reliable

Precise level measurement
in abrasive and adhesive media

Cost effective

Low installation and integration
costs

User friendly

Maintenance-free operation

Level measurement and point level detection in grey and black water tanks

Wastewater accumulated on board is stored in grey or black water tanks up until its final disposal on land. The tanks are equipped with continuous level monitoring as well as point level detection to avoid overfilling.

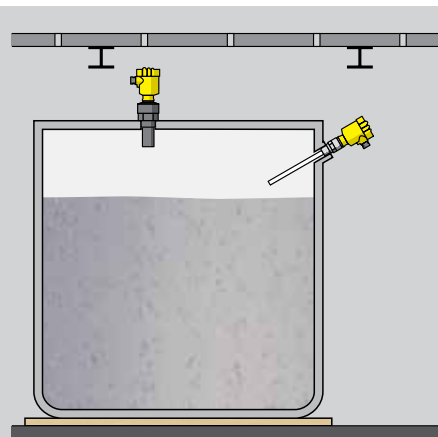
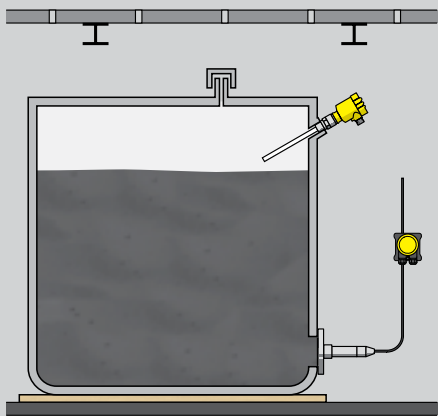

VEGAWELL 52

Hydrostatic level measurement in grey and black water tanks

- Abrasion resistant ceramic-capacitive CERTEC® measuring cell
- Measures reliably even with heavy soiling
- Simple mounting via threaded/flange fitting



VEGASON 61

Non-contact level measurement with ultrasound in grey and black water tank

- Reliable measurement in virtually all media
- Simple mounting from above
- Maintenance-free, as there is no contact with the medium



VEGACAP 64

Capacitive level switch for overflow protection in grey and black water tanks

- Probe fully insulated and immune to buildup, for adhesive and chemically aggressive media
- Reliable switching point, even with changing media
- Simple installation and setup



46825-EN-161201

VEGA Grieshaber KG
Am Hohenstein 113
77761 Schiltach
Germany

Phone +49 7836 50-0
Fax +49 7836 50-201
E-mail info.de@vega.com
www.vega.com

Looking Forward **VEGA**