



Safety instructions

VEGAFLEX 81, 82, 83, 86

Non-incendive Equipment

Two-wire 4 ... 20 mA/HART

Two-wire 4 ... 20 mA/HART with SIL qualification

Modbus

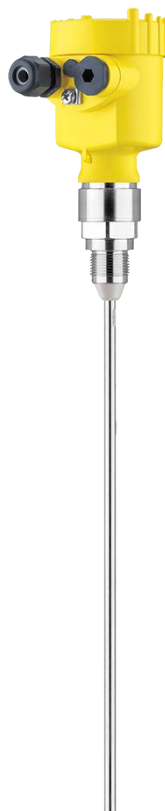

Document ID: 48191



VEGA

Contents

1	Area of applicability	3
2	Important specification in the type code	3
3	General information	11
4	Application area	11
5	Special operating conditions	11
6	Important information for mounting and maintenance	11
7	Safe operating mode	14
8	Potential equalization/Grounding	15
9	Electrostatic charging (ESD)	15
10	Electrical data	16
11	Mechanical data	16
12	Thermal data	17
13	Tensile force on the measuring cable/ rod	19

Supplementary documentation:

- Operating instructions VEGAFLEX 81, 82, 83, 86
- Quick setup guide VEGAFLEX 81, 82, 83, 86
- Certificate of Compliance CSA2012CA2515397X (Document ID: 49493)

Editing status: 2023-04-26

1 Area of applicability

These safety instructions apply to the VEGAFLEX 81, 82, 83, 86 of type series:

- VEGAFLEX FX8*(*).CA****A/H/UX****
- VEGAFLEX FX8*(*).CN****A/H/UX****

With the electronics versions:

- H - Two-wire 4 ... 20 mA/HART
- A - Two-wire 4 ... 20 mA/HART with SIL qualification
- U - Four-wire Modbus (converter in second chamber)

According to Certificate of Compliance CSA2012CA2515397X (certificate number on the type label) and for all instruments with safety instruction 48191.

The classification as well as the respective standards are stated in the Certificate of Conformity.

Type of protection marking:

- CL I, DIV 2, GP ABCD;
- CL II, III, DIV 2, GP FG T6 ... T1

2 Important specification in the type code

VEGAFLEX FX81(a).bcdefghijklm

Position		Feature	Description
a			One or two-digit alphanumeric variable, for production control. Optional, not safety-relevant.
b	Scope	C	cCSAus
c	Approval	A	CL I, DIV 2, GP ABCD; CL II, III, DIV 2, GP FG T6 ... T1
		N	CL I, DIV 2, GP ABCD; CL II, III, DIV 2, GP FG T6 ... T1 + Ship approval*

Position		Feature	Description
d	Version / Material	3	exchangeable coated cable (ø 4 mm) with uncoated centering weight / PFA and 316
		6	exchangeable rod (ø 8 mm) / Duplex (1.4462)
		7	exchangeable cable (ø 2 mm) with gravity weight / Alloy C276 (2.4819)
		A	exchangeable cable (ø 4 mm) with gravity weight / 316
		B	exchangeable cable (ø 2 mm) with gravity weight / 316
		C	exchangeable cable (ø 4 mm) with centering weight / 316
		D	exchangeable cable (ø 2 mm) with centering weight / 316
		E	exchangeable rod (ø 8 mm) / 316L
		F	exchangeable rod (ø 12 mm) / 316L
		G	exchangeable rod (ø 8 mm) / 304L
		H	Coax (ø 21.3 mm) with single hole / 304L
		I	exchangeable cable (ø 4 mm) with gravity weight / Alloy C22 (2.4602)
		J	exchangeable cable (ø 4 mm) with centering weight / Alloy C22 (2.4602)
		K	Coax (ø 21.3 mm) with single hole / 316L
		L	Coax (ø 21.3 mm) with multiple hole / 316L
		N	Coax (ø 21.3 mm) with multiple hole / 304L
		O	exchangeable rod (ø 12 mm) / Alloy C22 (2.4602)
		P	Coax (ø 42.2 mm) with multiple hole / 316L
		Q	Coax (ø 21.3 mm) with multiple hole / Alloy C22 (2.4602)
		R	Coax (ø 42.2 mm) with multiple hole / Alloy C22 (2.4602)
S	exchangeable rod (ø 8 mm) / Alloy C22 (2.4602)		
U	exchangeable cable (ø 4 mm) without weight / 316		
V	exchangeable rod (ø 12 mm) / Alloy 400 (2.4360)		
W	exchangeable rod (ø 8 mm) / Alloy C276 (2.4819)		
		*	further approved Versions / Materials
ef	Process fitting / Material	**	Two-digit alphanumeric variables for process fittings according to industry standard

Position		Feature	Description
g	Seal / Second line of defense / Process temperature	A	FKM (SHS EPM 70C3 GLT) / without / -40 ... +80 °C
		B	EPDM (A+P 70.10-02) / without / -40 ... +80 °C
		D	FFKM (Kalrez 6375) / without / -10 ... +150 °C
		D	FFKM (Kalrez 6375) / without / -20 ... +150 °C
		F	FKM (SHS FPM 70C3 GLT) / without / -40 ... +150 °C
		G	FKM (SHS FPM 70C3 GLT) / with / -40 ... +150 °C
		H	EPDM (A+P 70.10-02) / without / -40 ... +150 °C
		I	Silicone FEP coated (A+P FEP-O-SEAL) / without / -40 ... +150 °C
		J	Borosilicate glass for slightly volatile substances, e.g. ammonia / with / -60 ... +150 °C
		K	FFKM (Kalrez 6375) / without / -10 ... +200 °C
		K	FFKM (Kalrez 6375) / without / -20 ... +200 °C
		L	FFKM (Kalrez 6375) / with / -10 ... +200 °C
		L	FFKM (Kalrez 6375) / with / -20 ... +200 °C
		M	EPDM (A+P 70.10-02) / with / -40 ... +150 °C
		N	Silicone FEP coated (A+P FEP-O-SEAL) / with / -40 ... +150 °C
		O	Silicone FEP coated (A+P FEP-O-SEAL) / without / -40 ... +80 °C
		P	FFKM (Kalrez 6375) / with / -10 ... +150 °C
P	FFKM (Kalrez 6375) / with / -20 ... +150 °C		
*	Other seals suitable for process temperature, IP or NEMA protection and environmental conditions, see operating instructions.		
h	Electronics	A	Two-wire 4 ... 20 mA/HART with SIL qualification
		H	Two-wire 4 ... 20 mA/HART
		U	Four-wire Modbus (converter in second chamber)
i	Supplementary electronics	X	without
j	Housing / Protection	8	Stainless steel single chamber (electropolished) / IP66/IP68 (0.2 bar)
		A	Aluminium single chamber / IP66/IP68 (0.2 bar)
		D	Aluminium double chamber / IP66/IP68 (0.2 bar)
		H	Special colour Aluminium single chamber / IP66/IP68 (0.2 bar)
		S	Special colour Aluminium double chamber / IP66/IP68 (0.2 bar)
		V	Stainless steel single chamber (precision casting) / IP66/IP68 (0.2 bar)
		W	Stainless steel double chamber / IP66/IP68 (0.2 bar)

Position		Feature	Description
k	Cable entry / Connection	1	M20 x 1.5 / without
		D	M20 x 1.5 / Blind plug
		N	½ NPT / Blind plug
		Q	½ NPT / without
		*	Respectively approved cable glands and blind plugs correspond to the ignition protection type
l	Display and adjustment module PLICSCOM	X	without
		A	mounted
		F	without; lid with inspection window
		B	Laterally mounted
		K	mounted; with Bluetooth, magnetic pen operation
		L	laterally mounted; with Bluetooth, magnetic pen operation
m	Certificates	M	Yes
		X	No

VEGAFLEX FX82(a).bcdefghijklm

Position		Feature	Description
a			One or two-digit alphanumeric variable, for production control. Optional, not safety-relevant.
b	Scope	C	cCSAus
c	Approval	A	CL I, DIV 2, GP ABCD; CL II, III, DIV 2, GP FG T6 ... T1
		N	CL I, DIV 2, GP ABCD; CL II, III, DIV 2, GP FG T6 ... T1 + Ship approval*
d	Version / Material	A	exchangeable cable (ø 4 mm) / 316
		F	exchangeable rod (ø 6 mm) / 316
		E	exchangeable steel cable (ø 6 mm with gravity weight / PA coated)
		G	exchangeable steel cable (ø 11 mm with gravity weight / PA coated)
		H	exchangeable rod (ø 16 mm) / 316L
		T	exchangeable rod (ø 16 mm) / Alloy C22 (2.4602)
		*	further approved Versions / Materials
ef	Process fitting / Material	**	Two-digit alphanumeric variables for process fittings according to industry standard
g	Seal / Process temperature	F	FKM (SHS FPM 70C3 GLT) / -40 ... +150 °C
		H	EPDM (A+P 70.10-02) / -40 ... +150 °C
		K	FFKM (Kalrez 6375) / -20 ... +200 °C
		*	Other seals suitable for process temperature, IP or NEMA protection and environmental conditions, see operating instructions.

Position		Feature	Description
h	Electronics	A	Two-wire 4 ... 20 mA/HART with SIL qualification
		H	Two-wire 4 ... 20 mA/HART
		U	Four-wire Modbus (converter in second chamber)
i	Supplementary electronics	X	without
j	Housing / Protection	8	Stainless steel single chamber (electropolished) / IP66/IP68 (0.2 bar)
		A	Aluminium single chamber / IP66/IP68 (0.2 bar)
		D	Aluminium double chamber / IP66/IP68 (0.2 bar)
		H	Special colour Aluminium single chamber / IP66/IP68 (0.2 bar)
		S	Special colour Aluminium double chamber / IP66/IP68 (0.2 bar)
		V	Stainless steel single chamber (precision casting) / IP66/IP68 (0.2 bar)
		W	Stainless steel double chamber / IP66/IP68 (0.2 bar)
k	Cable entry / Connection	1	M20 x 1.5 / without
		D	M20 x 1.5 / Blind plug
		N	½ NPT / Blind plug
		Q	½ NPT / without
		*	Respectively approved cable glands and blind plugs correspond to the ignition protection type
l	Display and adjustment module PLICSCOM	X	without
		A	mounted
		F	without; lid with inspection window
		B	Laterally mounted
		K	mounted; with Bluetooth, magnetic pen operation
		L	laterally mounted; with Bluetooth, magnetic pen operation
m	Certificates	M	Yes
		X	No

VEGAFLEX FX83(a).bcdefghijklm

Position		Feature	Description
a			One or two-digit alphanumeric variable, for production control. Optional, not safety-relevant.
b	Scope	C	cCSAus
c	Approval	A	CL I, DIV 2, GP ABCD; CL II, III, DIV 2, GP FG T6 ... T1
		N	CL I, DIV 2, GP ABCD; CL II, III, DIV 2, GP FG T6 ... T1 + Ship approval*

Position		Feature	Description
d	Version / Material	B	exchangeable cable (ø 4 mm) with gravity weight / PFA
		F	exchangeable rod (ø 8 mm) / 1.4435 (BN2), (Ra<0,76µm)
		G	exchangeable rod (ø 8 mm) / 1.4435 (BN2), can be autoclaved (Ra<0,76µm)
		E	Rod (ø 10 mm) / PFA
		H	exchangeable rod (ø 8 mm) / 1.4435 (BN2), electropolished (Ra<0,38µm)
		I	exchangeable rod (ø 8 mm) / 1.4435 (BN2), electropolished, can be autoclaved (Ra<0,38µm)
		*	further approved Versions / Materials
ef	Process fitting / Material	**	Two-digit alphanumeric variables for process fittings according to industry standard
g	Seal / Process temperature	X	without / -40 ... +150 °C
		E	FFKM (Kalrez 6221) / -20 ... +150 °C
		C	EPDM (Freudenberg 70, EPDM 291) / -20 ... +130 °C
		T	FEPM (Vi 602 Extreme-ETP, COG) / -10 ... +150 °C
		*	Other seals suitable for process temperature, IP or NEMA protection and environmental conditions, see operating instructions.
h	Electronics	A	Two-wire 4 ... 20 mA/HART with SIL qualification
		H	Two-wire 4 ... 20 mA/HART
		U	Four-wire Modbus (converter in second chamber)
i	Supplementary electronics	X	without
j	Housing / Protection	8	Stainless steel single chamber (electropolished) / IP66/IP68 (0.2 bar)
		A	Aluminium single chamber / IP66/IP68 (0.2 bar)
		D	Aluminium double chamber / IP66/IP68 (0.2 bar)
		H	Special colour Aluminium single chamber / IP66/IP68 (0.2 bar)
		S	Special colour Aluminium double chamber / IP66/IP68 (0.2 bar)
		V	Stainless steel single chamber (precision casting) / IP66/IP68 (0.2 bar)
		W	Stainless steel double chamber / IP66/IP68 (0.2 bar)
k	Cable entry / Connection	1	M20 x 1.5 / without
		D	M20 x 1.5 / Blind plug
		N	½ NPT / Blind plug
		Q	½ NPT / without
		*	Respectively approved cable glands and blind plugs correspond to the ignition protection type

Position		Feature	Description
i	Display and adjustment module PLICSCOM	X	without
		A	mounted
		F	without; lid with inspection window
		B	Laterally mounted
		K	mounted; with Bluetooth, magnetic pen operation
		L	laterally mounted; with Bluetooth, magnetic pen operation
m	Certificates	M	Yes
		X	No

VEGAFLEX FX86(a).bcdefghijklm

Position		Feature	Description
a			One or two-digit alphanumeric variable, for production control. Optional, not safety-relevant.
b	Scope	C	cCSAus
c	Approval	A	CL I, DIV 2, GP ABCD; CL II, III, DIV 2, GP FG T6 ... T1
		N	CL I, DIV 2, GP ABCD; CL II, III, DIV 2, GP FG T6 ... T1 + Ship approval*
d	Version / Material	4	Coax (ø 42.2 mm) with multiple hole and reference distance / 316L
		5	Coax (ø 42.2 mm) with multiple hole and reference distance / Alloy C22 (2.4602)
		6	exchangeable rod (ø 8 mm) / Duplex (1.4462)
		A	exchangeable cable (ø 4 mm) with gravity weight / 316
		B	exchangeable cable (ø 2 mm) with gravity weight / 316
		C	exchangeable cable (ø 4 mm) with centering weight / 316
		D	exchangeable cable (ø 2 mm) with centering weight / 316
		E	exchangeable rod (ø 8 mm) / 316L
		H	exchangeable rod (ø 16 mm) / 316L
		I	exchangeable cable (ø 4 mm) with gravity weight / Alloy C22 (2.4602)
		J	exchangeable cable (ø 4 mm) with centering weight / Alloy C22 (2.4602)
		L	Coax (ø 21.3 mm) with multiple hole / 316L
		P	Coax (ø 42.2 mm) with multiple hole / 316L
		R	Coax (ø 42.2 mm) with multiple hole / Alloy C22 (2.4602)
		T	exchangeable rod (ø 16 mm) / Alloy C22 (2.4602)
		W	exchangeable rod (ø 8 mm) / Alloy C276 (2.4819)
*	further approved Versions / Materials		
ef	Process fitting / Material	**	Two-digit alphanumeric variables for process fittings according to industry standard

Position		Feature	Description
g	Seal / Second line of defense / Process temperature	1	Ceramic-graphite / with / -196 ... +280 °C
		2	Ceramic-graphite / with / -196 ... +400 °C
		2	Ceramic-graphite / with / -196 ... +450 °C
		3	PEEK-FFKM (Kalrez 6375) / with / -20 ... +250 °C
		*	Other seals suitable for process temperature, IP or NEMA protection and environmental conditions, see operating instructions.
h	Electronics	A	Two-wire 4 ... 20 mA/HART with SIL qualification
		H	Two-wire 4 ... 20 mA/HART
		U	Four-wire Modbus (converter in second chamber)
i	Supplementary electronics	X	without
j	Housing / Protection	8	Stainless steel single chamber (electropolished) / IP66/IP68 (0.2 bar)
		A	Aluminium single chamber / IP66/IP68 (0.2 bar)
		D	Aluminium double chamber / IP66/IP68 (0.2 bar)
		H	Special colour Aluminium single chamber / IP66/IP68 (0.2 bar)
		S	Special colour Aluminium double chamber / IP66/IP68 (0.2 bar)
		V	Stainless steel single chamber (precision casting) / IP66/IP68 (0.2 bar)
		W	Stainless steel double chamber / IP66/IP68 (0.2 bar)
k	Cable entry / Connection	1	M20 x 1.5 / without
		D	M20 x 1.5 / Blind plug
		N	½ NPT / Blind plug
		Q	½ NPT / without
		*	Respectively approved cable glands and blind plugs correspond to the ignition protection type
l	Display and adjustment module PLICSCOM	X	without
		A	mounted
		F	without; lid with inspection window
		B	Laterally mounted
		K	mounted; with Bluetooth, magnetic pen operation
		L	laterally mounted; with Bluetooth, magnetic pen operation
m	Certificates	M	Yes
		X	No

* The ship approval is not part of CSA2012CA2515397X.

Multiple listed characteristics according to the dependencies of the device configuration.

In the following, all above mentioned versions are called VEGAFLEX 81, 82, 83, 86. If parts of these safety instructions refer only to certain versions, then these will be mentioned explicitly with their type code.

3 General information

The level measuring instruments VEGAFLEX 81, 82, 83, 86 as guided radar sensors are used to detect the distance between medium surface and sensor by means of high frequency electromagnetic waves in the GHz range. The electronics uses the running time of the signals reflected by the medium surface to calculate the distance to the medium surface.

The VEGAFLEX 81, 82, 83, 86 consist of an electronics housing, a process connection element and a sensor, i.e. a measuring cable or a measuring rod. As an option, the display and adjustment module can also be installed in the instrument.

4 Application area

The VEGAFLEX 81, 82, 83, 86 are suitable for use in Class I and Class II in explosive atmospheres of all flammable substances of explosion groups A, B, C, D and dust groups F, G, which require DIV2 instruments.

The VEGAFLEX 81, 82, 83, 86 are suitable for applications in class III.

If the VEGAFLEX 81, 82, 83, 86 are installed and operated in hazardous areas, the general Ex installation regulations, National Electrical Code, further national and regional regulations as well as these safety instructions must be observed.

5 Special operating conditions

The following overview is listing all special properties of VEGAFLEX 81, 82, 83, 86, which make a labelling with the symbol "X" behind the certificate number necessary.

Electrostatic charging (ESD)

You can find the details in chapter "*Electrostatic charging (ESD)*" of these safety instructions.

Ambient temperature

You can find the details in chapter "*Thermal data*" of these safety instructions.

Impact and friction sparks

The VEGAFLEX 81, 82, 83, 86 in light metal versions (e.g. aluminium, titanium, zircon) must be mounted in such a way that sparks from impact and friction between light metals and steel (except stainless steel, if the presence of rust particles can be excluded) cannot occur.

Non-grounded, metallic parts

The resistance between aluminium housing to metal measuring point identification plate is $> 10^9$ Ohm.

The capacitance of the metal measuring point identification plate was measured as follows:

Measurement loop identification label	Capacitance
45 x 23 mm (standard)	21 pF
100 x 30 mm	52 pF
73 x 47 mm	61 pF

6 Important information for mounting and maintenance

General instructions

The following requirements must be fulfilled for mounting, electrical installation, setup and maintenance of the instrument:

- The staff must be qualified according the respective tasks
- The staff must be trained in explosion protection

- The staff must be familiar with the relevant valid regulations which are necessary for the safe installation and operation of the device.
- Make sure when working on the instrument (mounting, installation, maintenance) that there is no explosive atmosphere present, the supply circuits should be voltage-free, if possible
- The instrument has to be mounted according to the manufacturer specifications, the Certificate of Conformity, National Electrical Code and the valid regulations and standards
- Modifications on the instrument can influence the explosion protection and hence the safety, therefore repairs are not permitted to be conducted by the end user
- Modifications must only be carried out by employees authorized by VEGA company
- Use only approved spare parts
- Components for installation and connection not included in the approval documents are only permitted if these correspond technically to the latest standard mentioned on the cover sheet. They must be suitable for the application conditions and have a separate certificate. The special conditions of the components must be noted and if necessary, the components must be integrated in the type test. This applies also to the components already mentioned in the technical description.
- Vessel installations and probable flow must be taken into account

Cable and wire entries

- The VEGAFLEX 81, 82, 83, 86 must be connected via suitable cable gland or conduit systems that are in conformity with the requirements of the type of protection and the IP protection or NEMA rating and provided with a separate type approval certificate. When connecting VEGAFLEX 81, 82, 83, 86 to conduit systems, the corresponding sealing facility must be connected directly to the housing.
- The red thread or/dust covers screwed in when the instruments are shipped (depending on the version) must be removed before setup and replaced by approved cable entries or closing screws suitable for the respective ignition protection type and IP protection or NEMA rating.
- Note type and size of the thread: A label with the respective thread name is in the area of the respective thread
- Threads must have no damages
- Cable entries and closing screws should be mounted correctly and according to the safety instructions of the manufacturer to ensure the specified ignition protection type and IP protection rating or NEMA rating. When using certified or suitable cable glands, closing screws or plug connections, it is absolutely necessary to note the corresponding certificates/documents. Supplied cable entries or closing screws meet these requirements.
- Unused openings must be closed with plugs suitable for the ignition protection type and IP protection or NEMA rating. Supplied plugs meet these requirements.
- Cable or wire entries resp. the closing screws must be tightly screwed into the housing
- The connection cables resp. pipeline sealing facilities must be suitable for the application conditions (e.g. temperature range) of the application
- With surface temperatures > 70 °C, the cables must be suitable for the higher application conditions
- The connection cable of VEGAFLEX 81, 82, 83, 86 has to be wired fix and in such a way that damages can be excluded.

Mounting

When installing the device, observe the following:

- The instrument must be connected to the grounding system (via the process fitting or an external grounding clamp)
- Mechanical damage on the instrument must be avoided
- Impact and friction sparks are to be avoided

With single-chamber housing versions, the lid must be screwed in to the stop and secured with the

locking device before setup and use of VEGAFLEX 81, 82, 83, 86 in hazardous atmospheres.

With double-chamber housing versions, the lid of the connection compartment and the lid of the electronics compartment must be screwed in to the stop and secured with the corresponding locking device before setup and use of VEGAFLEX 81, 82, 83, 86 in hazardous atmospheres.

Single chamber housing

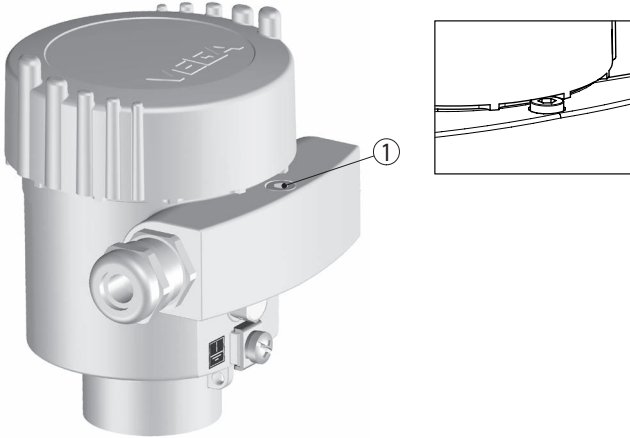

1 Locking screw of the lid

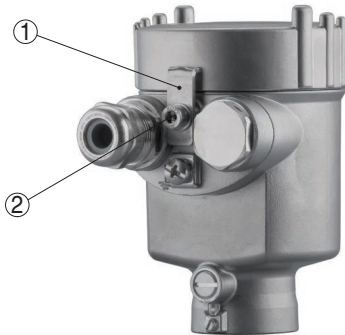

1 Bracket
2 Locking screw of the lid

Double chamber housing with explosion proof connection compartment

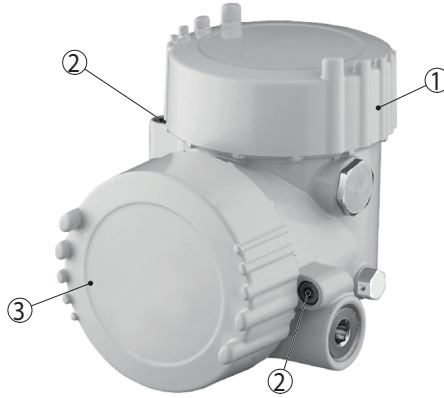

- 1 Connection compartment with electronics module
- 2 Locking screw of the lid
- 3 Explosion proof connection compartment with integrated barrier

Maintenance

To ensure the functionality of the device, periodic visual inspection is recommended for:

- Secure mounting
- No mechanical damages or corrosion
- Worn or otherwise damaged cables
- No loose connections of the line connections, equipotential bonding connections
- Correct and clearly marked cable connections

The parts of the VEGAFLEX 81, 82, 83, 86 being in contact with flammable media during operation must be included in the periodic overpressure test of the plant.

Version with exchangeable cable or rod probe

Only original VEGA cable or rod probes must be mounted to VEGAFLEX 81, 82, 83, 86. When mounting cable or rod probes, the torques specified in the respective operating instruction manuals must be maintained. The mechanical connection must be ensured.

7 Safe operating mode

General operating conditions

- Do not operate the instrument outside the electrical, thermal and mechanical specifications of the manufacturer
- Use the instrument only in media against which the wetted parts are sufficiently resistant
- To assess and reduce the explosion risk, the National Electrical Code applicable regulations, rules and standards must be taken into account
- Note the relation between process temperature on the sensor/antenna and the permissible ambient temperature on the electronics housing. For permissible temperatures, see the respective temperature tables. See chapter "Thermal data".
- If necessary, a suitable overvoltage arrester can be connected in front of the VEGAFLEX 81, 82, 83, 86
- Lids must not be opened if there is an explosive atmosphere.

Connection conditions

The connection cable of VEGAFLEX 81, 82, 83, 86 has to be wired fix and in such a way that damages can be excluded

If the temperature at the entry parts exceeds 70 °C, temperature-resistant connection cables must be used

8 Potential equalization/Grounding

- Integrate the instruments into the local potential equalisation, e.g. via the internal or external earth terminal
- The potential equalization terminal must be secured against loosening and twisting
- If grounding of the cable screening is necessary, this must be carried out acc. to the valid standards and regulations
- The intrinsically safe input and the intrinsically safe output circuits are ground-free. The voltage resistance against ground is min. 500 Veff.

9 Electrostatic charging (ESD)

In case of instrument versions with electrostatically chargeable plastic parts, the danger of electrostatic charging and discharging must be taken into account!

The following parts can charge and discharge:

- Lacquered housing version or alternative special lacquering
- Plastic housing, plastic housing parts
- Metal housing with inspection window
- Plastic process fittings
- Plastic-coated process fittings and/or plastic-coated sensors
- Connection cable for separate versions
- Type label
- Isolated metallic labels (measuring point identification plate)

Take note in case of danger of electrostatic charges:

- Avoid friction on the surfaces
- Do not dry clean the surfaces

The instruments must be mounted/installed in such a way that the following can be ruled out:

- electrostatic charges during operation, maintenance and cleaning.
- process-related electrostatic charges, e.g. by measuring media flowing past

The warning label indicates danger:



WARNING -- POTENTIAL ELECTROSTATIC CHARGING
HAZARD -- SEE INSTRUCTIONS

AVERTISSEMENT -- DANGER POTENTIEL DE CHARGES
ÉLECTROSTATIQUES -- VOIR INSTRUCTIONS

10 Electrical data

VEGAFLEX FX8^(*).CA/N****A/H****, single chamber housing

Signal circuit in the electronics and connection compartment, single chamber housing:	
Terminals 1[+], 2[-]	For connection to a certified, intrinsically safe circuit. U = 15 ... 35 V DC U _m = 253 V

VEGAFLEX FX8^(*).CA/N****A/H****, double chamber housing

Signal circuit in the connection compartment of the double chamber housing:	
Terminals 1[+], 2[-]	For connection to a certified, intrinsically safe circuit. U = 15 ... 35 V DC U _m = 253 V

Display and adjustment circuit:	
Terminals 5, 6, 7, 8	For connection to the circuit of the passive display unit VEGADIS 81.

Display and adjustment circuit:	
Spring contacts in the connection compartment	Only for connection to the display and adjustment module PLICSCOM.

VEGAFLEX FX8^(*).CA/N****U****

Supply circuit in the connection compartment of the double chamber housing:	
Terminals 1[+], 2[-]	U = 8 ... 32 V DC U _m = 253 V AC

Signal circuit in the connection compartment of the double chamber housing:	
Terminals 3[D0(+)], 4[D1(-)]	U _{max} = 5 V U _m = 253 V AC
USB connection:	U _{max} = 5 V

The electronics of VEGAFLEX 81, 82, 83, 86 is floating.

The metallic parts of VEGAFLEX 81, 82, 83, 86 are electrically connected with the earth terminals.

11 Mechanical data

The following mechanical data are valid for all housing and electronics versions.

Mechanical data	
Ground terminal (connection cross-section)	≥ 4 mm ²
Overtoltage category	See operating instructions VEGAFLEX 81, 82, 83, 86, chapter "Technical data"

Mechanical data	
Pollution degree	2
<ul style="list-style-type: none"> ● Materials ● Max. tensile load on the cable or rod probe ● Potential connections and electrical separating measures in the instrument ● Electromechanical data ● Electrical protective measures 	Are described in the operating instructions VEGAFLEX 81, 82, 83, 86 in chapter "Technical data".

12 Thermal data

The following temperature tables are valid for all housing and electronics versions.

Temperature class	Ambient temperature range (Electronics/housing)	Product temperature range on the sensor (measuring cable, rod)
T6	-40 ... +60 °C	-60 ... +80 °C
T5	-40 ... +60 °C	-60 ... +100 °C
T4	-40 ... +60 °C	-60 ... +135 °C
T3	-40 ... +60 °C	-60 ... +200 °C
T2	-40 ... +60 °C	-60 ... +300 °C
T1	-40 ... +60 °C	-60 ... +450 °C

Low temperature version up to -196 °C

Temperature class	Ambient temperature range (Electronics/housing)	Product temperature range on the sensor (measuring cable, rod)
T6	-40 ... +60 °C	-196 ... +80 °C
T5	-40 ... +60 °C	-196 ... +100 °C
T4	-40 ... +60 °C	-196 ... +135 °C
T3	-40 ... +60 °C	-196 ... +200 °C
T2	-40 ... +60 °C	-196 ... +300 °C
T1	-40 ... +60 °C	-196 ... +450 °C

If there is no explosive atmosphere, the permissible operating temperatures and pressures must be taken from the manufacturer specifications (operating instructions).

If the sensors (measuring cable, measuring rod) are operated at temperatures higher than those listed in the table above, measures must be taken to prevent the risk of ignition from hot surfaces.

The maximum permissible temperature at the electronics/housing must not exceed the values in the above table.

Temperature derating for process temperatures up to +150 °C, +200 °C, +250 °C, +280 °C and +450 °C

Versions for process temperatures up to +150 °C with metal housing

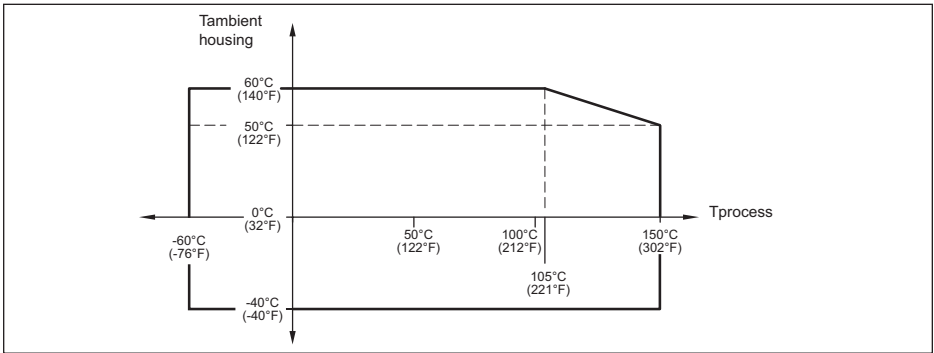

Versions for process temperatures up to +200 °C with metal housing

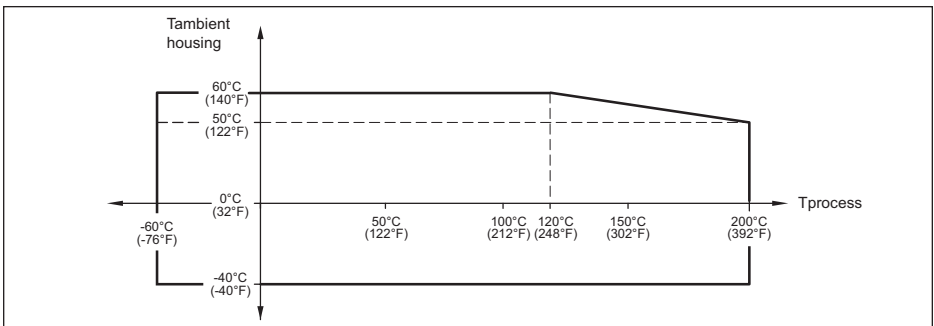

Versions for process temperatures up to +250 °C with metal housing

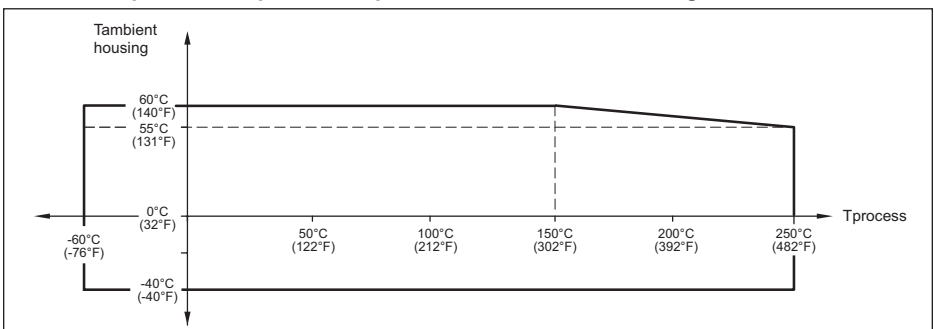

Versions for process temperatures up to +280 °C with metal housing

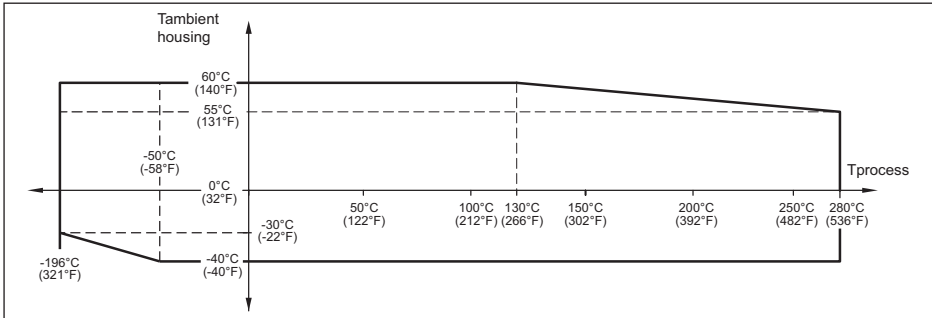

Versions for process temperatures up to +450 °C with metal housing

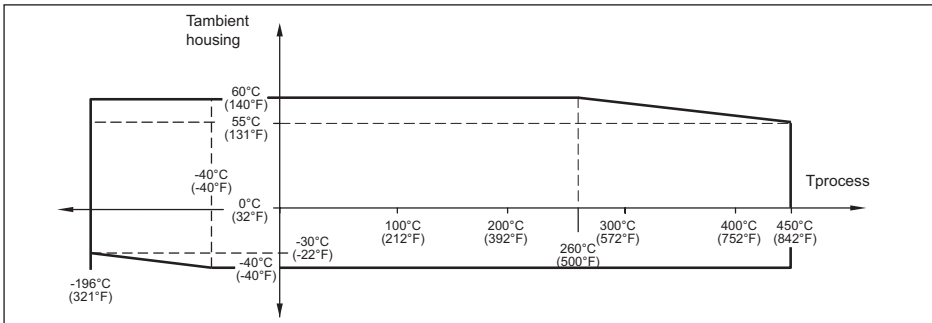

13 Tensile force on the measuring cable/ rod

The permissible tensile force is

- VEGAFLEX FX81(*).CA/N****A/H/UX****
 - Diameter 4 mm: F = 2.5 kN
 - Diameter 2 mm: F = 1.5 kN
- VEGAFLEX FX82.CA/N****A/H/UX****
 - Diameter 4 mm: F = 12 kN
 - Diameter 6 mm coated: F = 8 kN
 - Diameter 6 mm: F = 30 kN
 - Diameter 11 mm coated: F = 30 kN
- VEGAFLEX FX83.CA/N****A/H/UX****
 - Diameter 4 mm: F = 2 kN
 - Exchangeable rod: F = 4.5 kN
- VEGAFLEX FX86.CA/N****A/H/UX****
 - Diameter 4 mm: F = 2.5 kN
 - Diameter 2 mm: F = 1.5 kN

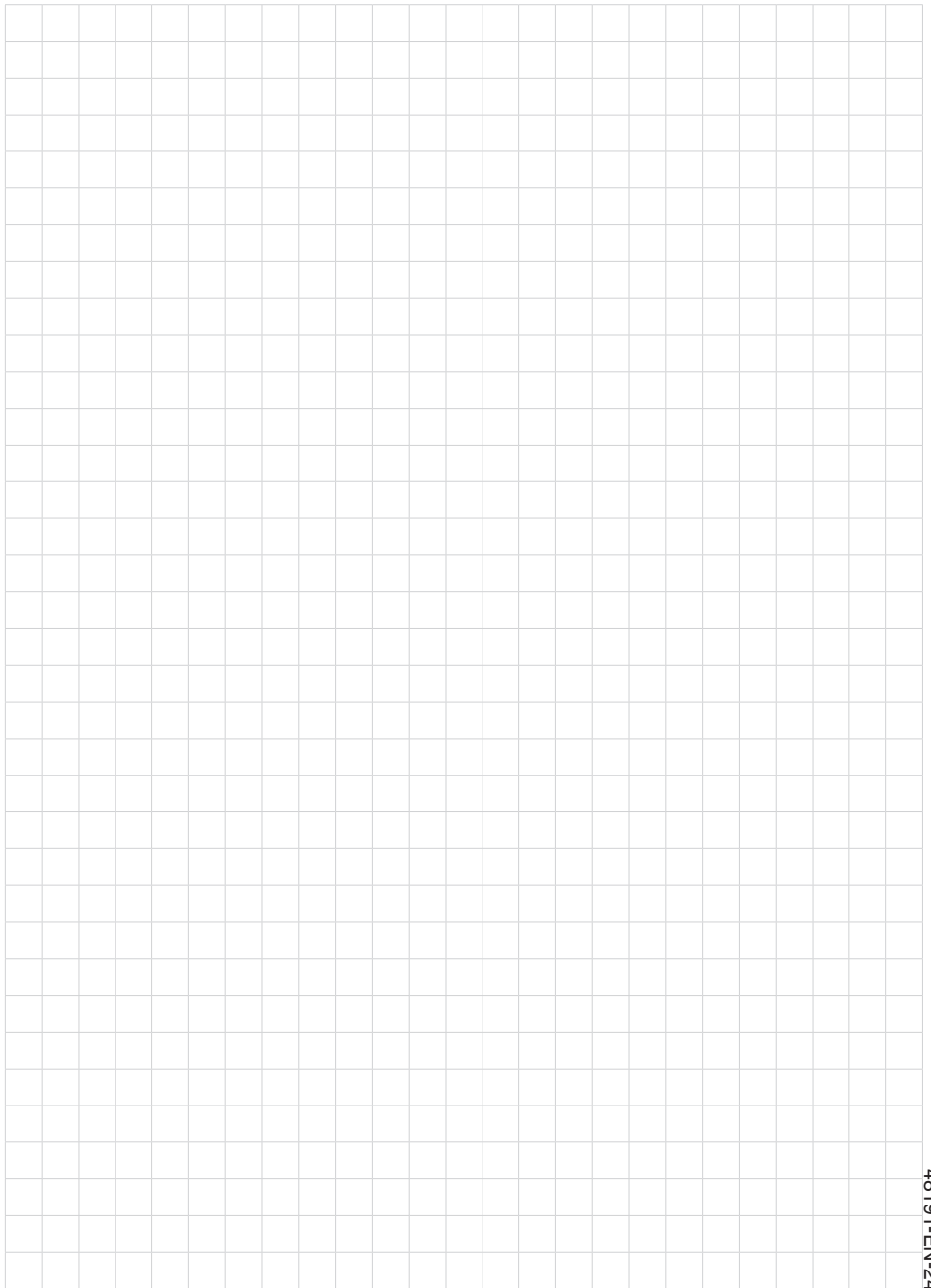

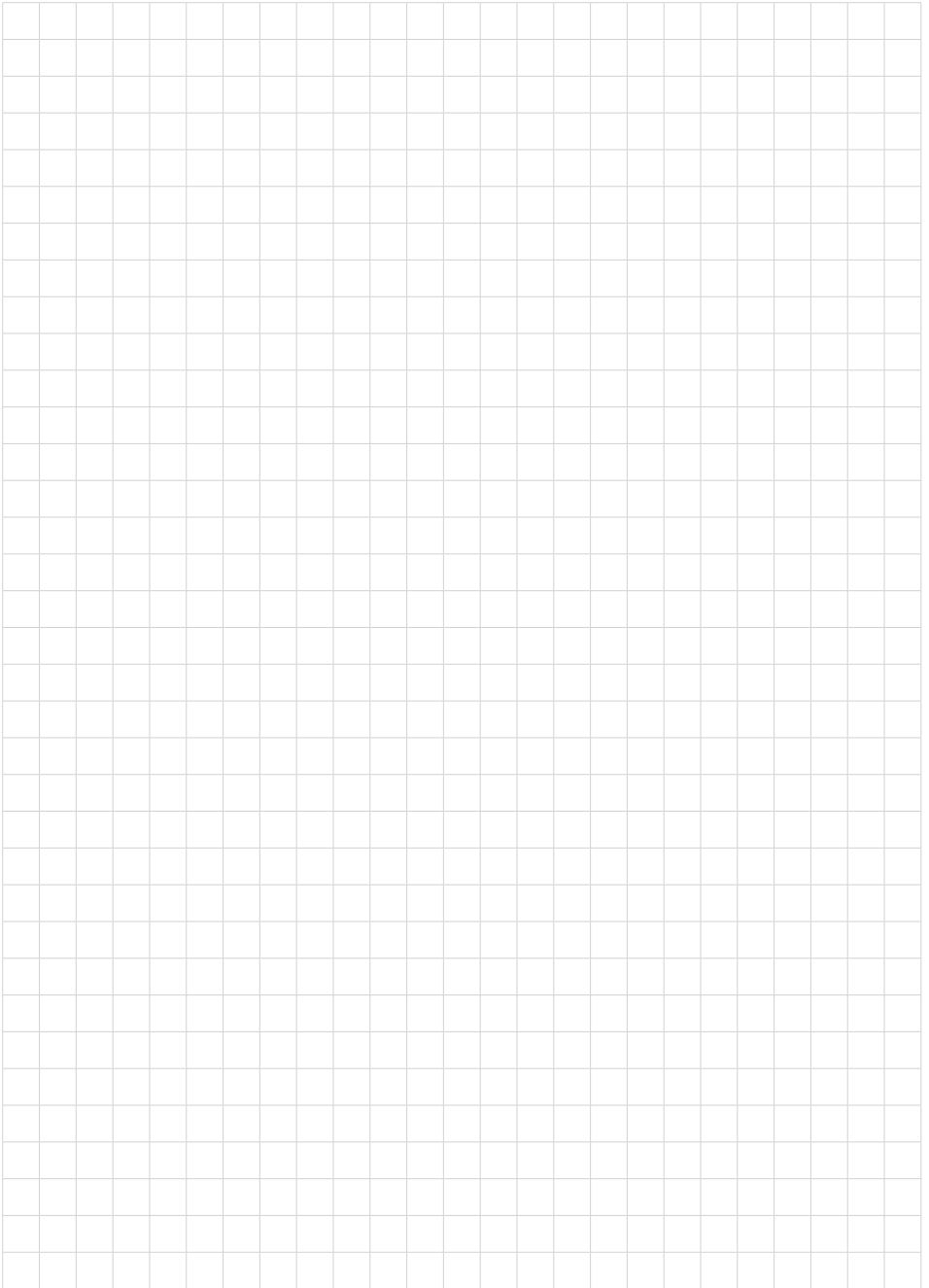

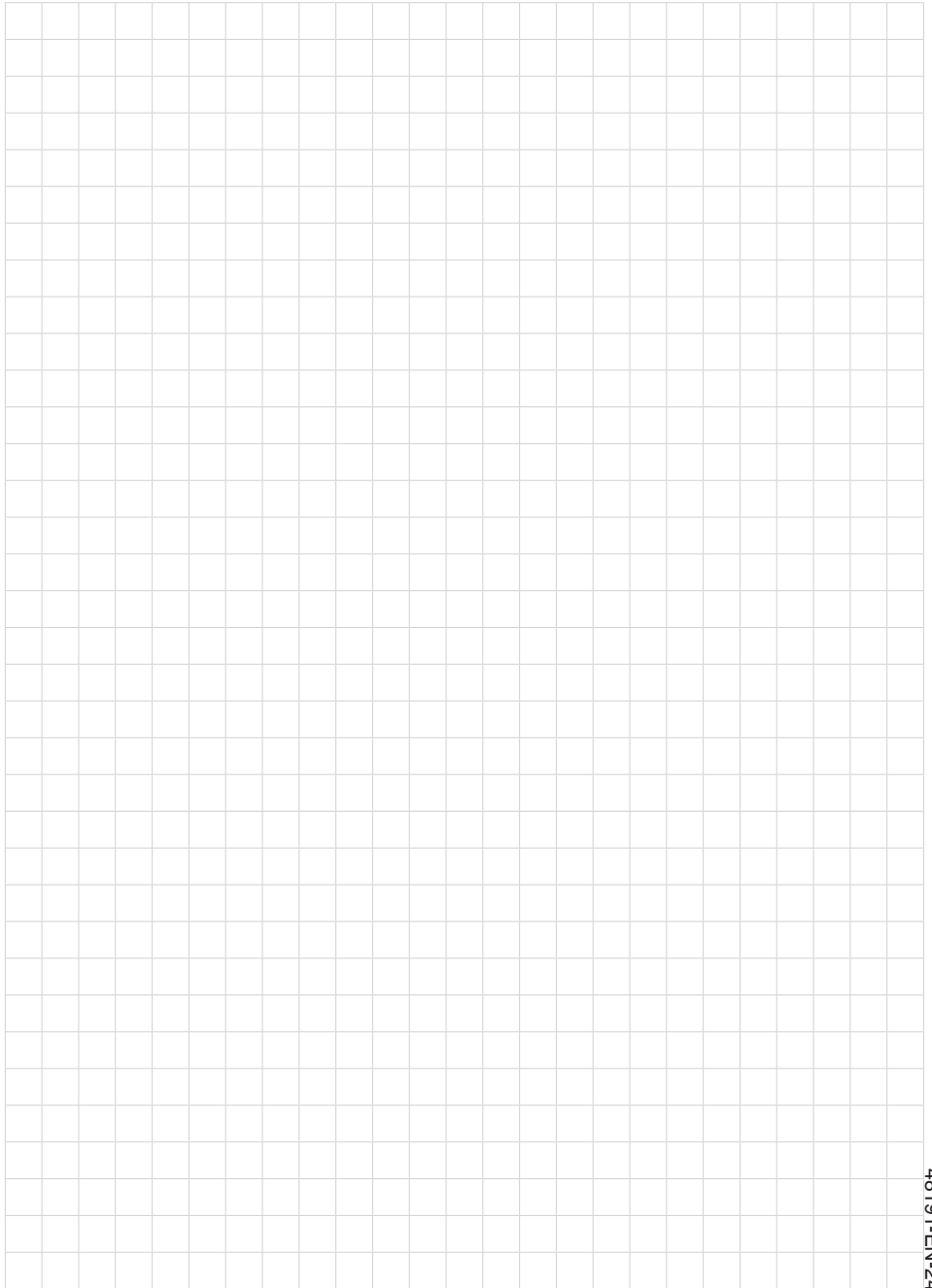

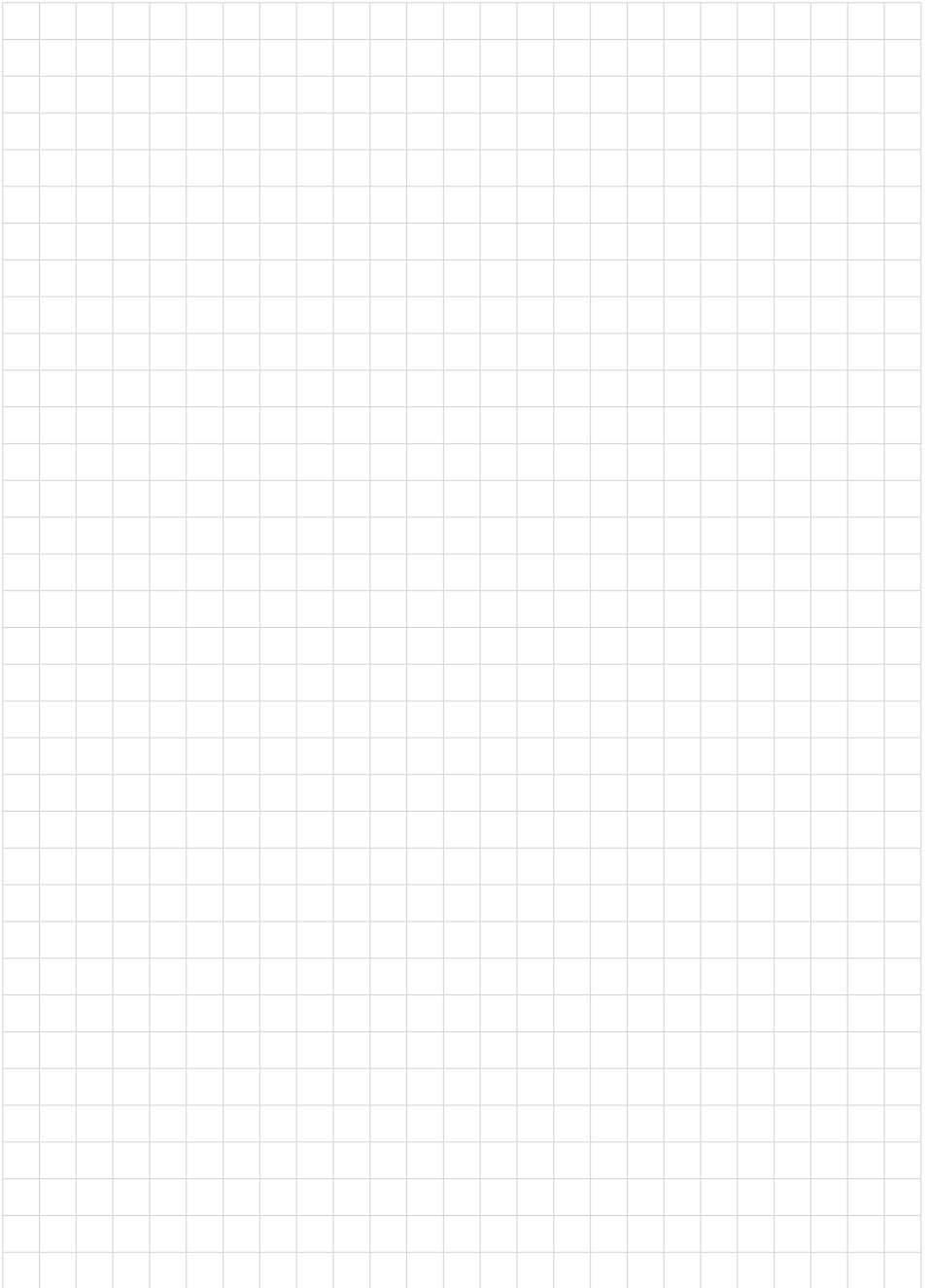

Printing date:

VEGA

All statements concerning scope of delivery, application, practical use and operating conditions of the sensors and processing systems correspond to the information available at the time of printing.

Subject to change without prior notice

© VEGA Grieshaber KG, Schiltach/Germany 2024

48191-EN-240409

VEGA Grieshaber KG
Am Hohenstein 113
77761 Schiltach
Germany

Phone +49 7836 50-0
E-mail: info.de@vega.com
www.vega.com