



Safety instructions

VEGACAL CL6*.DI***H**A

Kosha 13-AV4BO-0754X

Ex d ia IIC T*



CE 0044



Document ID: 48580



VEGA

Contents

1 Area of applicability 3

2 General information 3

3 Technical data 3

4 Application conditions 4

5 Protection against static electricity 5

6 Grounding 5

7 Material resistance 5

8 Pendulum, vibration 5

9 Shortening of the probe cable 6

10 Ignition protection type flameproof enclosure Ex "d" 6

Please note:

These safety instructions are part of the operating instructions:

- 30024 - VEGACAL 62 - 4 ... 20 mA/HART
- 30027 - VEGACAL 63 - 4 ... 20 mA/HART
- 30030 - VEGACAL 64 - 4 ... 20 mA/HART
- 30033 - VEGACAL 65 - 4 ... 20 mA/HART
- 30036 - VEGACAL 66 - 4 ... 20 mA/HART
- 31178 - VEGACAL 69 - 4 ... 20 mA/HART
- 48581 - Certificate Kosha 13-AV4BO-0754X

1 Area of applicability

These safety instructions apply to the capacitive probes of type series VEGACAL CL62/63/64/65/66/69.DI***H**A according to the Kosha 13-AV4BO-0754X (certification number on the type label) and to all instruments with the number of the safety instruction (48580) on the type label.

2 General information

The level measuring instrument VEGACAL CL6*.DI***H**A based on the capacitive measuring principle is used for monitoring or control of levels, also in hazardous areas with combustible liquids, gases, mists or vapours.

The VEGACAL CL6*.DI***H**A are suitable for applications in explosive atmospheres of all combustible materials of explosion groups IIA, IIB and IIC, for applications requiring instruments for use in Zone 0 or 1.

The VEGACAL CL6*.DI***H**A consist of an electronics housing with an "Ex-d" connection compartment and an "Ex-i" connection compartment with integrated electronics module, a process connection element and a sensor. With the VEGACAL CL6*.DI***H**A, there is also the option of mounting the indicating and adjustment module in the "Ex-i" connection compartment.

- The electronics module CL60H is integrated in VEGACAL CL6*.DI***H**A.

The VEGACAL CL62.DI***H**A, VEGACAL CL63.DI***H**A, VEGACAL CL64.DI***H**A and VEGACAL CL69.DI***H**A are provided with rod electrode as sensor, which is also called capacitive electrode. The VEGACAL CL65.DI***H**A and VEGACAL CL66.DI***H**A are provided with a cable electrode as sensor, which is also called capacitive cable electrode.

If the VEGACAL CL6*.DI***H**A are installed and operated in hazardous areas, the general Ex installation regulations IEC 60079-14 as well as these safety instructions must be observed.

The operating instructions as well as the valid Ex mounting regulations and standards for electrical equipment must be observed.

The installation of explosion-protected systems must always be carried out by qualified personnel.

3 Technical data

Electrical data

Non-intrinsically safe circuits

VEGACAL CL6*.DI***H**A

- Power supply and signal circuit: (terminal 1[+], 2[-] in the "Ex-d" connection compartment)

Intrinsically safe circuits

Indicating and adjustment circuit (terminals 5, 6, 7, 8 in "Ex-i" connection compartment or plug connection)

Ignition protection type intrinsic safety Ex ia IIC
For connection to the intrinsically safe circuit of the associated external indicating instrument VEGADIS 61 (IECEx PTB 06.0048).

The rules for the interconnection of intrinsically safe circuits between VEGACAL CL6*.DI*** and the external indication unit VEGADIS 61 are maintained if the total inductance and total capacitance of the connection cable between VEGACAL CL6*.DI*** and the external indication unit VEGADIS 61 of $L_o = 100 \mu\text{H}$ and $C_o = 2.8 \mu\text{F}$ is not exceeded. The indication and adjustment module integrated in VEGACAL CL6*.DI*** and the connected VEGACONNECT are taken into account.

Communication circuit: (I²C-Bus socket in "Ex-i" connection compartment)

Ignition protection type intrinsic safety Ex ia IIC
Only for connection to the intrinsically safe signal circuit of a certified VEGA interface converter VEGACONNECT. The VEGA communication unit VEGACONNECT may only be operated on VEGACAL CL6*.DI***H**A, if there is no explosive atmosphere.

Indicating and adjustment module circuit (spring contacts in the "Ex i" connection compartment)

Ignition protection type intrinsic safety Ex ia IIC
Only for connection to the indicating and adjustment module.

Capacitive measuring circuit: (separate electronics version)

Ignition protection type intrinsic safety Ex ia IIC
For the version with separate housing the length of the triax or coax connection cable between electronics housing and electrode housing (remote housing) may not exceed 10 m.

Due to the not galvanically separated safety barrier integrated in the "Ex-d" connection compartment, the intrinsically safe circuit of VEGACAL CL6*.DI***H**A is connected with ground, potential equalisation due to safety reasons.

4 Application conditions

Permissible ambient temperatures

Zone 0/1 instruments

Temperature class	Permissible ambient temperature on the electronics	Permissible ambient temperature on the sensor
T6	-40 ... +57 °C	-20 ... +60 °C
T5 ... T1	-40 ... +60 °C	-20 ... +60 °C

For applications requiring zone 0/1 instruments, the process pressure of the media must be between 0.8 ... 1.1 bar.

The permissible operating temperatures and pressures without explosive atmosphere are mentioned in the respective manufacturer instructions for each probe type.

Zone 1 instruments

Temperature class	Permissible ambient temperature on the electronics	Permissible ambient temperature on the sensor with PE/PA insulation	Permissible ambient temperature on the sensor without temperature adapter	Permissible ambient temperature on the sensor with temperature adapter
T6	-40 ... +57 °C	-40 ... +80 °C	-50 ... +85 °C	-50 ... +85 °C
T5	-40 ... +60 °C	-40 ... +80 °C	-50 ... +100 °C	-50 ... +100 °C
T4	-40 ... +60 °C	-40 ... +80 °C	-50 ... +135 °C	-50 ... +135 °C
T3, T2, T1	-40 ... +60 °C	-40 ... +80 °C	-50 ... +150 °C	-50 ... +200 °C

If the sensors of the capacitive probes are operated at temperatures higher than those specified in the above table, please make sure by means of appropriate measures that there is no danger of ignition from the hot surfaces. The maximum permissible temperature on the housing must not exceed the values specified in the above table.

The permissible operating temperatures and pressures without explosive atmosphere are mentioned in the respective manufacturer instructions for each probe type.

5 Protection against static electricity

The VEGACAL CL6*.DI***H**A in the version with chargeable plastic parts, such as e.g. metal housing with inspection window ("Ex-i" connection compartment) or sensor insulation, are provided with a caution label referring to the safety instructions that must be followed in case electrostatic charging occurs during operation.



Caution: Plastic parts! Danger of static charge!

- Avoid friction
- No dry cleaning
- Do not mount in areas with flowing, non-conductive products

6 Grounding

In the "Ex-d" connection compartment of the VEGACAL CL6*.DI***H**A in the version with integrated safety barrier "P2-2LH" or "KLEMP2-2LPA/FF", the intrinsically safe circuit must be grounded (with external or internal ground terminal on the housing) due to safety reasons.

The cross section of the earth connection according to IEC 60079-14, paragr.12.2.4 must be taken into account.

7 Material resistance

For applications requiring instruments of zone 0/1 the VEGACAL CL6*.DI***H**A should only be used in media against which the wetted materials are sufficiently resistant.

8 Pendulum, vibration

The sensor of VEGACAL CL6*.DI***H**A has to be effectively secured against swinging or resonating.

9 Shortening of the probe cable

After shortening the probe cable of VEGACAL CL6*.DI***H**A, make sure that the weight is sufficiently secured by means of the threaded pins.

10 Ignition protection type flameproof enclosure Ex "d"

The terminals for connecting to the operating voltage, i.e. signal circuits, are integrated in the connection compartment according to protection type flame-proof enclosure "d".

The gap between housing and cover as well as on the threaded fittings are ignition-proof gaps.

The "Ex-d" connection compartment is provided with a M20 x 1.5 or 1/2-14 NPT thread for connecting to a certified "Conduit" system or for mounting an "Ex-d" cable gland certified according to IEC 60079-1. Cable glands of simple construction may not be used. Please take note of section 13.1 and 13.2 of IEC 60079-1. When connecting to a "Conduit" system, the corresponding seal must be located directly on the "Ex-d" connection compartment.

A certified "Ex-d" cable gland is supplied by default. It is suitable for insertion of armoured or unarmoured cables depending on the ordered version. The instructions in the document accompanying the respective cable gland must be observed. The "Ex-d" cable gland must be screwed tightly into the housing. The supplied cable gland is suitable for the housing temperature range mentioned in the VEGACAL CL6*.DI***H**A specification. If another cable gland is used, the separately certified cable gland or the temperature classes on the electronics determines the maximum permissible ambient temperature on the housing.

Before opening or in case of the lid of the "Ex-d" connection compartment is open (e. g. during connection or service work), make sure that either the supply line is voltage free or no explosive atmosphere is present.

When wiring the connection line to the "Ex-d" connection compartment, it must be sufficiently secured against damage and in conformity with IEC 60079-14.

The connection cables, the cable entries and the plugs or the pipe line sealing facilities must be suitable for the lowest ambient temperature.

The cover of the Exd connection compartment must be screwed in completely before commissioning and secured by screwing out the lid locking screw all the way to the stop.

Unused openings must be sealed according to IEC 60079-1 paragraph 11.9.

Double chamber housing with "Ex-d" connection compartment

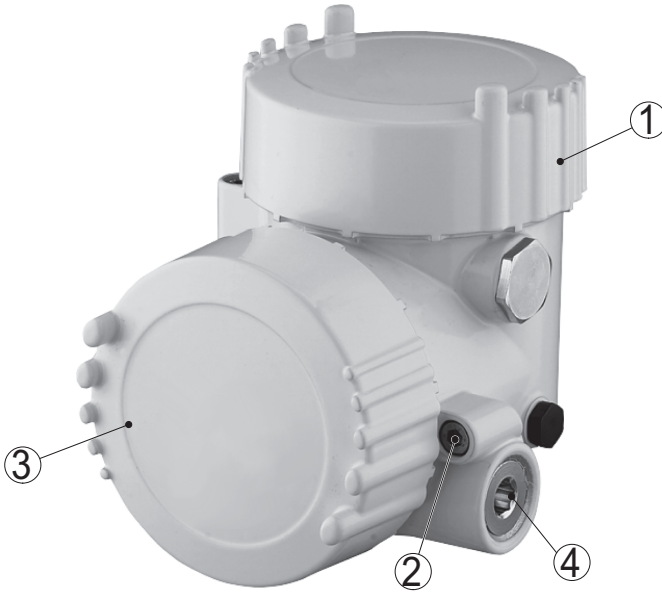

- 1 "Ex-i" connection compartment with electronics module
- 2 Locking screw of the cover
- 3 "Ex d" connection compartment with integrated barrier

The cover of the "Ex-d" connection compartment with "Do not open when an explosive gas atmosphere is present" and the cover of the "Ex-i" connection compartment without caution label must not be exchanged. The covers must be mounted on the corresponding connection compartments.

Printing date:

VEGA

All statements concerning scope of delivery, application, practical use and operating conditions of the sensors and processing systems correspond to the information available at the time of printing.

Subject to change without prior notice

© VEGA Grieshaber KG, Schiltach/Germany 2014



48580-EN-140606

VEGA Grieshaber KG
Am Hohenstein 113
77761 Schiltach
Germany

Phone +49 7836 50-0
Fax +49 7836 50-201
E-mail: info.de@vega.com
www.vega.com